

ANS 21

Version 10-1 EN

Simple solar control unit



Operation
Installation instructions



TECHNISCHE
ALTERNATIVE

Table of contents

Safety requirements	3
Maintenance	3
Solar thermal system	4
Tank load from boiler	4
Selection of the program and sensor type.....	5
Master – slave – function	6
Sensor installation.....	7
Installing the device	8
Electrical connection	8
Tips on troubleshooting.....	9
Technical data.....	10

Safety requirements:



All installation and wiring work on the controller must only be carried out in a zero-volts state.

The opening, connection and commissioning of the device may only be carried out by competent personnel. In so doing, all local security requirements must be adhered to.

The device corresponds to the latest state of the art and fulfils all necessary safety conditions. It may only be used or deployed in accordance with the technical data and the safety conditions and rules listed below. When using the device, the legal and safety regulations apposite to the particular use are also to be observed.

- ▶ The device must only be installed in a dry interior room.
- ▶ It must be possible to isolate the controller from the mains using an all-pole isolating device (plug/socket or double pole isolator).
- ▶ Before starting installation or wiring work, the controller must be completely isolated from the mains voltage and protected against being switched back on. Never interchange the safety extra-low voltage connections (sensor connections) with the 230V connections. Destructive and life-threatening voltages at the device and the connected sensors may occur.
- ▶ Solar thermal systems can become very hot. Consequently there is a risk of burns. Take care when fitting temperature sensors!
- ▶ For safety reasons, the system should only be left in manual mode when testing. In this operating mode, no maximum temperatures or sensor functions are monitored.
- ▶ Safe operation is no longer possible if the controller or connected equipment exhibits visual damage, no longer functions or has been stored for a lengthy period of time under unsuitable conditions. If this is the case, place the controller and equipment out of service and secure against unintentional use.

Maintenance:

If used properly, the system does not require maintenance.

As the components relevant to accuracy are not subjected to loads if used properly, long-term deviation is very low. The unit thus cannot be adjusted.

The construction characteristics of the unit must not be changed for repairs. Spare parts must correspond to the original parts and be used as intended.

Solar thermal system function switch in position S+ (solar)

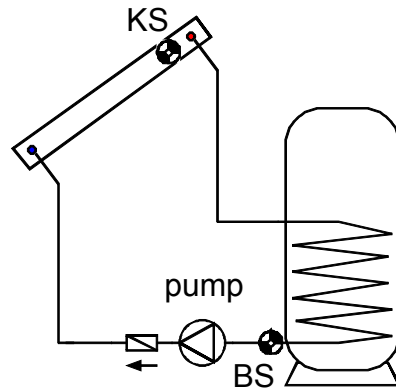

The pump runs when sensor **KS** has a temperature of **diff** higher than sensor **BS** and **BS** has not exceeded the threshold **max**.

$$\text{Pump} = \text{KS} > (\text{BS} + \text{diff}) \ \& \ \text{BS} < \text{max}$$

Collector excess temperature: if the collector temperature climbs above 130°C, the pump is switched off and only released again, if the temperature falls below 110°C. During the excess temperature shutoff, the two top LEDs of the collector display flash.

Tank load from boiler function switch on position L+ (feed pump)

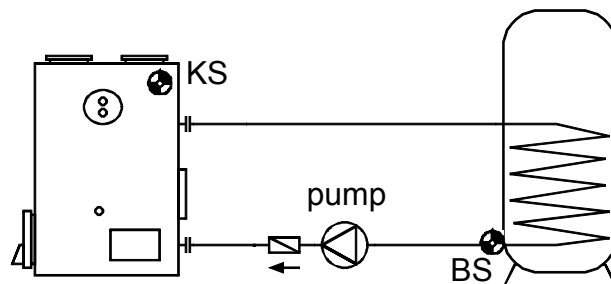

The pump runs when **sensor KS** is greater than the threshold **max** (here used as "min") and **sensor KS** is greater than **BS** by the difference **diff**.

$$\text{Pump} = \text{KS} > \text{max} \ \& \ \text{KS} > (\text{BS} + \text{diff})$$

The difference function:

The output only switches the pump when the temperature of the collector or the boiler is greater than the temperature of the boiler by the set difference **diff**.

The thermostat function:

Solar S: If the **tank temperature** exceeds the set **maximum threshold**, the pump is switched off regardless of the temperature of the collector (protection from calcification).

Feed pump L: If the **boiler temperature** falls below the minimum threshold, the pump is switched off (protection from sooting).

Selection of the program and sensor type:

The selection of the program and the sensor type has to be made before installation.
The controller does not operate or operates incorrectly, if the incorrect sensor type is set.

ALWAYS PULL THE MAINS PLUG BEFORE OPENING THE CASING!

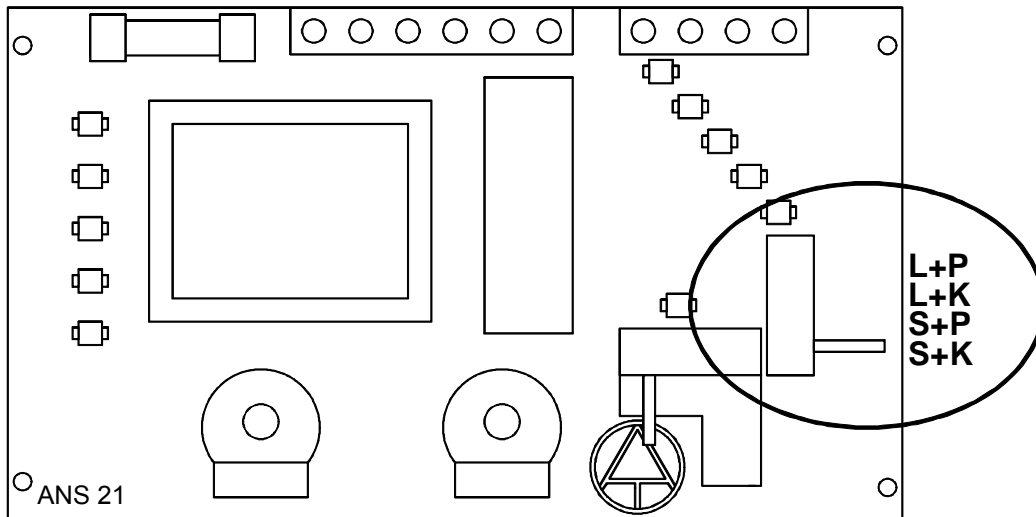

The selection occurs by means of a slide switch on the right border of the board. There is no access possible to the slide switch from outside.

Four positions are available:

- 1) **L+P** Feed pump requirement by PT1000 sensors
- 2) **L+K** Feed pump requirement by KTY sensors
- 3) **S+P** Solar power system with PT1000 sensors
- 4) **S+K** Solar power system with KTY sensors

Manual / automatic switchover:

On the front side of the control is a sliding switch with the functions AUS (=OFF), AUT (= automatic, normal setting) and HAND (=ON, endurance run).

Master – slave – function:

Two ANS 21 controllers, can be connected via the data link. Consequently it is possible to charge two tanks, of which one tank is prioritised for charging by the "master".

Both sensors are connected to the master.

Only the tank sensor BS is connected to the slave controller that is subordinate to the master. The slave receives the collector temperature from the master.

There are two operating modes for this master-slave operation:

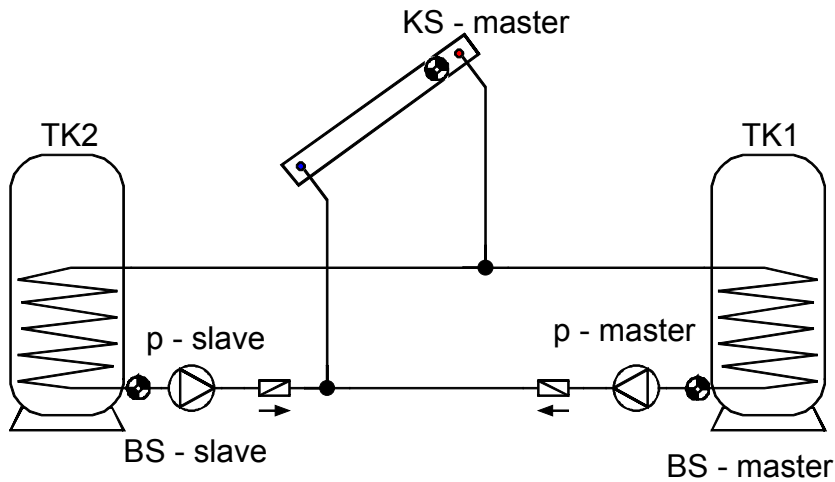

- 2-pump mode:** as can be seen in the schematic diagram, a pump is connected to both master and slave. The master pump has absolute priority, hence the slave pump can only be switched on if the master pump is switched off (dependent on the starting conditions). 2-pump mode is activated if the terminals of the collector sensor at the slave remain disconnected (= interruption).

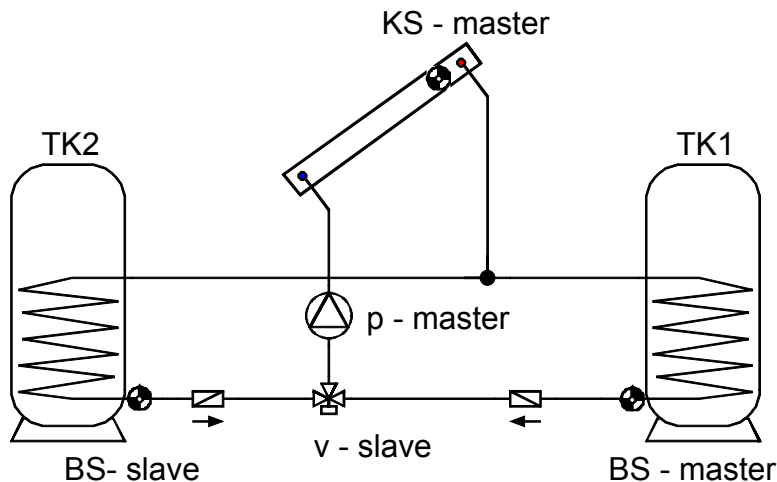

- Pump-valve mode:** the common pump is connected to the master controller, the slave controls the valve. As soon as the starting condition is no longer fulfilled at the master, the slave receives the command to switch on the pump and switches the valve to "its" consumer TK2. Pump-valve mode is activated if the terminals of the collector sensor at the slave are bridged with a jumper (= short circuit).

Sensor installation:

The sensors must be properly arranged and installed for the system to function correctly.

- **Collector sensor (red cable):** Either insert the sensor in a pipe directly soldered or riveted to the absorber and extending out of the collector casing or screw the sensor onto a T piece on the end of the supply line's collecting tube using an immersion sleeve. No water may be allowed to enter the immersion sleeve (danger of freezing).
- **Storage sensor:** The sensor should be used with an immersion sleeve just above the outlet for the exchanger's return line if heat exchangers with ribbed tubes are used and with a T piece on the outlet of the exchanger's feed line if integrated non-ribbed tubes are used. It should not be installed below the respective register or heat exchanger in any case.
- **Boiler sensor (boiler supply line):** This sensor is either screwed into the boiler using an immersion sleeve or at a short distance from the boiler on the supply line.
- **Pool sensor (swimming pool):** Install directly at the outlet from the pool on the suction line as an attached sensor (see attached sensor). Installation using an immersion sleeve is not recommended due to the possibility of condensation within the sleeve.
- **Attached sensor:** Attach to the line using pipe or hose clamps. Make sure the material used is proper (corrosion, temperature resistance, etc.). Then, the sensor has to be well insulated so that the pipe temperature is measured exactly and the ambient temperature does not influence the measurement.

All of the sensor cables with a cross-section of 0.75mm^2 can be extended up to 30m. Beyond 30m they can be extended by use of a suitably larger cross section. The sensor and the extension can be connected as follows: cut the heat-shrinkable sleeve provided down to 4 cm and put it over a wire; twist the naked ends of the wires, and put the heat-shrinkable sleeve over the naked end; heat it carefully (such as with a cigarette lighter) until the sleeve has wrapped itself around the connection.

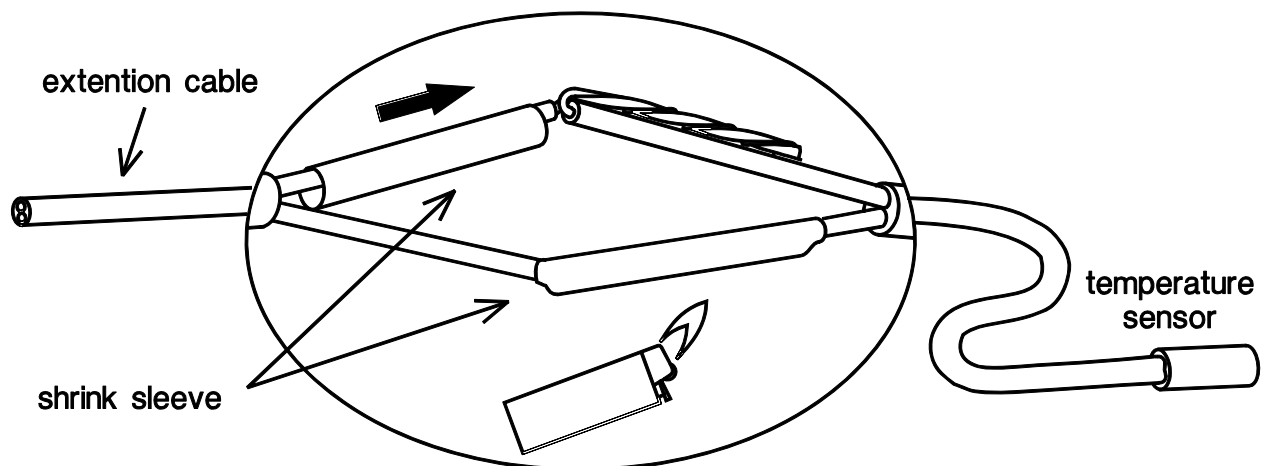

Installing the device

WARNING! ALWAYS PULL THE MAINS PLUG BEFORE OPENING THE CASING!

Unscrew the four screws on the edges of the case and screw on the basin through the two holes on the bottom side using the fastening screws provided.

Electrical connection

Only a trained electrician may provide the electrical connection in compliance with local guidelines. The sensor lines must not be laid in the same cable channel as the supply voltage. In a commonly used cable channel, appropriate shielding has to be provided.

Caution: Only work on the inside of the control system when it is dead. The connections are to be put according to the marking of the clamps.

Note: To provide protection from lightning, the system has to be grounded in accordance with the regulations. Sensor failures due to storms and static electricity are usually the result of improper grounding or overvoltage protection on the collector sensor.

Pin configuration:

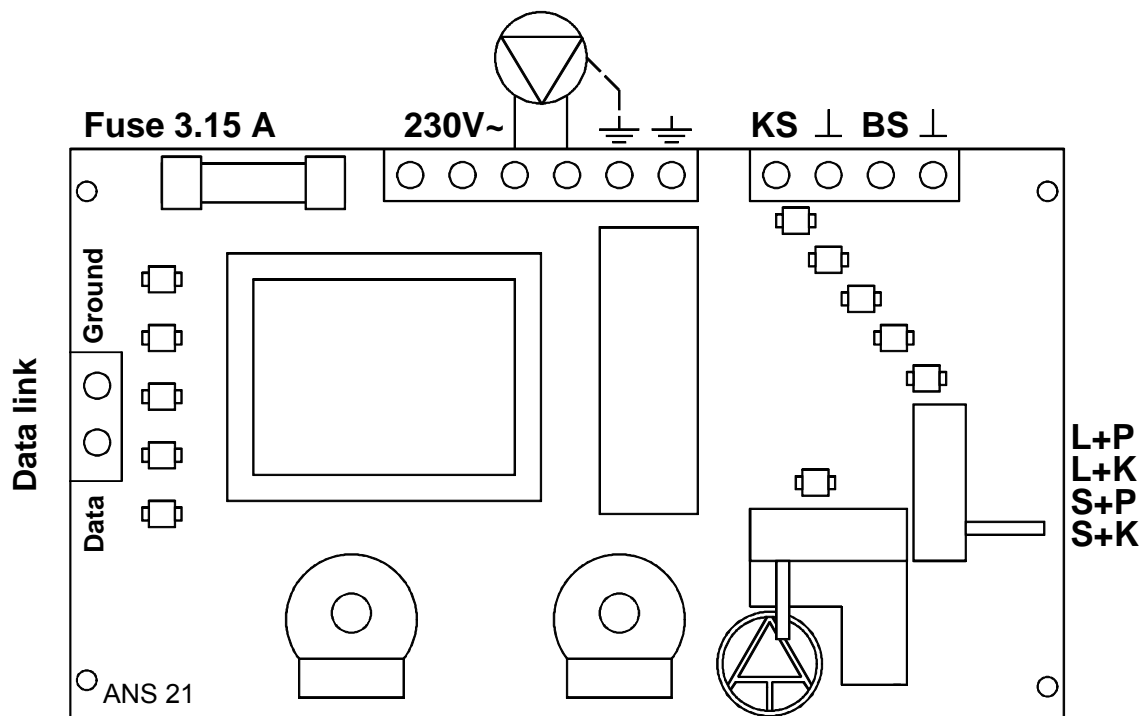

When using the master-slave function, the data link must be connected in-phase to both units (data to data, ground to ground).

Tips on troubleshooting:

When the control system does not function properly on automatic mode, the function switch and the sensors should be checked.

Version display: as the controller is connected, the version is temporarily displayed using the right tank LEDs (binary code - reading from the top down).

A short-circuit or an interruption of a sensor are displayed directly on the control system. If a short-circuit occurs, the lowest LED of the collector or tank icon blinks. In case of an interruption, the top LED of the icon blinks.

Collector excess temperature: if the collector temperature climbs above 130°C, the pump is switched off and only released again, if the temperature falls below 110°C.

During the excess temperature shutoff, the two top LED's of the collector display flash.

Master-slave mode: the control circuit continues to function at least partly, if an error occurs at a sensor:

- if the master tank sensor fails, the master pump is deactivated, however it can activate the slave at any time, depending on the operating mode.
- if the slave tank sensor fails, the master operates in stand-alone mode (master-slave mode is deactivated)
- if the master collector sensor fails, the system shuts down completely (LEDs continue to display the error)

In addition, the sensors can be measured by means of an ohmmeter.

Temp. [°C]	0	10	20	25	30	40	50	60	70	80	90	100
R (Pt1000) [Ω]	1000	1039	1078	1097	1117	1155	1194	1232	1271	1309	1347	1385
R (KTY) [Ω]	1630	1772	1922	2000	2080	2245	2417	2597	2785	2980	3182	3392

If the system is not in operation although supply voltage is connected, the 3.15A quick-blowing fuse that protects the control system and the output should be checked and exchanged if necessary.

Technical data:

Temp.difference:	adjustable from 2-12°C (hysteresis = 3K)
Overheating temp./ Min.threshold:	adjustable from 40-100°C (hysteresis = 3K)
Accuracy:	tip. +-2%
Output:	230V~/ max. 200VA
Power draw:	max. 2 W
Supply cable:	3x 1mm ² H05VV-F conforming to EN 60730-1

Dimensions in mm:

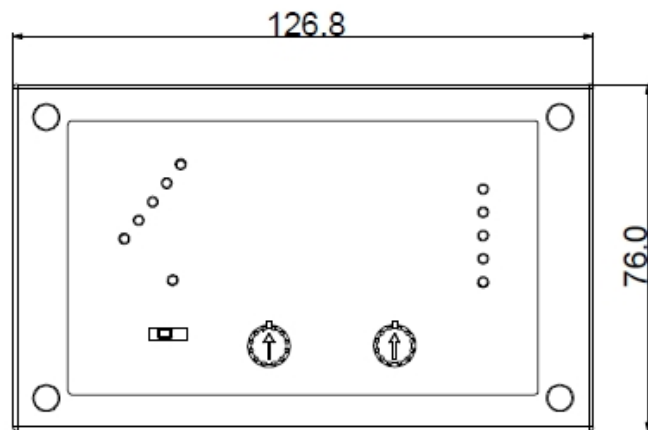
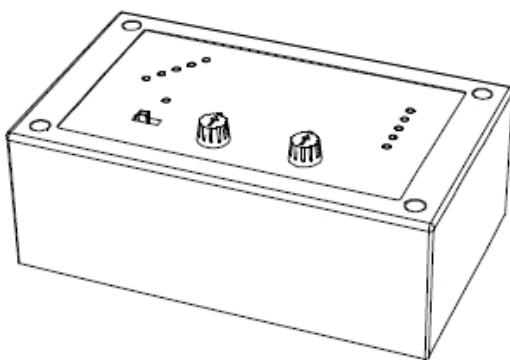
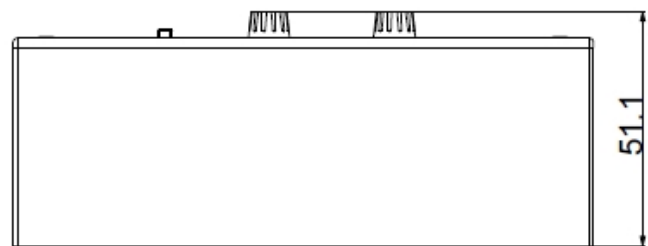
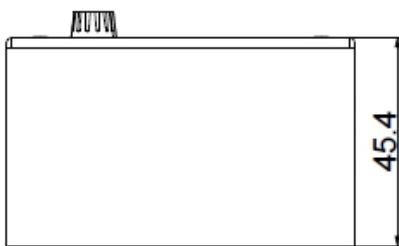

We reserve the right to make technical changes.

© 2011



TECHNISCHE ALTERNATIVE

ELEKTRONISCHE STEUERUNGSGERÄTEGESELLSCHAFT M. B. H.
A-3872 Amaliendorf, Langestraße 124

EC- DECLARATION OF CONFORMITY

Document- Nr.: / Date TA10007 / 23.08.2010
Company / Manufacturer: Technische Alternative
elektronische SteuerungsgerätegesmbH.
Address: A- 3872 Amaliendorf, Langestraße 124
Product: ANS 21
The stated above product complies with the following essential requirements:
EU requirements: 2006/95/EG *Low voltage standard*
2004/108/EG *Electromagnetic compatibility*

Employed standards:

EN 60730-1:2009 08 01 Automatic electrical controls for household and similar use -
Part 1: General requirements
EN 61000-6-3:2007 11 01 Electromagnetic compatibility (EMC) - Part 6-3: Generic
standards - Emission standard for residential, commercial
and light-industrial environments
EN 61000-6-2:2006 05 01 Electromagnetic compatibility (EMC) - Part 6-2: Generic
standards - Immunity for industrial environments
Position of CE - label: On packaging, manual and type label



Issuer: Technische Alternative
elektronische SteuerungsgerätegesmbH.
A- 3872 Amaliendorf, Langestraße 124

This declaration is submitted by:

General management

This declaration certifies the agreement with the named standards, contains however
no warranty of characteristics.
The security advices of included product documents are to be considered.

UIDNr.: ATU 17986204, Firmenbuch-Nr.: FN37578m, DVR-Nr.:1011553, ARA-Lizenz-Nr.:1996

Telefon ++43(0)2862/53635 Fax ++43(0)2862/53635-7 E-mail: mail@ta.co.at <http://www.ta.co.at>

Guarantee conditions

Note: The following guarantee conditions do not in any way limit the legal right to a guarantee, rather expand your rights as a consumer.

1. The company Technische Alternative elektronische Steuerungsgerätegesellschaft m. b. H. provides a two-year guarantee from the date of purchase by the end consumer for all the devices and parts which it sells. Defects must be reported immediately upon detection and within the guarantee period. Technical support knows the correct solution for nearly all problems. In this respect, contacting us immediately will help to avoid unnecessary expense or effort in troubleshooting.
2. The guarantee includes the free of charge repair (but not the cost of on site fault-finding, removal, refitting and shipping) of operational and material defects which impair operation. In the event that a repair is not, for reasons of cost, worthwhile according to the assessment of Technische Alternative, the goods will be replaced.
3. Not included is damage resulting from the effects of overvoltage or abnormal ambient conditions. Likewise, no guarantee liability can be accepted if the device defect is due to: transport damage for which we are not responsible, incorrect installation and assembly, incorrect use, non-observance of operating and installation instructions or incorrect maintenance.
4. The guarantee claim will expire if repairs or actions are carried out by persons who are not authorised to do so or have not been so authorised by us or if our devices are operated with spare, supplementary or accessory parts which are not considered to be original parts.
5. The defective parts must be sent to our factory with an enclosed copy of the proof of purchase and a precise description of the defect. A filled in "service advice note", which can be downloaded from our homepage www.ta.co.at, will accelerate processing. A prior clarification of the defect with our technical support is necessary.
6. Services provided under guarantee result neither in an extension of the guarantee period nor in a resetting of the guarantee period. The guarantee period for fitted parts ends with the guarantee period of the whole device.
7. Extended or other claims, especially those for compensation for damage other than to the device itself are, insofar as a liability is not legally required, excluded.

TECHNISCHE ALTERNATIVE

elektronische Steuerungsgerätegesellschaft m. b. H.

A-3872 Amaliendorf Langestraße 124

Tel ++43 (0)2862 53635

Fax ++43 (0)2862 53635 7

E-Mail: mail@ta.co.at

--- www.ta.co.at ---



© 2011