



BL-NET Bootloader and MD-GSM



Together with the software provided, this versatile device currently offers the following basic functions:

- ◆ Backup and restore of functional data (configuration) to/from a PC (data upload and download)
- ◆ Update of the operating system from devices connected to the CAN bus and update of the Bootloader itself using the software provided on the homepage at www.ta.co.at
- ◆ Data logging of the temperature and output statuses of all UVR controllers and various other measurements, such as rotational speed or power via DL bus or CAN bus
- ◆ Direct access via Ethernet from a PC to devices in a CAN network

Available interfaces:

- ◆ CAN bus for direct communication with a UVR1611 system
- ◆ CAN infrared interface for quick and easy data backup
- ◆ Two data line inputs for recording measured values from up to two controllers
- ◆ USB interface for PC communication (via virtual COM port)
- ◆ Ethernet interface for communication over LAN networks
- ◆ GSM module (optional) for communication via SMS

Table of contents

Hardware / General Information	5
Power supply	5
DL bus	5
CAN bus and IR-CAN infrared interface	6
USB	7
Ethernet/LAN	7
GSM module (optional)	8
Software	8
Installation	8
Deinstallation	8
USB driver	9
Installation	9
Configuring the virtual COM port	10
Winsol (from version 1.21)	11
SETUP	11
Selection of the data logging process	12
Data frame configuration	12
Connection type selection	13
Save criterion	15
Display	16
Names	17
Receive	17
Graphic	19
Excel	21
Customer mode	22
Troubleshooting	24
Memory Manager (from version 2.07)	27
Transfer of controller data	29
Functional data upload (PC→Bootloader)	29
Functional data download (Bootloader→PC)	30
Operating system upload (PC→Bootloader)	31
Transfer of Bootloader data	32
Troubleshooting	33
Connecting the BL-NET to a LAN network	34
Accessing the BL-NET via a browser	38
Accessing « Hauptmenue » (main menu) page	38
Changing " Passwörter " (passwords)	39
Operating levels	39
" CAN-Netzwerk " (CAN network)	41
UVR1611 menu page	41
Example: Parameterising input 1	42
BL-NET " Datenverwaltung " (data administration)	43
" GSM-Einstellungen " (GSM settings) in „ Hauptmenue “ (main menu)	44
" Telefonnummern " (telephone numbers)	45
" Abfragen " (queries) and " Meldungen " (messages) (analogue/digital)	45
" Abfragen Gruppen " (group queries)	47
" Befehle " (commands) (analogue/digital)	48
" Ethernet – Konfiguration " (Ethernet configuration)	50
Data transfer BL-NET ⇔ UVR1611	51

Selection of the interface for the data transfer	51
CAN bus line.....	51
Infrared interface.....	51
NODE 63:.....	51
Data transfer procedure	51
Functional data download (BL ⇒ UVR1611)	52
Operating system download (BL ⇒ UVR1611).....	53
Data transfer via Ethernet using a browser	54
Troubleshooting data transfers	54
" Online-Schema " (online scheme).....	55
Creating a graphic for the online scheme.....	55
Creating the HTML file	55
Factory settings	57

Hardware / General Information

Power supply

Power is provided via a connection between the controller and Bootloader over a DL (Data Line) or CAN cable. Data retention is guaranteed, even without a power supply. A compartment for an industry-standard 9V battery is provided, allowing it to be used as a portable device without a cable connection to the controller. Alkaline batteries are recommended. They have a lower self-discharge and live four times longer than normal batteries. This allows an infrared-(IR)-CAN interface to a controller and a USB connection to a PC. After the data transfer, the device switches off automatically. This ensures years of use. When operating the **Ethernet** interface or the **GSM module**, power must **always** be provided via the **CAN bus**.

Active interfaces	USB	Ethernet	IR-CAN	Module (GSM)
Power supply				
Data line	X			
CAN bus	X	X		X
Battery	X		X	

If the Bootloader is used as a hand device without a cable connection to a controller, it is advisable to remove the BL-NET from the PC after a successful data transfer to avoid unwanted activation of the Bootloader from the PC and ensure long battery life.

DL bus

Every UVR controller has a data line output DL (with the EEG30, TFM66 ⇒ D0) that, together with the (sensor) ground conductor, forms a two-conductor cable (DL bus). The BL-NET has 2 data line (DL) inputs for simultaneously recording measured values from up to two controllers.

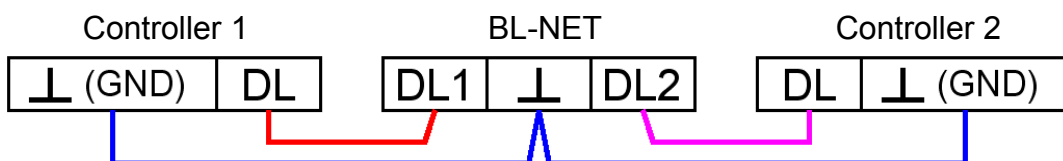

Any desired cable for the DL bus with a minimum cross-section of 0.35 mm² can be used as a data line cable (e.g. twisted pair), over a maximum distance of 30 m. If the data from two controllers is to be acquired by the Bootloader, then separate shielded cables must be used to provide protection against crosstalk errors. The data conductors must never be in the same cable as the CAN bus.

If only the data line cable (DL-bus) is connected to the BL-NET, then this is also used as the power supply for the Bootloader (bus load = 52%).

When the DL is connected, the Bootloader indicates that a device has been connected to the DL input by briefly flashing the green LED. The Bootloader automatically recognises the number and type of the connected controller(s).

NOTE:

- ◆ With the UVR1611 controller, output 14 (DL) can be used as both a data connection and a control connection. For data logging via DL-bus, output 14 must therefore always be configured as a "Data Line" via the "Outputs" menu.
- ◆ UVR1611 - controllers from version A2.16 additionally enable the recording of network input variables, which are handled by the bootloader as a virtual second UVR1611. When parameterizing output 14 as a "Data link", the menu option *NETW.EG.=>DL.:* must be answered by *yes*. Logging of network variables is thus not possible when two physical controllers are connected to the Bootloader (this instruction only applies for data logging via the DL bus).
- ◆ Only the UVR1611 and UVR61-3 devices can supply enough power for the Bootloader via the data line. Simultaneous power supply to a Bootloader and external sensors is not possible. In this case, the Bootloader must be supplied via a power pack (CAN-NT).
- ◆ An optional power adaptor (CAN-NT) is available for other devices.
- ◆ Logged data is lost when the number of data connections (DL-bus) or the controller type is changed!
- ◆ If power is removed from the Bootloader then, at most, only data from the last hour is lost.

CAN bus and IR-CAN infrared interface

The IR-CAN interface (infrared CAN) offers a simple way of transferring functional data. It is located under the two buttons of the UVR1611 and on the lower side of the Bootloader case. During the data transfer, the Bootloader must lie in the correct position on the controller: Bootloader – upper edge = Controller display – lower edge, the sideways position of the display is marked on the Bootloader.

For transferring the functional data the controller must be prepared via the "**Data Administration**" menu. This is only permitted in expert mode. The controller switches to data transfer mode when the "*Upload resp. Download data really start?*" query is confirmed. After this, the Bootloader is placed in the correct position on the controller (at the lower edge of the display and between the markings). As with the CAN cable, the data transfer is started by pressing the START button on the Bootloader. The green LED flashes during the transfer and the functional data takes about 15 seconds to transfer.

Since an operating system can take about 5 minutes to transfer, this should always be done via a CAN bus cable connection. If the loading of the operating system is interrupted then a renewed transfer is only possible via a cable connection!

In addition to data transfer, the Ethernet interface of the CAN bus also allows direct access to the CAN network devices via a browser on the PC. Both LEDs flash briefly when the CAN cable is plugged in and after about 20 seconds, the green LED lights up to indicate that the BL-NET is ready to operate on the CAN bus.

When using the CAN bus to connect several devices with a total cable length above 5 m, correct termination of the bus is important. The network **terminators** must be connected at the **cable ends**. The lower side of every controller, and the Bootloader (alongside the start button), have a corresponding jumper bridge (*term*) for this. A CAN bus must never be connected from a node (terminal) to other devices in a star formation. The correct layout is a series cable from the first device (with terminator) to the second device, then the third, etc., and the last bus connection must also have a termination jumper.

Additional information on the correct layout of a CAN bus network (e.g.: cable selection, etc.) is provided in the UVR1611 controller handbook.

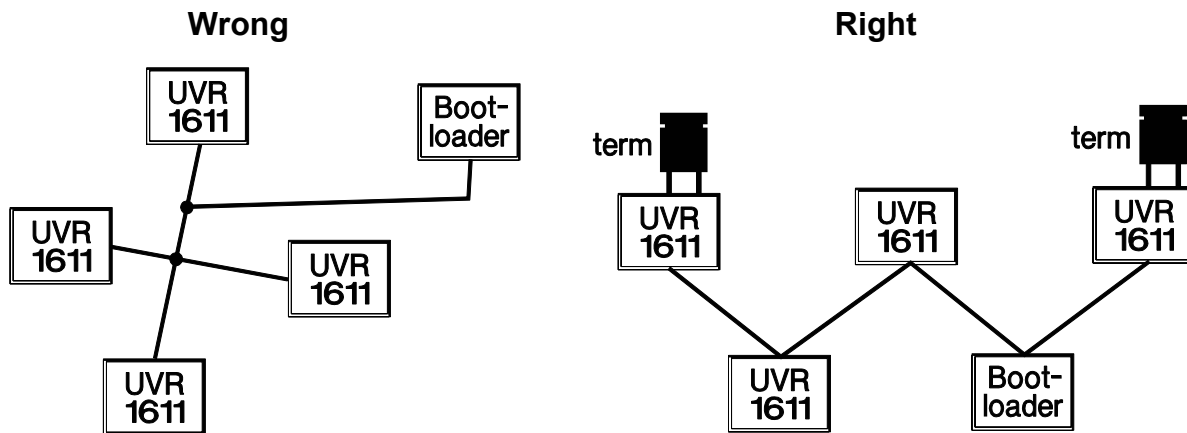

USB

The USB interface does **not** represent an electrical connection between the Bootloader and PC. For reasons of safety, it is electrically isolated via optocouplers. The Bootloader thus requires its own power supply, via the DL, CAN or a battery, when communicating via USB.

For communication between the PC and BL-NET via USB, a special driver is also required that creates a virtual COM interface in Windows, which is then used by the *Winsol* or *Memory Manager* programs to access the Bootloader. **See also the section "USB driver".**

Ethernet/LAN

The Ethernet interface is only active when a CAN connection is present. When operating with only a data cable (DL-bus) or a battery, Ethernet communication is not possible.

A **crossed** network cable ("Cross-over") must be used for direct connection with a PC. The PC must also be assigned a fixed IP address. The rear side of the BL-NET (the oval window) has a green LED that indicates an Ethernet connection to another device, and a red LED that indicates data transfer.

The Bootloader requires a fixed IP address because it does not support DHCP. **See also the section "Connecting the BL-NET to a LAN network".**

GSM module (optional)

An optional GSM module is available for the BL-NET. This can be retrofitted by plugging it into a male socket inside the Bootloader.

The SIM card PIN query must always be deactivated for operation! This can be done using a mobile phone.

Before commissioning the BL-NET with a GSM module, the SIM card must be inserted into the correct socket and the antenna must be connected. **The GSM module is only activated when the CAN bus is connected.** The red LED lights up after the module has successfully initialised. An error is indicated by a flashing red LED. If this flashing occurs for longer than five minutes, then initialisation has failed and all connections must be checked.

The GSM module is configured via the browser. These settings are described in the section "**Accessing the BL-NET via a browser**".

Software

Installation

The software on the CD provided (*Winsol*, *Memory Manager*, etc.) can be installed by selecting the desired menu option from the autostart menu that is automatically displayed when the CD is inserted.

The latest versions of the software are available for downloading at <http://www.ta.co.at> and they overwrite the existing software without losing any previously stored data. However, it is recommended to deinstall the existing versions of the software before installing new versions. This only then removes the application and all data created with the application is retained.

CAUTION! Newer software versions are not always compatible with the version of the Bootloader operating system. The homepage provides information on this. It may be necessary to also upgrade the Bootloader operating system (see "*Memory Manager*").

Deinstallation

The programs can be deinstalled using the <add/remove programs> function in the Windows control panel.

Windows 98, ME, 2000, XP: ... ⇒ Control Panel ⇒ Software (add or remove programs)

Windows Vista, 7: ... ⇒ Control Panel ⇒ Programs and Functions

USB driver

The USB driver is required for USB communication between the PC and the Bootloader and it creates a virtual COM port on the PC for this purpose.

The driver must be installed on the PC for this (see "**Installation**") and is automatically loaded when a Bootloader is connected to the PC.

The required drivers are contained in the attached CD-ROM in the folder <install\USB-Treiber>, can be downloaded from the homepage <http://www.ta.co.at> or can also be installed via Windows Update.

Installation

When a Bootloader or D-LOGG_{USB} is connected to the PC with a USB cable, the PC automatically recognises a new hardware component and automatically starts the "Hardware-Assistant" (Hardware Wizard) if a driver has not yet been installed for this device.

If an Internet connection is available, Windows connects automatically to the Windows Update website to install a suitable driver. In this case no further steps are necessary.

If an Internet connection is not available, or no suitable driver has been found or if Windows is configured to prevent the automatic installation of drivers, the required drivers can be manually installed.

If the Wizard does not start automatically, the installation can also be manually started. When the device is connected to the PC but the driver has not been installed, it is displayed in the Windows **device Manager**) with an exclamation mark in one of the <other devices>, <Ports (COM and LPT)> or <USB Controller> lists. The driver installation can be manually started from here.

You can find more information in the USB drivers manual in the attached CD-ROM or under <http://www.ta.co.at>.

Configuring the virtual COM port

If the virtual COM port assigned to the driver on installation is not supported by the *Winsol* and *Memory Manager* programs, the driver can be manually assigned a different free port. For a PC with an internal modem, it should be noted that COM3 is usually used for this modem.

The Bootloader must be connected to the PC in order to configure the virtual COM port in the Windows **"Geräte-Manager" (device manager)**.

Windows 98:

Start ⇒ "Einstellungen" (settings) ⇒ "Systemsteuerung" (control panel) ⇒ System ⇒ "Geräte-Manager" (device manager) ⇒ "Anschlüsse" (ports) (COM and LPT)

Windows 2000, XP (classic view):

Start ⇒ "Einstellungen" (settings) ⇒ "Systemsteuerung" (control panel) ⇒ System ⇒ Hardware ⇒ "Geräte-Manager" (device manager) ⇒ "Anschlüsse" (ports) (COM and LPT)

Windows Vista (classic view):

Start ⇒ "Einstellungen" (settings) ⇒ "Systemsteuerung" (control panel) ⇒ "Geräte-Manager" (device manager) ⇒ "Anschlüsse" (ports) (COM & LPT)

Windows 7:

Start ⇒ "Systemsteuerung" (control panel) ⇒ Hardware und Sound ⇒ „Geräte-Manager“ (device manager) ⇒ "Anschlüsse" (ports) (COM&LPT)

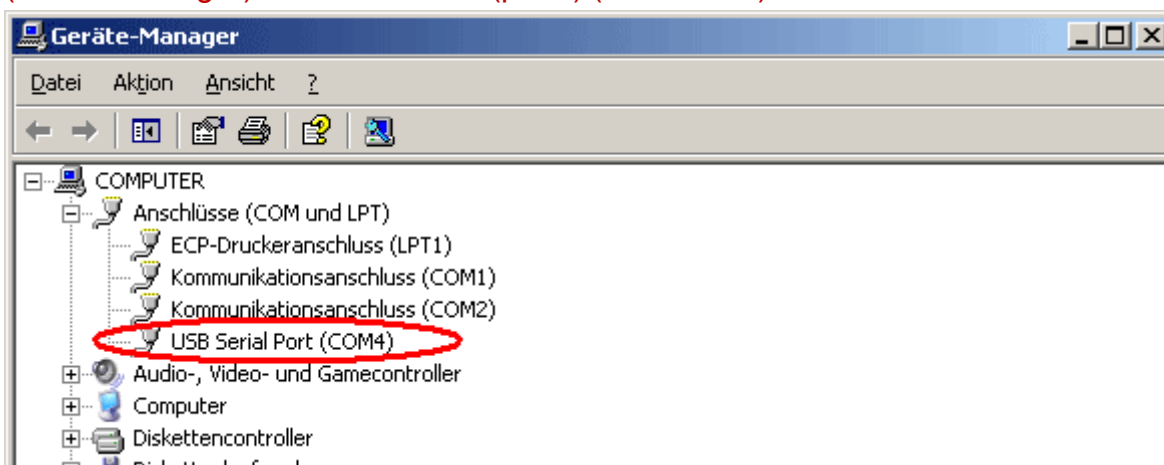

The driver can be assigned a different COM port in the properties of the <USB Serial Port>:
USB Serial Port ⇒ Properties ⇒ Port Settings ⇒ Advanced...

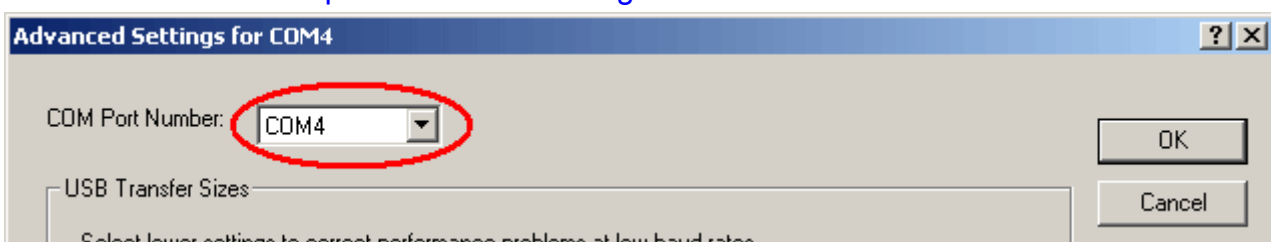

Winsol (from version 1.21)

The *Winsol* program allows the acquisition and analysis of measurements recorded by the Bootloader.

Since *Winsol* can also be used as a visualisation program with other interface modules (data loggers), the setup menu allows a choice of different devices.

SETUP

The setup contains the settings required for correct communication between the PC and the Bootloader.

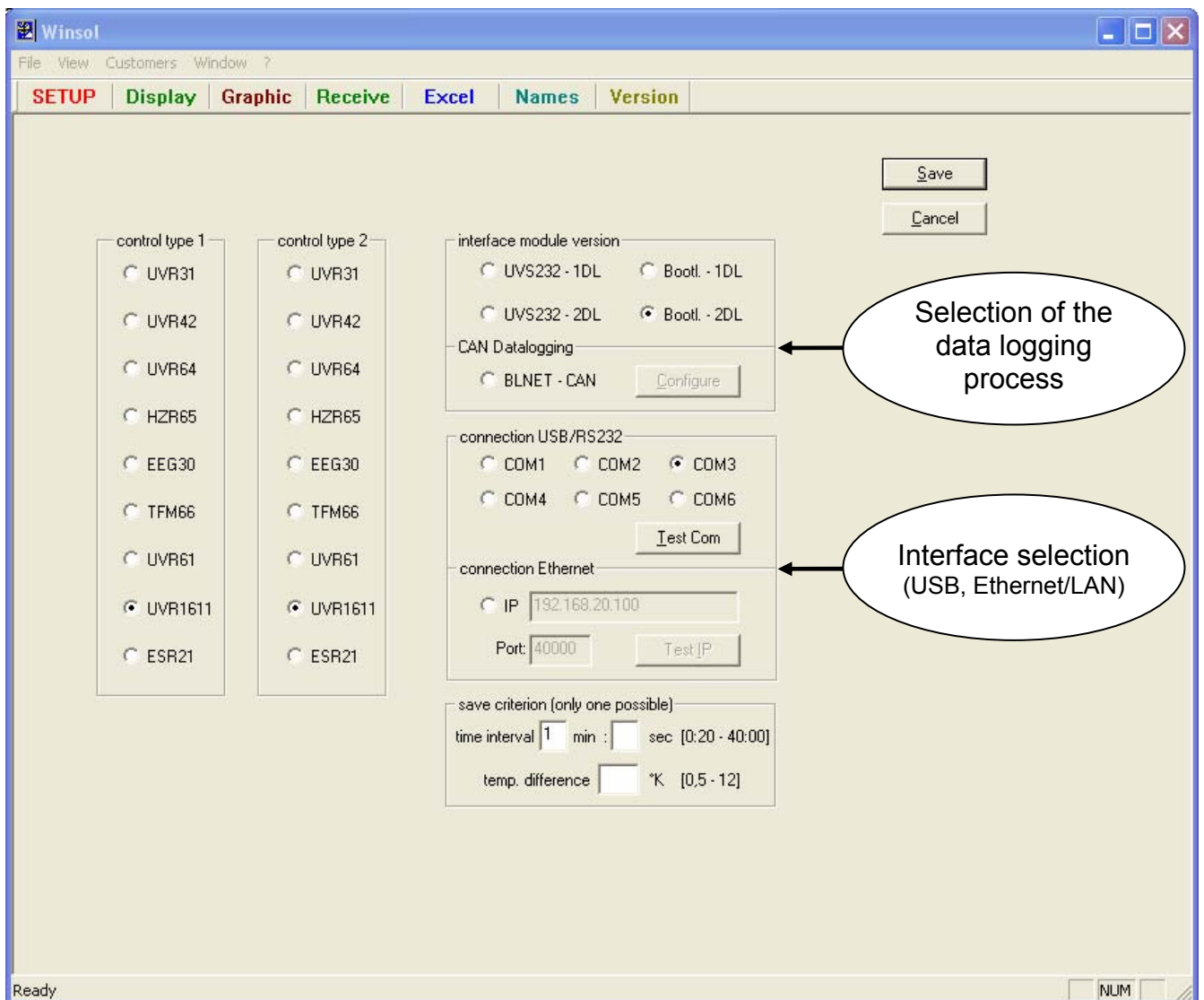

Selection of the data logging process

From here, a selection is made as to whether data logging takes place over the DL bus or the CAN bus (from *Winsol* version 1.20)

Setting for data logging over the DL bus.

or

CAN - Data logging setting

The desired values for CAN data logging must be defined **at the controller** under the menu **"Network/Data logging"** or with the program **"TAPPS"**.

Hence it is also possible, to log output variables from functions at the same time (e.g. the calculated nominal pre-run temperature of the heating circuit).

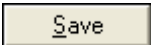
 **The boot loader only changes the data logging process, if the settings are saved.**

Data frame configuration

 Select the data frames, which should be logged by the boot loader.

CAN Configuration

Number: 2

Frame 1: CAN-Node 1: 1, Dataframe 1: 1

Frame 2: CAN-Node 2: 1, Dataframe 2: 2

Frame 3: CAN-Node 3: , Dataframe 3:

Frame 4: CAN-Node 4: , Dataframe 4:

Frame 5: CAN-Node 5: , Dataframe 5:

Frame 6: CAN-Node 6: , Dataframe 6:

Frame 7: CAN-Node 7: , Dataframe 7:

Frame 8: CAN-Node 8: , Dataframe 8:

choose name for input/output: sensor/output

Number : Up to 8 data frames can be configured for a number of UVR 1611s.

CAN Node: Specification of the controller node number, the data of which are to be logged.

Dataframe: Each controller can output a maximum of 26 digital and 32 analogue values that are defined in the menu "**Network/Data Logging**" of the UVR 1611. Each data record comprises 13 digital values, 16 analogue values and 2 heat quantity counters.

Therefore the data are divided into 2 data records if more than 16 analogue or 13 digital values or 2 heat quantity counters are to be logged per controller, or if values with numbers corresponding to the 2nd data record are entered:

	Digital	Analogue	HQC
Dataframe 1	1 – 13	1 – 16	1 - 2
Dataframe 2	14 – 26	17 – 32	3 - 4

Selecting input or output identification: To identify inputs and outputs in the **Display**, the descriptions "Analog/Digital" or "Sensor/Output" are available.

Connection type selection

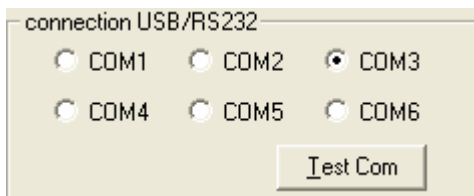

BL-Net connection via USB (virtual COM port)
 The "**Test Com**" command allows an automatic search for the Bootloader at the COM ports (COM 1-6) supported by *Winsol*, independently of any current setup settings.

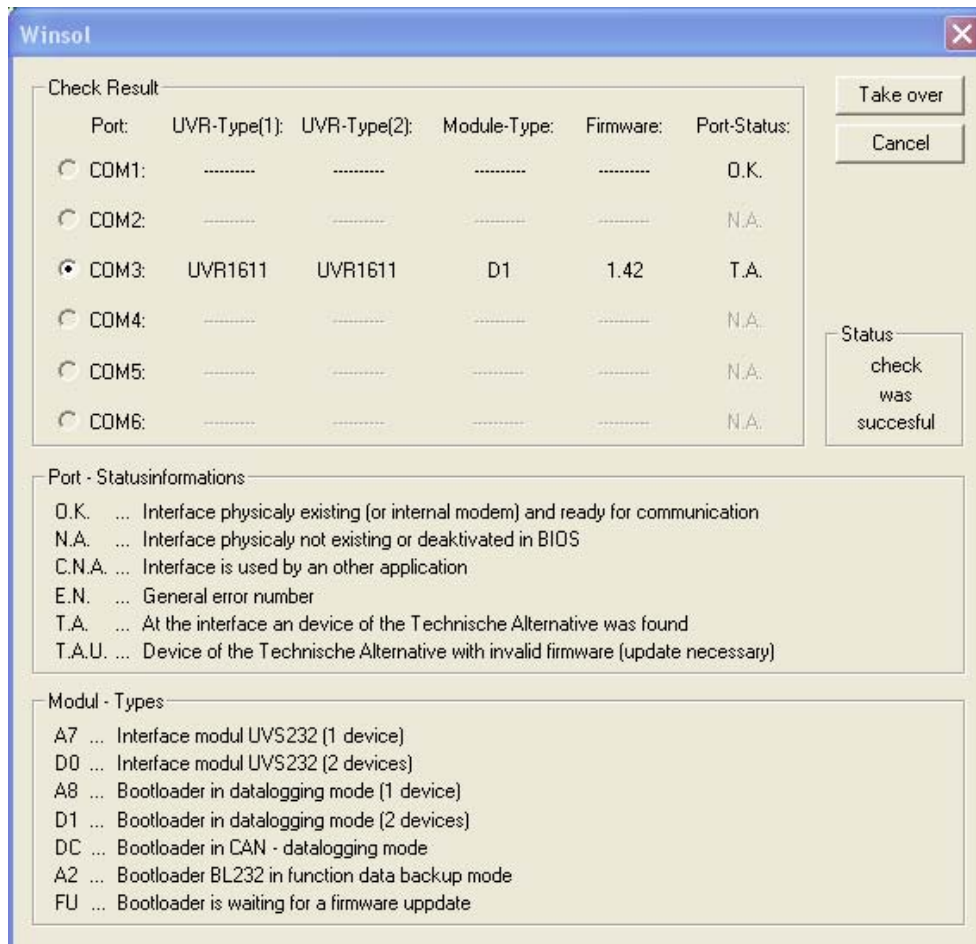

The type and number of the controllers to be logged are automatically identified by the Bootloader during DL data logging (module identification "A8" or "D1"). With "Test Com" the Bootloader always shows the type of the last device acquired. During CAN data logging, the number of data frames is displayed here (as in the section "Test IP"). CAN data logging must be activated in the program *Winsol* (see chapter "Selection of the data logging process"). Clicking "Take over" transfers the determined parameters into the setup.

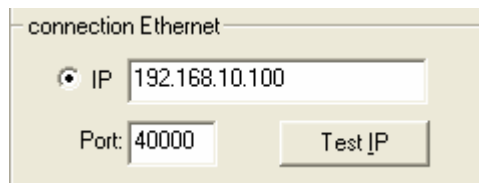

With BL-NET it is possible to communicate via Ethernet (LAN/computer network). To do this, the "IP" connection must be selected. The IP address or domain name of the BL-NET and its TA port must also be set. The Ethernet interface is only activated when power for the BL-NET is provided over the CAN bus!

When first commissioning, or if problems occur with the Ethernet interface, please follow the instructions in the section "**Connecting the BL-NET to a LAN Network**".

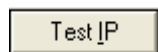

"Test IP" has the same function as "Test COM", but for the Ethernet connection. "Test IP" only returns a valid result when the Ethernet interface of the BL-NET has already been parameterised and the IP address and port of the Bootloader have been correctly specified in the *Winsol* setup.

See also the section "Connecting the BL-NET to a LAN network"

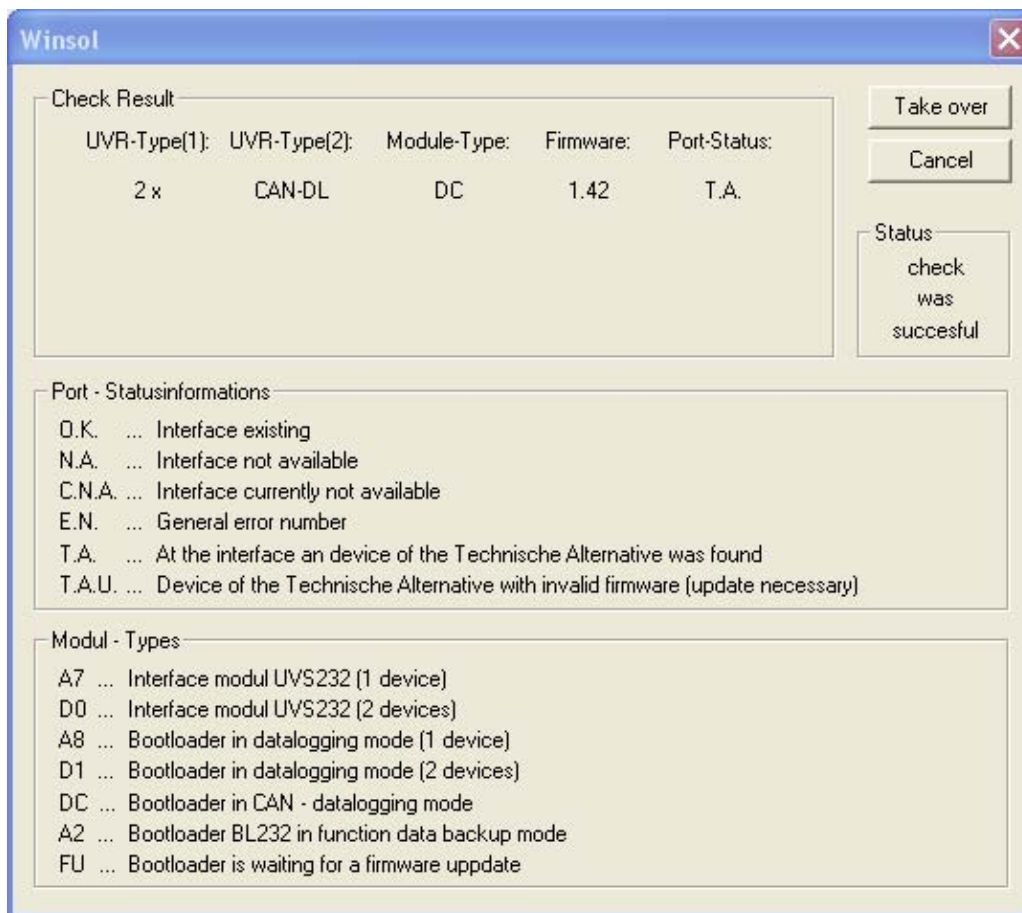

In this example, CAN data logging has been selected (module type "DC"). Consequently the number of data frames is displayed "2 x CAN-DL" = 2 data frames for CAN data logging). Clicking "Take over" transfers the determined parameters into the setup.

Save criterion

save criterion (only one possible)

time interval min : sec [0:20 - 40:00]

temp. difference °K [0,5 - 12]

The **save criterion** defines when the Bootloader should store a "data record" (all acquired measurements at a given time) in the *.log-file.

Two **optional** criteria are available for data logging over the DL bus (one of the two must be selected).

When data logging using the CAN bus, **only** the time interval can be selected.

- **Time interval**

Any value may be entered for the time criterion but the system uses an internal resolution of 20-second steps. Values are always rounded down (e.g.: Entry = 50 sec ⇒ Criterion = 40 sec). A small time period leads to large data volumes and is only recommend for brief detailed examinations. In addition to this, with save criterion below one minute not all data records can be converted into an Excel table because Excel can only manage a maximum of 65536 rows per table.

- **Temperature difference (only for data logging over DL)**

A save criterion of 3K is recommended for fault analysis purposes. A "data record" is saved every time a measured temperature changes by more than 3K or when an output state changes. The maximum time resolution is 10 seconds when doing this.

The maximum number of "data records" that the Bootloader can store depends on the type and number of controllers to be acquired.

Max. number of data records (data logging over DL-bus)	Controller type:	with 1xDL:	with 2xDL:
	UVR1611, UVR61-3	8000	4000
	ESR21 ESR31	16000	8000
	All others	32000	16000

Max. no. of data records (CAN- data logging)	1 frame	2 frames	8 frames
Data records:	8000	4000	1000

A storage overrun leads to overwriting of the oldest data.

Save

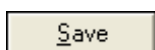

The **"Save"** command transfers the selected save criterion to the Bootloader and saves all setup settings on the PC.

Each time a command is executed from the menu bar, **Winsol** accesses the stored settings. **This means that changes must always be saved before a different menu is accessed!**

Display

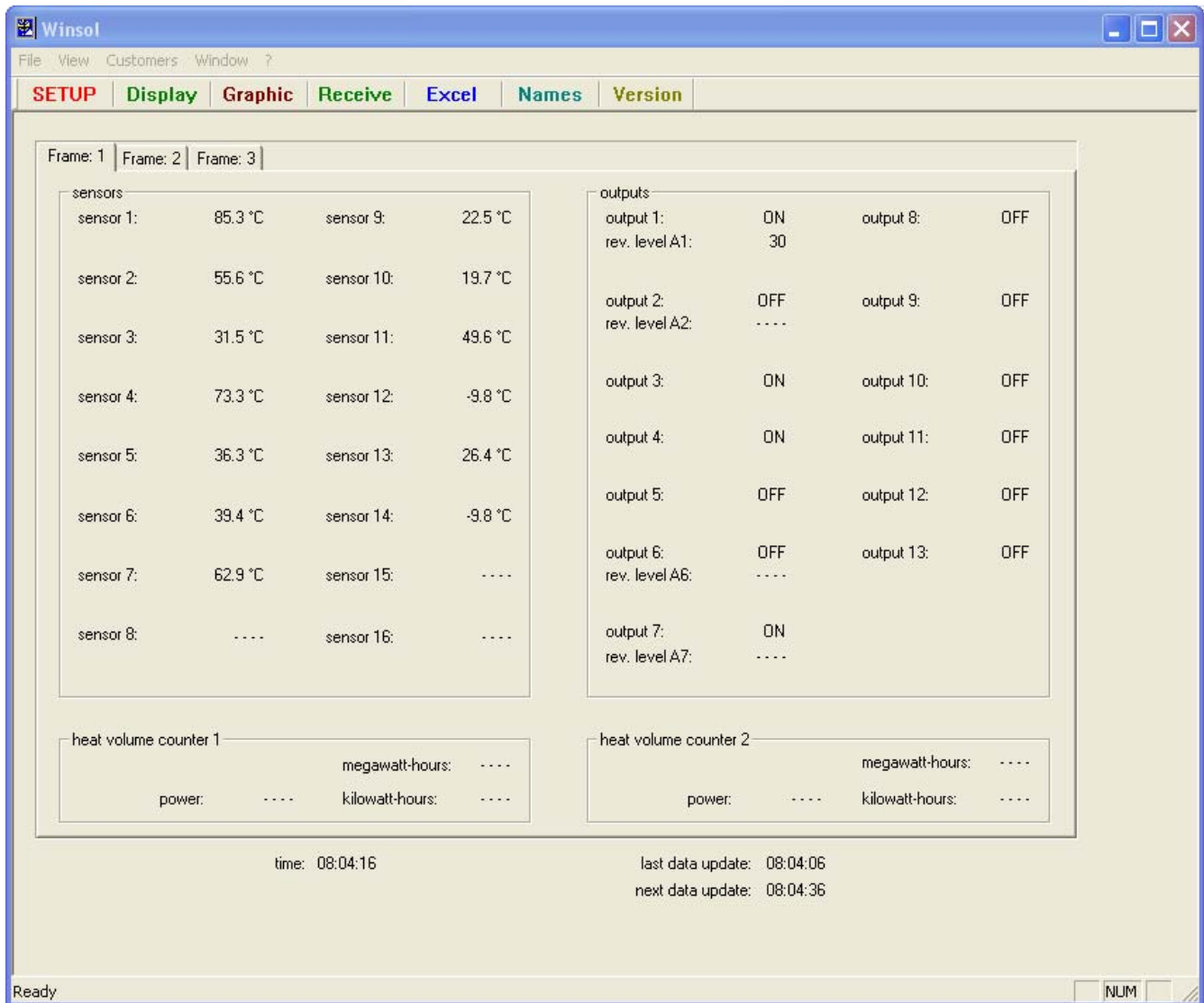

This window shows a table of the current measurements of the controllers connected to the Bootloader. The displayed time is that of the PC being used.

The **"Display"** function is the quickest and easiest way of checking the "controller → Bootloader" data connection.

If output 14 of the UVR1611 is set to "NETW.IP.=>DL.: yes", then the current measurements at the network inputs during data logging over the DL bus are displayed on an extra tab as device 2. If "NETW.IP.=>DL.:" "yes" is changed over to "no", the Bootloader must be quickly turned off and on and **"Test Com"** or **"Test IP"** executed.

When logging the data over the CAN bus the data for each frame are available on a separate tab for each frame. The analogue and digital values are identified similarly in all frames ("sensor xx" or "output xx"), therefore it makes sense to give each value its own **"name"** (see next section)

Only the last update values are ever shown. Even when switching from one tab to the next, the current values are only shown when the next update is carried out. The time of the next update is shown at the bottom of the window.

Names

This menu allows the definition of "**Display**", "**Graphic**" and "**Excel**" user-defined names for the acquired measurements (e.g. external temperature, room temperature etc.).

Receive

The "**Receive**" command reads the measured data stored in the Bootloader and saves it as a LOG file in the *Winsol* file system on the PC. A separate LOG file is created in the corresponding subdirectory ("...\log") for each month. When logging data from two controllers or some frames, *Winsol* saves the data in separate subdirectories "...log1" and "...log2" etc.. The filenames of LOG files contain year and month information of the data. For example, the file "Y200712.log" contains measurements from **December 2007**.

Note: When acquiring data from several systems, before reading the data it is essential to select the correct "**customer**" (see *customer mode*)!

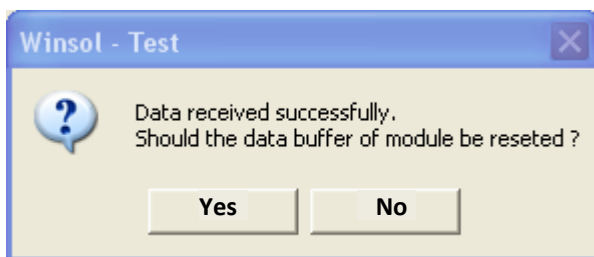

The process of reading "**own data**" (customer: "own data") **automatically** deletes the data storage of the Bootloader, but in the customer mode it is possible to specify that the data in the Bootloader is retained. It is recommended that after successfully reading in the data, the data is then deleted from the data converter. The data is deleted in the *Winsol* menu "File/module".

If a power failure occurs when logging data from controllers that do not have an internal clock then only the data recorded by the Bootloader after the power failure can be edited. A time-stamp can no longer be generated for earlier data.

Autostart

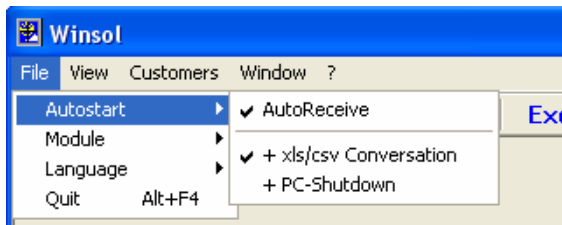

The data can be automatically read when the PC starts up, via the options in the "**File \ Autostart**" menu.

"AutoReceive"

If this option is activated, the data which have been selected in the menu "Manage customers" are, upon booting of the PC, automatically read in and saved by the boot loader. The customers selected for the autoreceive process are read in in alphabetical order (see selection box in "Manage customers" dialogue). After reading-out, the data are automatically deleted from the boot loader.

There is a possibility of using Windows own functions "Scheduled tasks" (Windows XP) or "Task scheduler" (Windows Vista, Windows 7) to initiate automatic reading in on a running PC.

"AutoReceive + xls/csv Conversation"

In addition to "AutoReceive" after the reading in, *.xls- or *.csv files are automatically created with the settings specified in the function "EXCEL". In this respect, files are created for the months contained in the read-in data. Existing files are overwritten.

"AutoReceive + PC-Shutdown"

This option is possible in addition to "**Autoreceive**" and "**Autoreceive + xls/csv conversion**". Here, as the PC boots up, the data are automatically read in (incl. possible xls/csv conversion) and then the PC shutdown after the subsequent countdown.

This function is intended for computers that are used exclusively for data acquisition. In this case the PC must be automatically powered up at specific times. This can be done with (e.g.) an external power timer that provides power to the PC at appropriate times and by making appropriate BIOS settings (power up when mains voltage is present).

Graphic

This window shows a daily representation of the recorded data (LOG files). The **"Help"** menu item shows a list of the available key commands. It is possible to move the cursor, zoom in and out on the graph, switch auto-scaling, grid and cursor on or off, display "Help", print the graph and display or hide the output or temperature graphs.

In the menu **"Graphs \ select graphs..."** you can chose those parameters from all the devices or data frames which are to be displayed on the graph (up to 14 input and up to 10 output parameters simultaneously). Once the maximum number is reached, it is not possible to select any further parameters. Here also, the analogue or digital values are identified as "sensor xx" or "output xx".

This option means the graph can be reduced to a few desired parameters so that it is clearly laid out and easy to understand.

The entire selection is deleted by pressing **"Cancel selection"**.

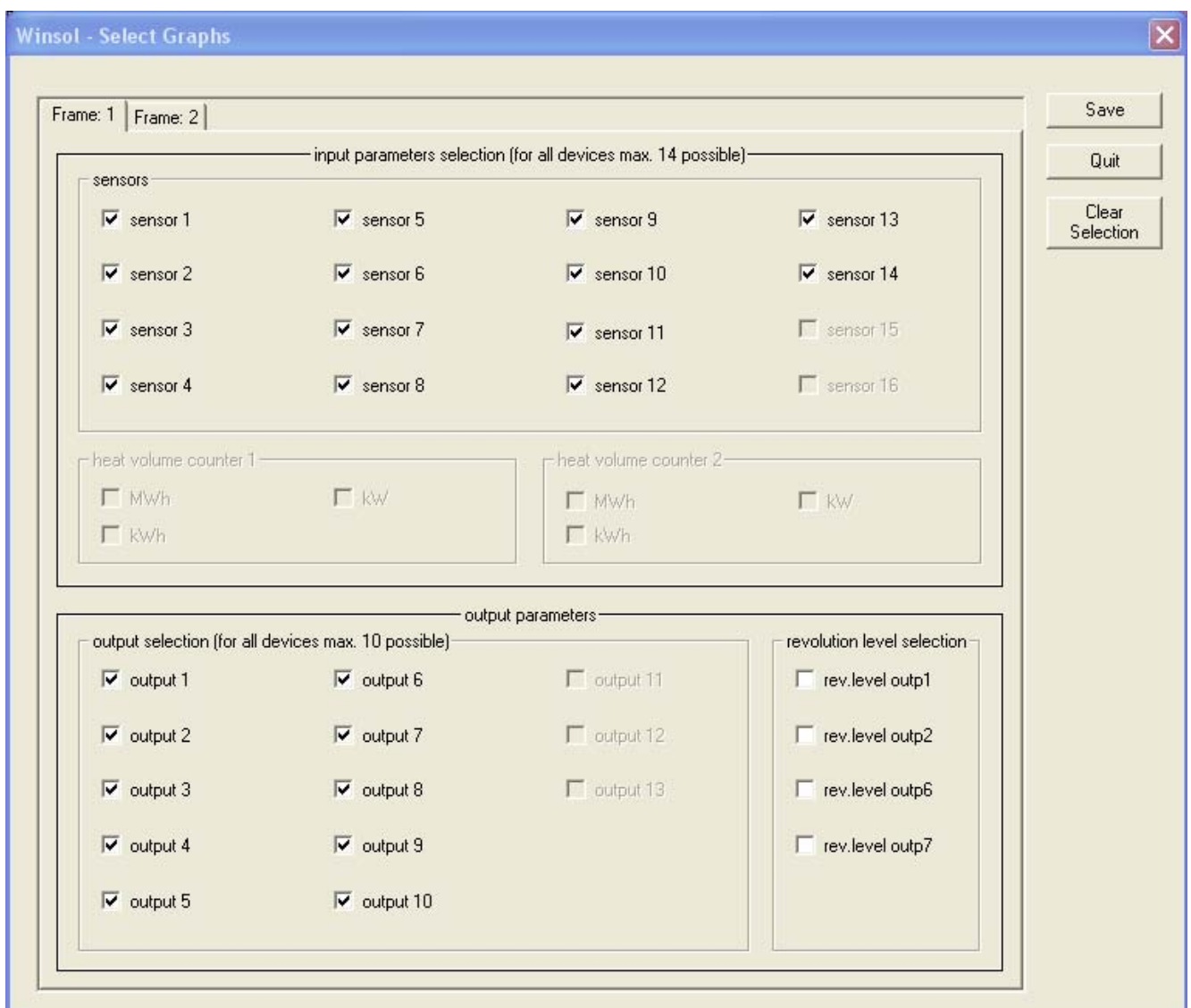

Actual system example (1 controller, data logging over DL bus):



Cursor

Cursor: The menu item "Help" shows the list of available keyboard commands. Thus for example, the cursor can be moved with the keys "←" and "→", the arrow keys "↑" and "↓" can be used to navigate on the graph forwards or backwards by a day.

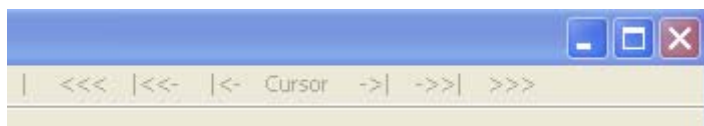

The cursor can also be moved using the top right arrow buttons (by one measurement interval, one hour or one day).

All values (date, time, sensor values, output conditions, etc.) **at the cursor position** are displayed at right or top edge of the screen.

By selecting "Autoscale" in the menu "Graphs" the scale of the Y-axis is matched to the values.

"ZOOM IN" or "ZOOM OUT" are used to expand or shorten the time X-axis over the course of the day.

Optimum display resolution is achieved by maximising the window to the screen size.

Excel

This menu allows conversion of the LOG files into the *.xls or *.csv format, for further processing in any desired spreadsheet program supporting these formats. This allows the creation of graphics and statistics using the recorded measurements. To adjust the generated table to suit the language-specific requirements, a comma or a full-stop can be specified as the decimal separator when generating the *.csv file.

The created files are stored as daily or monthly data in the corresponding **Winsol** subdirectory ("...\Excel"). As with the LOG files, the name of the generated file contains information on the date of the measurements it contains. For example, the day file "E090609.csv" contains measurements acquired on 09th June 2009. An existing file of the same name is overwritten. A month file E0906 contains the measurement data for the month June 2009.

When logging data from **two** controllers or frames **Winsol** generates files in three directories ("...\Excel", "...\Excel1" and "...\Excel2") with a combined data record in one directory and the respective separate data records in the other two directories.

However in the *.xls file format only a maximum of 2 controllers or data frames can be saved in the **same** file.

If more than 2 data frames are to be logged, it is therefore advisable to create *.csv files, as here up to 8 possible frames can be stored for the same data record in the directory "...\Excel". Subsequently individual files are likewise created for each data frame in the appropriate number of directories.

The settings are saved during conversion.

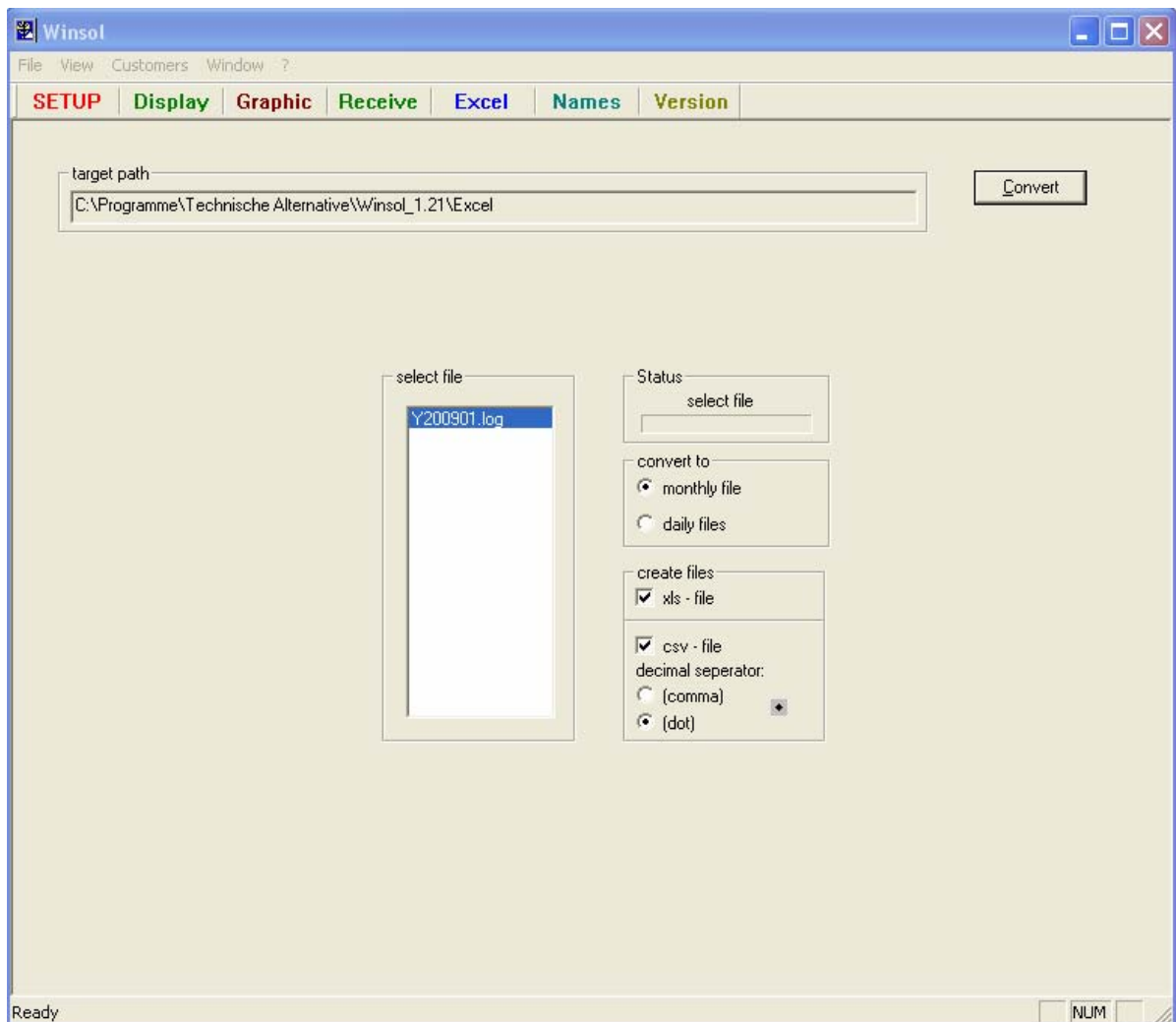

Typical *.xls file:

	A	B	C	D	E	F	G	H	I	J
1	time stamp	sensor1/1	sensor2/1	sensor3/1	sensor4/1	sensor5/1	sensor6/1	sensor7/1	sensor8/1	sensor
2	04.03.2010	0,8	67,1	70,2	70,3	42	36,6	61,6	33,9	1
3	04.03.2010	0,8	67,1	70,2	70,3	41,6	36,6	61,6	33,9	1
4	04.03.2010	0,8	67,1	70,2	70,3	41,3	36,6	61,6	33,9	1
5	04.03.2010	0,8	67,1	70,2	70,3	41,1	36,6	61,5	33,8	
6	04.03.2010	0,8	67,1	70,2	70,3	40,9	36,6	61,4	33,8	1
7	04.03.2010	0,8	67,1	70,2	70,3	40,7	36,6	61,4	33,8	1

Typical *.csv file:

	A	B	C	D	E	F	G	H	I	J	K	L
1	date	time	device1:	sens1/1	sens2/1	sens3/1	sens4/1	sens5/1	sens6/1	sens7/1	sens8/1	sen
2												
3	04.03.2010	19:22:20		0,8	67,1	70,2	70,3	42	36,6	61,6	33,9	
4	04.03.2010	19:22:50		0,8	67,1	70,2	70,3	41,6	36,6	61,6	33,9	
5	04.03.2010	19:23:10		0,8	67,1	70,2	70,3	41,3	36,6	61,6	33,9	
6	04.03.2010	19:23:30		0,8	67,1	70,2	70,3	41,1	36,6	61,5	33,8	
7	04.03.2010	19:23:50		0,8	67,1	70,2	70,3	40,9	36,6	61,4	33,8	

Customer mode

Winsol allows not only the management and analysis of "own data", it can also be used for analysing the data from other systems. For technical experts, this is an important tool for functional monitoring and troubleshooting customer systems.

Separate customer folders can be created and selected in the "**Customers / manage customers...**" menu. A folder is created in the *Winsol* file system for each customer, in which the corresponding configuration and LOG files are stored. The "**Infosol**" directory in the *Winsol* program folder contains all these customer folders. After creation of a customer, the criteria must be specified in the **SETUP** as well as execution of "**Test Com**" or "**Test IP**".

The currently selected customer is displayed in the *Winsol* title bar (e.g. "*Winsol* – Bloggs"). If no customer name is displayed in the title bar, then the "own files" are selected.

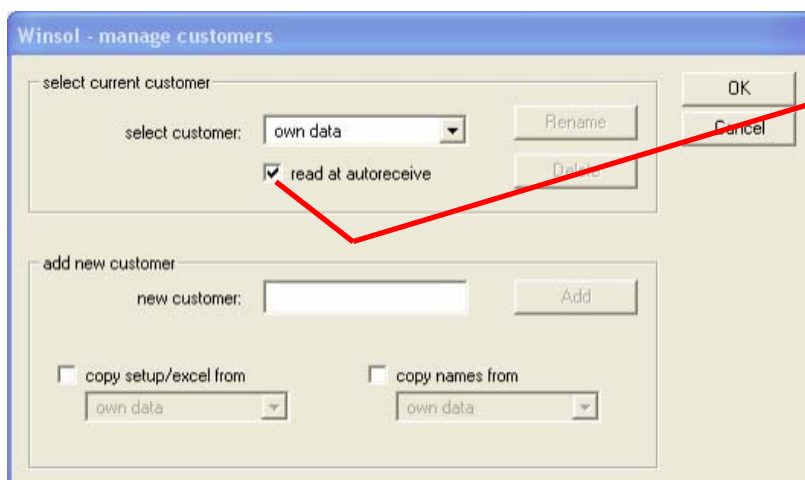

From *Winsol* 1.21 the "Manage customers" dialogue can be used to specify for which customers (multiple selection possible) data should be read in during the autoreceive process. In the factory, the Autoreceive process is carried out for "own data".

There are three ways of acquiring the measurements for a customer system:

1. The Bootloader is installed with the system and is regularly read on-site by a service technician using a notebook.
2. If the customer acquires the system measurements, then he/she can email the LOG files to the technical expert.
3. If the recorded data cannot be acquired on-site, then the measurements can be acquired as follows:

Preparation of the data logging:

- 1) Connect the Bootloader to the PC **without** using a DL connection (power supply via CAN-bus or battery). If CAN data logging is activated on own controller, then the CAN connection must also be interrupted and the power supply **only** be provided from the battery.
- 2) Create and select a customer in *Winsol* for the data to be acquired.
- 3) Define the desired save criterion in setup (possibly after "**Test Com**") and transfer this to the Bootloader via "**Save**".

Data acquisition at the customer site:

- 4) Connect the Bootloader to the controller (ensure correct polarity!!). With a UVR1611, the data output must be activated (define output 14 as a data line) for output over the DL bus. For output over the CAN bus, the desired values must be set in the menu "Network/data logging".
- 5) As long as the Bootloader is connected to the controller, the measurements are recorded according to the selected save criterion.
- 6) When the Bootloader is disconnected from the controller, the time and date must be noted because *Winsol* requires this information in order to assign the correct time when reading the data. This is not necessary with the UVR1611 and UVR61-3.

Read the recorded data:

- 7) Connect the Bootloader to the PC via USB **without** using a DL- or CAN-connection (power supply via battery).
- 8) The data stored in the Bootloader can now be read by selecting "**Receive**" and specifying the noted time, then analysed as desired.

Troubleshooting

◆ The BL-NET Bootloader is not recognized by the *Winsol* "Test IP" function.

1. For communication via Ethernet, the Bootloader must be connected to the CAN bus or supplied with power via a 12V power adaptor (special accessory CAN-NT).
2. Make sure that the Bootloader is connected via Ethernet to the PC or LAN network. An existing Ethernet connection is indicated by a green LED in the oval window on the lower side of the Bootloader. A **crossed** network cable must be used for direct connection with a PC.
3. With a direct Ethernet connection between BL-NET and a PC, the PC must be assigned a fixed IP address. If the PC has a WLAN (wireless network), it must be ensured that the network related part of the IP address differs from the WLAN part.
4. Check the Ethernet configuration of the BL-NET (see chapter "**Connecting the BL-NET to a LAN network**") and note the IP address and TA port of the Bootloader.
5. Make sure that the same IP address and TA port of the Bootloader are set in the *Winsol* setup.
6. Run "Test IP" again. Note the displayed port status.

6.1. C.N.A.

If the interface is already being used by another application, this must be ended in order to communicate with the Bootloader. Multiple applications cannot access the interface at the same time.

◆ The Bootloader is not recognised by the *Winsol* "Test Com" function.

1. Make sure that the Bootloader is connected via USB to the PC.
2. In the Windows *Device Manager*, check that the USB driver was correctly installed (Device Manager ⇒ Ports) (COM und LPT)). In this case the virtual COM port appears in the list as "USB Serial Port".
 - 2.1. If the driver is not correctly installed, then perform the installation again (see chapter "**USB driver \ Installation**").
 - 2.2. If the driver has been assigned a COM port that is not supported by *Winsol* or *Memory Manager* (e.g. "USB Serial Port (COM12)"), change this setting (see chapter "**USB driver \ Configuring the virtual COM port**").

3. Run "Test Com" again. Note the displayed status of the COM port assigned to the USB driver.

3.1. C.N.A.

If the interface is already being used by another application, this must be ended in order to communicate with the Bootloader. Multiple applications cannot access the interface at the same time.

4. If no controller is connected to the BL-NET then a 9V battery must be used to provide power for the device.
5. If the Bootloader is connected to at least one device, check the data transfer from the controller to the Bootloader (*see next point*).

◆ **The data transfer from the controller to the Bootloader is not working.
(No measurements are shown in *Winsol Display*.)**

1. Make sure that the Bootloader is connected to the controller via the DL data cable.
2. Check the **wiring** of the data cable and observe the correct polarity.
3. With the UVR1611 data output must be activated if logging over the data link (DL-bus) is to take place (output 14 defined as "**data link**").
4. Ensure that, the BL-NET is configured for the corresponding data logging process (DL-bus or CAN bus (*see Winsol* chapter)).
5. If two controllers are to be acquired with the Bootloader, check the data connection with each of them individually in order to isolate the problem. To do this, remove the data cable (DL bus) or the CAN bus from each of the controllers one after another. It is important to disconnect the cable directly at the controller and not at the data input of the BL-NET, otherwise you may get ambiguous results!
 - 5.1. If the data transfer works with each of the two controllers individually, then the problem is caused by crosstalk errors between the two data cables (DL-bus). In this case the cables must be laid separately or at least one cable must be shielded.
6. To isolate data transfer problems with a single cable, test the link using a short cable (< 1 metre).
 - 6.1. If the data transfer works with the short cable then the problem is caused by interference from an external source in the long cable. In this case, the cable must be laid using a different path or a shielded cable must be used.
7. If problems persist after all the above points have been checked then please consult your dealer or directly contact the manufacturer. The problem can only be solved with an **exact fault description!**

◆ The data is recorded with the wrong timestamp (date, time).

1. When logging from an UVR1611 or UVR61-3, the timestamp is generated by the controller and, in this case, the time information at the controller must be corrected.

Note: To ensure a high time resolution, the Bootloader synchronises its clock with the controller during commissioning, or once a day, and updates the timestamp internally. If the time in the controller is changed, the Bootloader must therefore be briefly powered off for a few seconds (remove DL) so that it immediately synchronises after a restart.

2. When logging data from controllers without internal clocks, the time on the PC, or the time at which the Bootloader was disconnected from the controller, is assigned to the recorded data.

◆ The log and Excel files are not displayed in the corresponding path or the searched for folder itself does not even exist

Under certain circumstances, Windows 7 and Windows Vista, create the files in a "virtual program path". In Windows Explorer, the searched for files are reached by pressing the button "Compatibility files":

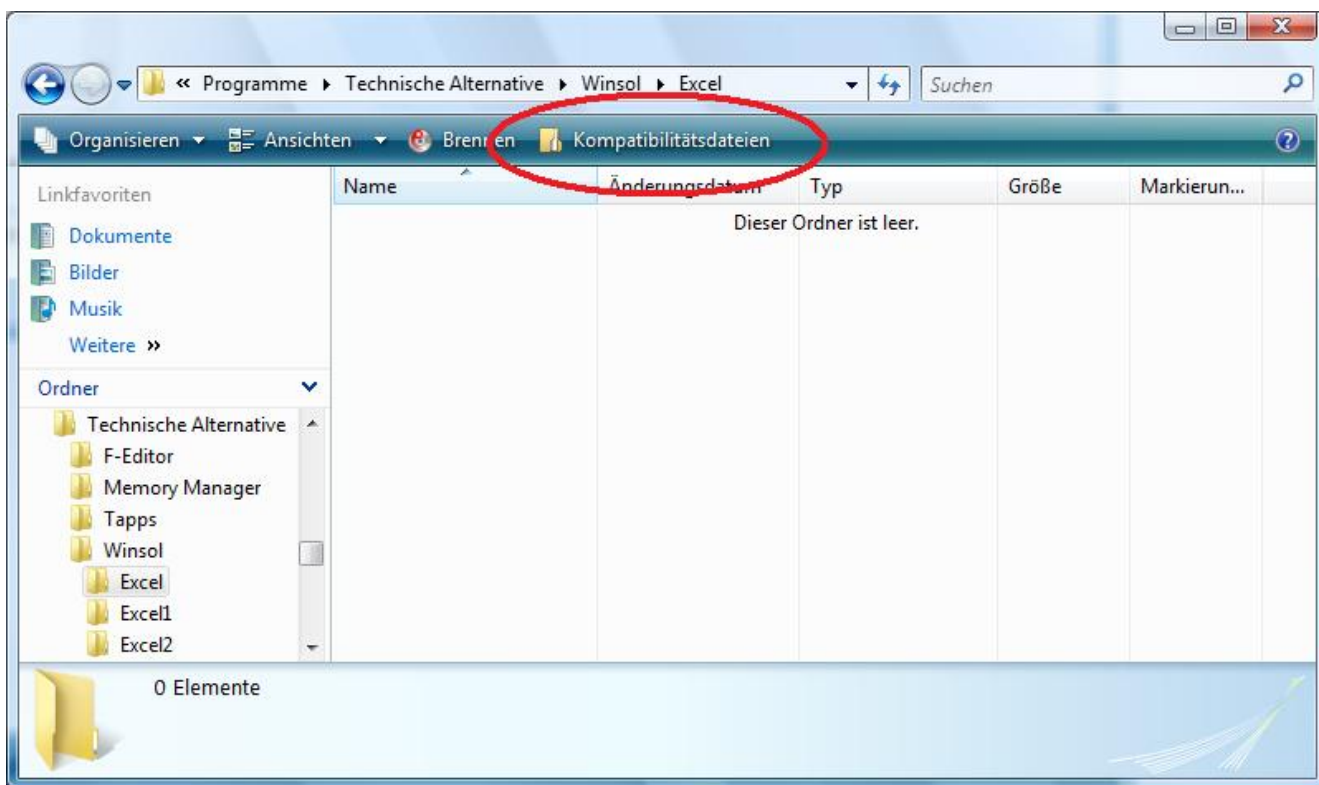

The files are then actually stored in the following path:

C:\Users\USERNAME\AppData\Local\VirtualStore\Programme\Technische Alternative\Winsol\...

Memory Manager (from version 2.07)

The *Memory Manager* program allows updating of the operating system of the Bootloader, and other devices connected to the CAN bus (UVR1611, CAN monitor, etc.). Functional data can also be copied in both directions (data upload and download).

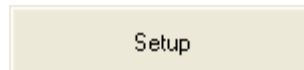
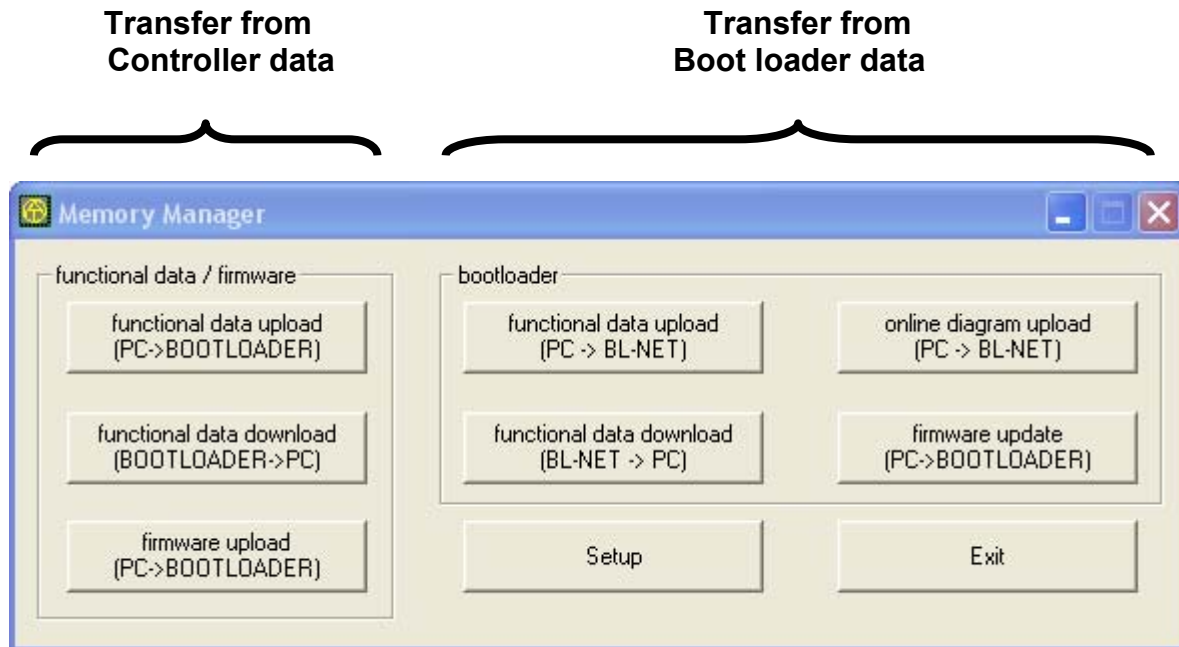

The setup contains the settings required for correct communication between the PC and the Bootloader.

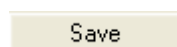
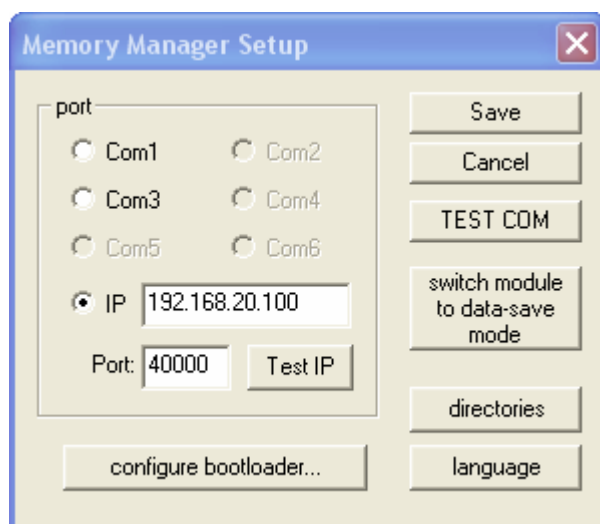

Saves the set interface parameters



The **"Test Com"** command allows an automatic search for the Bootloader at the COM ports supported by *Memory Manager*, independently of any current setup settings.

Test IP

"**Test IP**" has the same function as "Test COM", but for the Ethernet connection. "**Test IP**" only returns a valid result when the Ethernet interface of the BL-NET has already been parameterised and the IP address and port of the Bootloader have been correctly specified.

switch module to data-save mode

This is only required for the BL232 Bootloader, with the BL-NET the storage is large enough to save both the logged data and the system data at the same time.

directories

Selection of the **standard directories**

language

Memory Manager language selection

configure bootloader...

The menu is used for configuring the basic settings of the BL-NET (see "**Connecting the BL-NET to a LAN network**"):

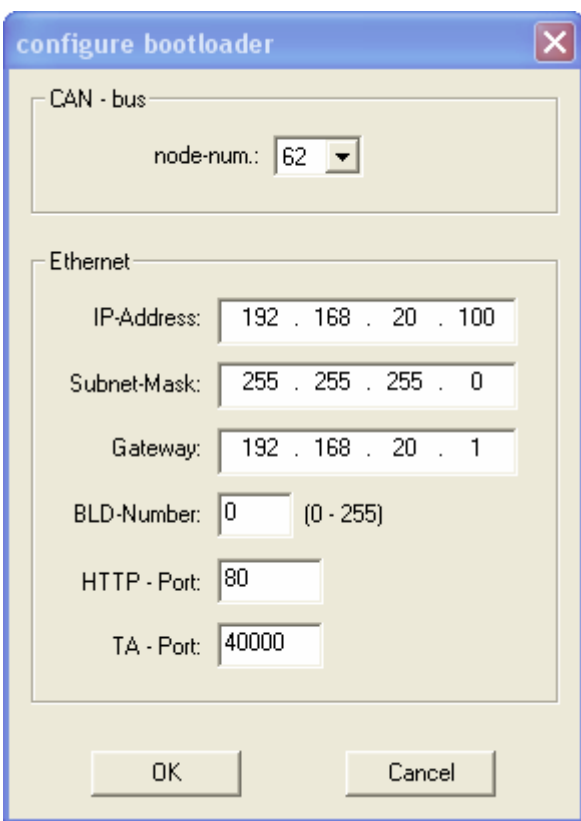

Node number of the BL-NET in the CAN network

IP address of the BL-NET

Subnet mask of the BL-NET

Gateway of the BL-NET (not used)

Bootloader number (= last position of the MAC address)

HTTP port for web browser access

TA PORT for communication with *Memory Manager* and *Winsol*

Transfer of controller data

Transfer of the controller data is started from the left area of the *Memory Manager*:

functional data / firmware	
functional data upload (PC->BOOTLOADER)	Functional data upload (PC→Bootloader)
functional data download (BOOTLOADER->PC)	Functional data download (Bootloader→PC)
firmware upload (PC->BOOTLOADER)	Firmware upload (PC→Bootloader)

The Bootloader has 7 memory positions for functional data and one memory position for the operating system. All memory positions can be used simultaneously!

Functional data upload (PC→Bootloader)

Transfers functional data (*.dat) from the PC to the Bootloader.

The screenshot shows a dialog box titled "Memory Manager selection functional data upload (BL <= PC)". It contains a table with 7 rows, each representing a memory position. The columns are: "memory position / designation at bootloader:", "overwrite", and "source file at PC:". The first row is selected, with "otte" in the first column, a checked "overwrite" checkbox, and "otte" in the source file field. Below the table are "Delete", "Start Transfer", "Cancel", and "Reset" buttons.

memory position / designation at bootloader:	overwrite	source file at PC:
1: otte Delete	<== <input checked="" type="checkbox"/>	otte select properties...
2: PRO1420 Delete	<== <input type="checkbox"/>	 select properties...
3: Funktionsdaten CAN - Monitor Delete	<== <input type="checkbox"/>	 select properties...
4: Funktionsdaten 09.06.2009 13_30 Delete	<== <input type="checkbox"/>	 select properties...
5: no valid data Delete	<== <input type="checkbox"/>	 select properties...
6: no valid data Delete	<== <input type="checkbox"/>	 select properties...
7: no valid data Delete	<== <input type="checkbox"/>	 select properties...

Start Transfer Cancel Reset

The left column shows the data that is currently stored in the Bootloader. Setting a tick in the "**overwrite**" column selects the functional data on the PC that will then be written to the corresponding memory position in the BL-NET.

Clicking "**Start Transfer**" loads the selected data into the Bootloader.

Functional data download (Bootloader→PC)

The functional data previously loaded from the controller into the Bootloader is stored on the PC.

memory position / designation at bootloader:	save	target file at PC:
1: otte	<input type="checkbox"/> ==>	<input type="text"/> <input type="button" value="select"/>
2: PRD1420	<input type="checkbox"/> ==>	<input type="text"/> <input type="button" value="select"/>
3: Funktionsdaten CAN - Monitor	<input type="checkbox"/> ==>	<input type="text"/> <input type="button" value="select"/>
4: Funktionsdaten 09.06.2009 13_30	<input type="checkbox"/> ==>	<input type="text"/> <input type="button" value="select"/>
5: no valid data	<input type="checkbox"/> ==>	<input type="text"/> <input type="button" value="select"/>
6: no valid data	<input type="checkbox"/> ==>	<input type="text"/> <input type="button" value="select"/>
7: no valid data	<input type="checkbox"/> ==>	<input type="text"/> <input type="button" value="select"/>

The data stored in the Bootloader is shown in the left column. Setting a tick in the "save" field allows specification of the path and name of the file on the PC where the functional data is to be stored.

Clicking "Start Transfer" stores the selected data on the PC.

The functional data (*.dat) stored on the PC must be regarded as a backup copy and cannot be edited on the PC.

Using the *TAPPS* programming software an option exists to create and print out a *.txt file from the *.dat file containing a list of all the setting parameters used in programming (→see *TAPPS* tutorial).

Operating system upload (PC→Bootloader)

Transfer of an operating system (UVR1611, CAN monitor, CAN-I/O module or bus converter CAN-BC) from the PC to the Bootloader. Since a common memory position is used for the operating system, the transfer overwrites the existing operating system stored in the BL-NET. The latest operating system at any point in time can be downloaded to a PC from our home-page <http://www.ta.co.at>.

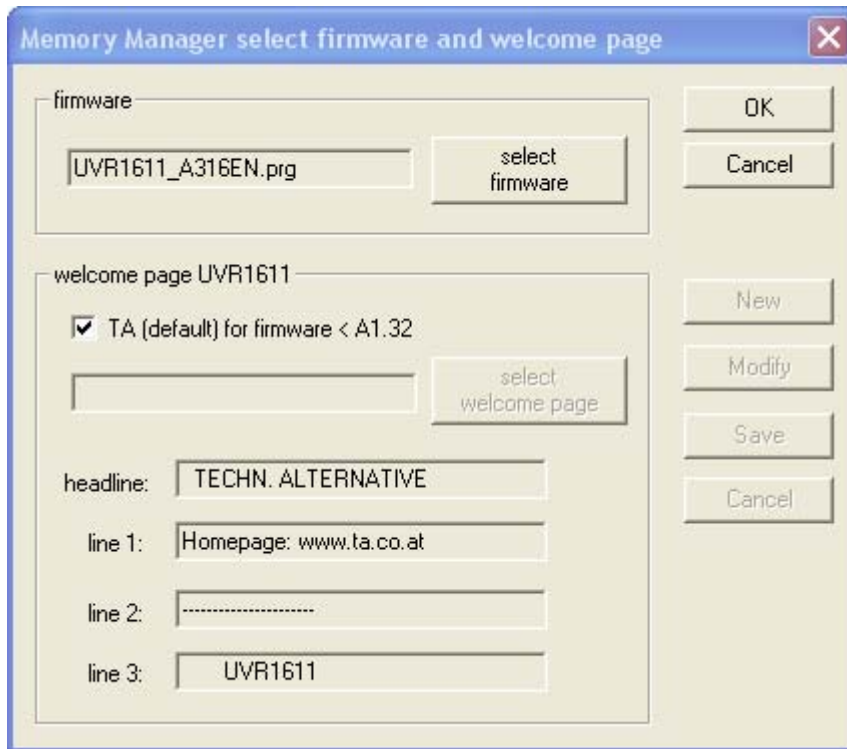

The desired operating system (*.prg) on the PC is selected with the “**select firmware**” button. When uploading an operating system for a UVR1611, a user-defined welcome page for the controller can also be defined. This greeting page can be created during creation of a function data record (“Export to the translator”) using the programming software *TAPPS*. If a welcome page is already defined in the controller functional data then this is retained and the welcome page specified when transferring the operating system is not adopted by the UVR1611.

Clicking “**OK**” starts the data transfer and stores the selected operating system on the Bootloader.

Transfer of Bootloader data

The right part of the Memory Manager is responsible for the transfer of Bootloader data:

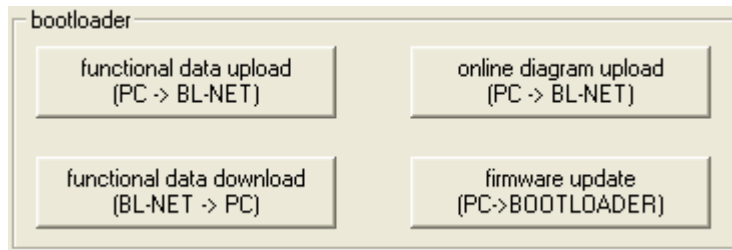

Functional data upload (PC ⇒ BL-NET)

Transfer of BL-NET functional data from the PC to the Bootloader.

The BL-NET configuration can be created directly on the device via web browser or using the software "F-Editor" on the PC.

Functional data download (BL-NET ⇒ PC)

The BL-NET Bootloader functional data is stored on the PC.

Online scheme upload (PC ⇒ BL-NET)

Transfer of the files for the BL.NET online scheme from the PC to the Bootloader. After selecting the file type (*.gif or *.html), the corresponding file can be selected and loaded into the Bootloader. **Both files** must be loaded sequentially. The files must not exceed the maximum permitted size of 196 kilobytes each.

More details about the online scheme can be found in tutorial for the *TAPPS* programming software.

Operating system update (PC⇒Bootloader)

The latest BL-NET operating system (*.frm) can be downloaded from <http://www.ta.co.at>.

CAUTION: Newer operating systems are not necessarily compatible with the software already present on the PC. The homepage provides information on this. The software on the PC should always be brought up to date **before** an operating system update.

It is advisable to backup the data stored in the Bootloader before performing an operating system update.

If the update is started in the *Memory Manager*, the Bootloader first loads the program into the internal memory (progress bar in *Memory Manager* is full) and then the processor is written with the new operating system. This procedure is indicated by alternate flashing of both LEDs on the Bootloader.

This is followed by a restart and the Bootloader is then ready for operation again.

Troubleshooting

◆ The BL-NET Bootloader is not recognised by the *Memory Manager* "Test IP" function.

1. For communication via Ethernet/LAN, the Bootloader must be connected to the CAN bus or supplied with power via a 12V power adaptor (special accessory CAN-NT).
2. Make sure that the Bootloader is connected via Ethernet to the PC or LAN network. An existing Ethernet connection is indicated by a green LED in the oval window on the lower side of the Bootloader. A crossed network cable must be used for direct connection with a PC.
3. With a direct Ethernet connection between BL-NET and a PC, the PC must be assigned a fixed IP address. If the PC has a WLAN (wireless network), it must be ensured that the network related part of the IP address differs from the WLAN part.
4. An existing WLAN (wireless network) must have a network address different from the Ethernet connection of the Bootloader (the first 3 number blocks of the IP address).
5. Check the Ethernet configuration of the BL-NET (see chapter "**Connecting the BL-NET to a LAN network**") and note the IP address and TA port of the Bootloader.
6. Make sure that the IP address and TA port of the Bootloader are set in the *Memory Manager* setup.
7. Run "Test IP" again. Note the displayed port status.

7.1. C.N.A.

If the interface is already being used by another application, this must be ended in order to communicate with the Bootloader. Multiple applications cannot access the interface at the same time.

◆ The Bootloader is not recognised by the *Memory Manager* "Test Com" function.

1. Make sure that the Bootloader is connected via USB to the PC.
2. In the Windows "**Geräte-Manager**" (*device manager*), check that the USB driver was correctly installed ("**Geräte-Manager**" (*device manager*) ⇒ "**Anschlüsse**" (*ports*) (**COM und LPT**)). In this case the virtual COM port appears in the list as "**USB Serial Port**".
 - 2.1. If the driver is not correctly installed, then perform the installation again (see chapter "**USB driver \ Installation**").
 - 2.2. If the driver has been assigned a COM port that is not supported by *Winsol* or *Memory Manager* (e.g. "**USB Serial Port (COM12)**"), change this setting (see chapter "**USB driver \ Configuring the virtual COM port**").
3. Run "Test Com" again. Note the displayed status of the COM port assigned to the USB driver.
 - 3.1. C.N.A.
If the interface is already being used by another application, this must be ended in order to communicate with the Bootloader. Multiple applications cannot access the interface at the same time.
4. If no controller is connected to the BL-NET then a 9V battery must be used to provide power for the device.

Connecting the BL-NET to a LAN network

Before connecting a BL-NET to a LAN network, it must first be configured **via the USB interface**:

1. The *Winsol* and/or *Memory Manager* program(s) must be installed on the PC.
2. Connect the Bootloader to the PC via USB. If the required USB driver is not installed on the PC, then this must be done now (see "**USB driver installation**").
3. For configuration, the Bootloader must be supplied with power via the CAN bus, a DL or a battery.
4. Start one of the abovementioned programs and click "TEST COM" in the setup area. The program searches for the Bootloader at the (virtual) COM interfaces (COM 1 to COM 6).
5. If a BL-NET is found, the interface can be automatically adopted in the setup via "**Take over**" and the setting can be saved via "**Save**". If the software does not find a BL-NET then either the device does not have a power supply (see 3.) or the software of another USB device is preventing recognition. In this case, the software of the relevant device must be exited during the recognition process.
6. In Windows, start a command shell via Start → "**Ausführen**" (run) by entering "**cmd**".
7. Determine the network settings of the PC via the "**ipconfig**" command:

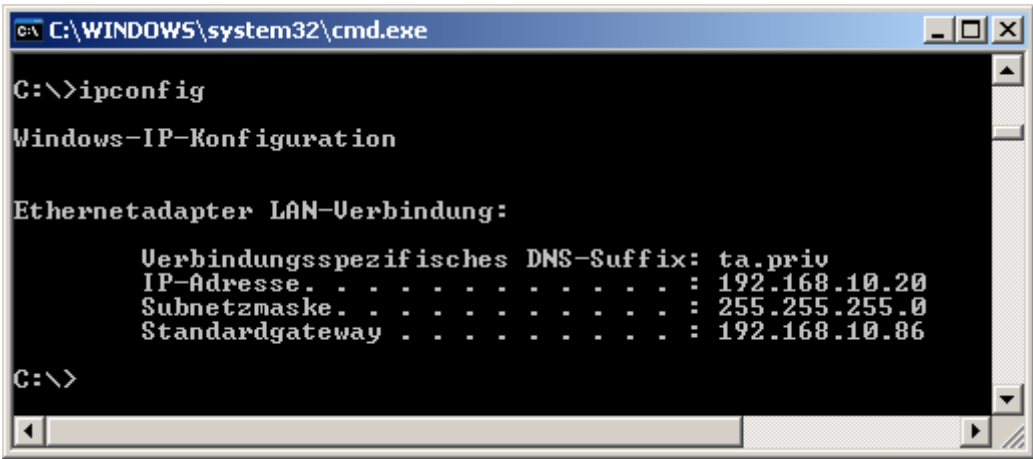

```
C:\WINDOWS\system32\cmd.exe
C:\>ipconfig

Windows-IP-Konfiguration

Ethernetadapter LAN-Verbindung:

    Verbindungsspezifisches DNS-Suffix: ta.priv
    IP-Adresse. . . . . : 192.168.10.20
    Subnetzmaske. . . . . : 255.255.255.0
    Standardgateway . . . . . : 192.168.10.86

C:\>
```

Note the IP address of the PC (e.g. 192.168.10.20) and the subnet mask of the LAN network (e.g. 255.255.255.0).

From the subnet mask and the IP address of the PC, it can be seen that all IP addresses in this network must begin with 192.168.10.xxx.

- The Bootloader must be assigned an IP address that does not yet exist in the network. The "**ping**" command in the command shell can be used to check if (e.g.): the desired IP address 192.168.10.**200** is free:

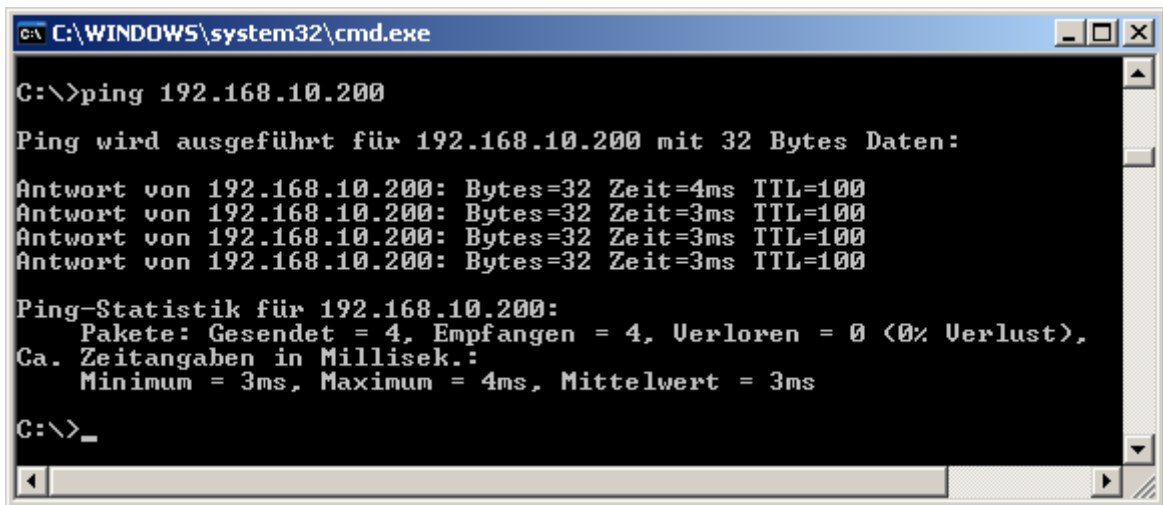

```
C:\WINDOWS\system32\cmd.exe
C:\>ping 192.168.10.200

Ping wird ausgeführt für 192.168.10.200 mit 32 Bytes Daten:

Antwort von 192.168.10.200: Bytes=32 Zeit=4ms TTL=100
Antwort von 192.168.10.200: Bytes=32 Zeit=3ms TTL=100
Antwort von 192.168.10.200: Bytes=32 Zeit=3ms TTL=100
Antwort von 192.168.10.200: Bytes=32 Zeit=3ms TTL=100

Ping-Statistik für 192.168.10.200:
    Pakete: Gesendet = 4, Empfangen = 4, Verloren = 0 (0% Verlust),
    Ca. Zeitangaben in Millisek.:
        Minimum = 3ms, Maximum = 4ms, Mittelwert = 3ms

C:\>_
```

Since the "**ping**" command above received an answer, the IP address 192.168.10.**200** is already assigned to a device in the network and cannot be used for the BL-NET. A new attempt with the IP address 192.168.10.**210** is therefore started:



```
C:\WINDOWS\system32\cmd.exe
C:\>ping 192.168.10.210

Ping wird ausgeführt für 192.168.10.210 mit 32 Bytes Daten:

Zeitüberschreitung der Anforderung.
Zeitüberschreitung der Anforderung.
Zeitüberschreitung der Anforderung.
Zeitüberschreitung der Anforderung.

Ping-Statistik für 192.168.10.210:
    Pakete: Gesendet = 4, Empfangen = 0, Verloren = 4 (100% Verlust),

C:\>
```

The IP address 192.168.10.**210** is not yet used (no answer to the "ping") and can thus be assigned to the BL-NET.

9. In the *Memory Manager*, the configuration of the BL-NET Ethernet interface is done in "SETUP" under "configure Bootloader" and in *Winsol* this form is located under (file → module → configure Bootloader):

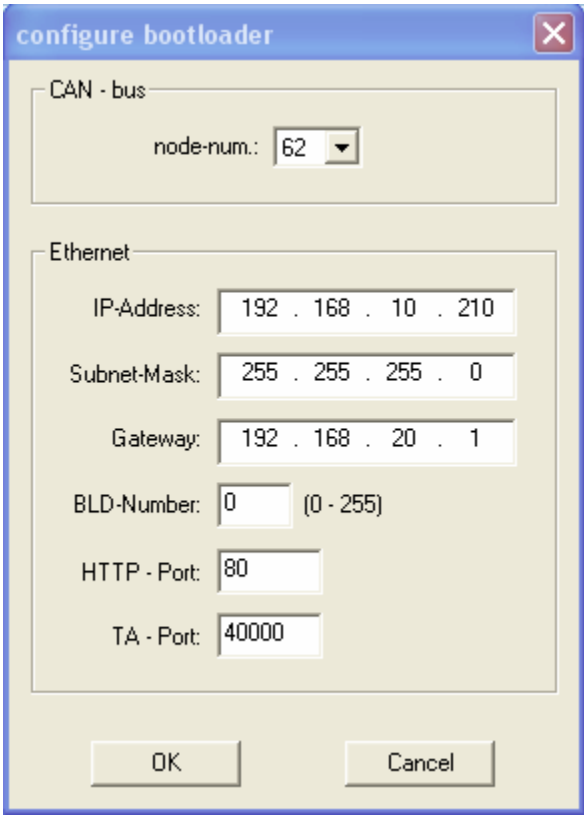

- IP address: The BL-NET is assigned the free IP address determined via "ping".
- Subnet mask: The subnet mask of the network determined via "ipconfig".
- Gateway: The gateway is currently not used.
- BLD number: If several Bootloaders are connected to the LAN network then each Bootloader must be assigned a different BLD number!
- HTTP port: The port used to access the Bootloader via a browser can be set to any desired value (default is port 80)
- TA port: Communication between *Winsol* and *Memory Manager* with the BL-NET occurs via this port. It is recommended to leave this port at the factory setting of 40000.

Clicking "OK" transfers the settings to the Bootloader and this restarts with the changed configuration (IP address, etc.).

10. The Bootloader is now correctly configured for the network and can be integrated into the network. **Note that the Ethernet interface of the BL-NET is only active when a CAN bus connection exists!**

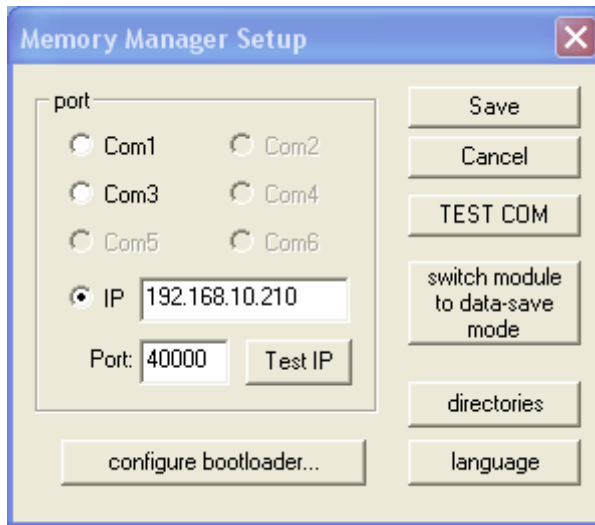

11. After the Bootloader has been prepared, the PC software must also be configured with the correct IP address and corresponding port. Point 9 describes configuration of the device only. Since several Bootloaders can be connected in a LAN network, this information must be specified again in the software (*Winsol* or *Memory Manager*) in order to address the correct BL-NET.

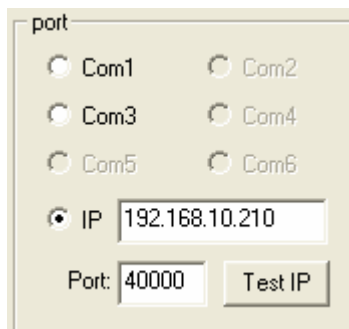

12. The Ethernet connection can then be checked via "**Test IP**". Access to the BL-NET via a browser (Opera, Internet Explorer, etc.) using the IP address is now possible, and thus also to the CAN network (UVR1611).



Accessing the BL-NET via a browser

Any browser (Internet Explorer, Mozilla Firefox, Opera, etc.) can be used to access the BL-NET. By using the back function of the browser, the last **displayed** page is made visible, which may possibly no longer be displaying the latest values. To ensure that the latest values are displayed, the page should be refreshed (Internet Explorer  , Mozilla Firefox  or: F5 key).

Accessing « **Hauptmenue** » (main menu) page

Entering the IP address of the BL-NET into any browser will display the BL-NET main page.

At present the BL-NET Bootloader operating system is only available in German! Therefore German terms are highlighted in yellow in this manual. In contrast to this, the language used to display the UVR1611 menus depends only on the language used in the controller operating system.

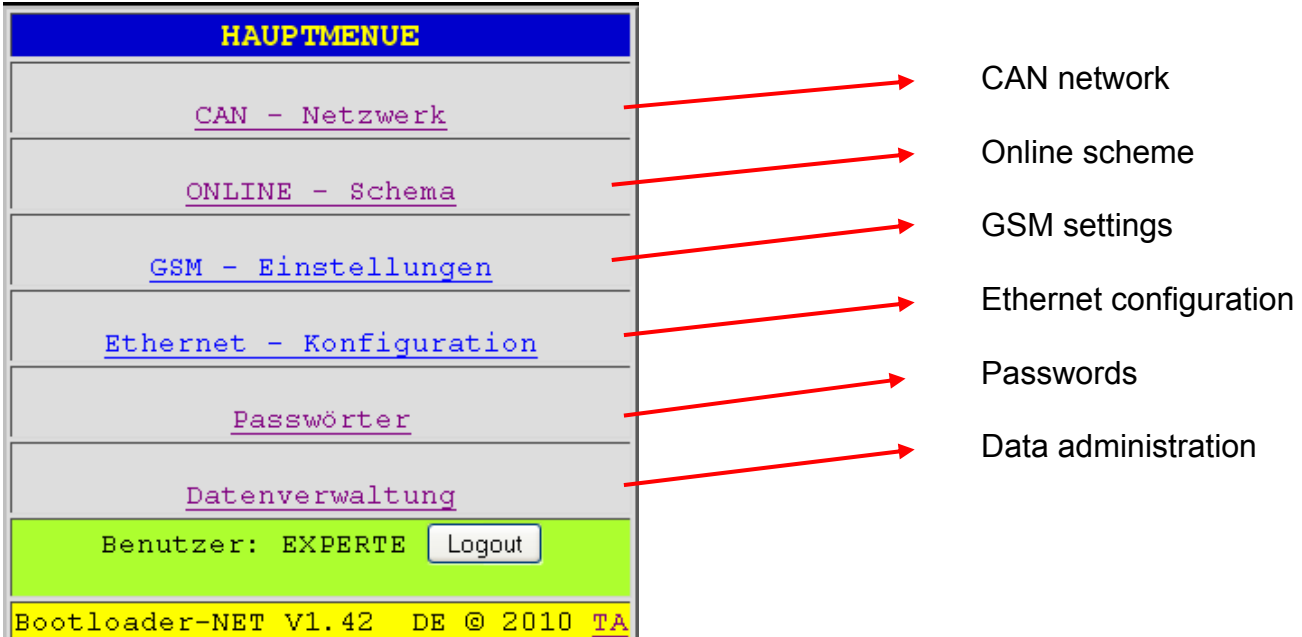

Menu Item	English Label
<u>CAN - Netzwerk</u>	CAN network
<u>ONLINE - Schema</u>	Online scheme
<u>GSM - Einstellungen</u>	GSM settings
<u>Ethernet - Konfiguration</u>	Ethernet configuration
<u>Passwörter</u>	Passwords
<u>Datenverwaltung</u>	Data administration

Every piece of underlined text is a link to another menu page that can be accessed by clicking the underlined text. The link "TA" at the bottom right opens the "Technische Alternative" homepage.

Menu overview:

"CAN - Netzwerk" (CAN network): The **"CAN - Netzwerk"** (CAN network) menu shows all active devices (nodes) connected to the Bootloader via the CAN bus. Selecting a node allows direct access to the menu pages of the node.

"Online - Schema" (online scheme): The Bootloader offers online visualisation, which provides a graphical representation of the current state of the system when viewed with a browser over the LAN or the Internet (see chapter „**Online Scheme**“).

"GSM - Einstellungen" (GSM settings): The status of BL-NET network inputs can be queried and the values for network outputs can be set via SMS. The **"GSM - Einstellungen"** (GSM settings) menu allows configuration of each of 16 analogue and 16 digital CAN network inputs/outputs of the BL-NET. Events can also be defined that cause the Bootloader to send an SMS when they occur. A GSM module is essential for all these functions.

"Ethernet – Konfiguration" (Ethernet configuration): The Ethernet settings can also be changed using a browser. However, since an Ethernet connection to the Bootloader must already exist, configuration of the Ethernet settings during **first-time commissioning** via USB interface is essential.

"Passwörter" (passwords): To prevent unauthorised external access (Internet, Intranet, etc.) the BL-NET has a password system. **To ensure protected and safe access via the Internet, additional safety precautions at the router are absolutely necessary.**

"Datenverwaltung" (data administration): The BL-NET Bootloader allows the transfer of functional data or operating systems to devices in the CAN network (UVR1611, CAN monitor and CAN-I/O module) over Ethernet using a browser.

Changing **"Passwörter"** (passwords)

Without passwords (factory setting) the system has no protection and anyone can access the BL-NET across the network. As soon as at least one **"Passwort"** (password) is defined, a login is required each time the BL-NET is accessed via Ethernet.

As with the UVR1611 controller, there are three possible **"Anwender"** (user groups) A, B and C, general **"Experte"** ("expert") access and **"nur ansehen"** ("read-only") access levels. All access levels are protected by their own **"Passwort"** (password). The password may contain a maximum of eight characters, with no special characters.

WARNING:

As long as no passwords have been defined, all persons knowing the IP address have unlimited access to the system, including all options for changing programs and settings!

Important: The first step must always be the definition of the expert password, since the system will not accept any other codes until this has been done. After entering the expert password, a user cannot access the system until a password has also been created for them.

Operating levels

"nur ansehen" ("read-only"): The user has limited access to pages and cannot make any changes. Important data such as telephone numbers, Ethernet settings or the password list cannot be viewed.

"Anwender A-C" ("user A-C"): Users A to C can access function overviews created for them in the controller and can edit parameters in these. The time can also be changed by these users.

"Experte" ("expert"): Expert users can change all parameters and settings.

If passwords have been defined then a login page is displayed for each access.

LOGIN

Experte

Anwender A

Anwender B

Anwender C

nur ansehen

Kennwort:

Bootloader-NET V1.38 DE © 2009 [TA](#)

Login is done using cookies, so your browser must be configured to accept cookies!

The corresponding password can only be entered after the desired entry level has been selected. An incorrect password causes the login page to be redisplayed. After entry of the correct password, the "**HAUPTMENUE**" (main menu) page is displayed.

Only one user can work on the Bootloader at any given time. If another user attempts to login at the same time the message "**Derzeit ist ein anderer Benutzer eingeloggt!**" ("Another user is currently logged in!") is displayed in his browser.

Derzeit ist ein anderer Benutzer eingeloggt!

Bootloader-NET V1.38 DE © 2009 [TA](#)

When work with the BL-NET is finished, it is recommended to end the session via the logout button. The session is automatically ended after five minutes without communication.

If the browser is closed without clicking the logout button, then no other login can occur for the next five minutes!

"CAN-Netzwerk" (CAN network)

The "**CAN - Netzwerk**" ("CAN network") menu shows all active devices (nodes) connected to the Bootloader via the CAN bus. Selecting a "**Knoten**" (node) and then executing the "**Menüseite laden**" ("load menu page") command allows direct access to the menu pages of the node.

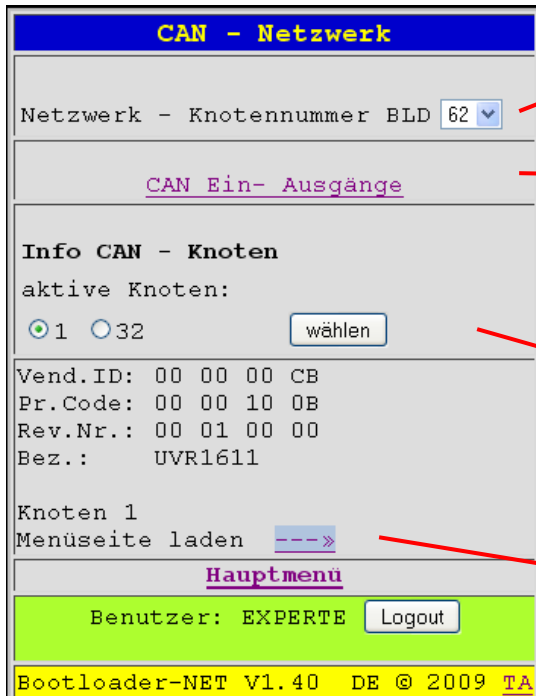

According to the illustration, the Bootloader is node 62 of the "**CAN-Netzwerk**" (CAN network).

Display or creation of the "**CAN Ein- und Ausgänge**" (CAN in- and outputs) of the Bootloader (see chapter "**GSM – Einstellungen/Abfragen**" (GSM-settings) or "**Befehle (commands)**")

Nodes 1, and 50 are also active in the network. "**Knoten**" (node) 1 is selected, in this case an UVR1611.

Select: Select the desired "**aktive Knoten**" (active node) and click the button.

The link button „**Menüseite laden**“ (load menu page) is used to access the nodes. The menu page of the device is then displayed.

UVR1611 menu page

The controller pages displayed in the browser are directly loaded from the controller and translated into HTML by the Bootloader. For larger pages, this can result in loading times of several seconds! Only the values current at the time of loading of the page that are displayed. In order to display the actual (latest) values, the page must be refreshed.

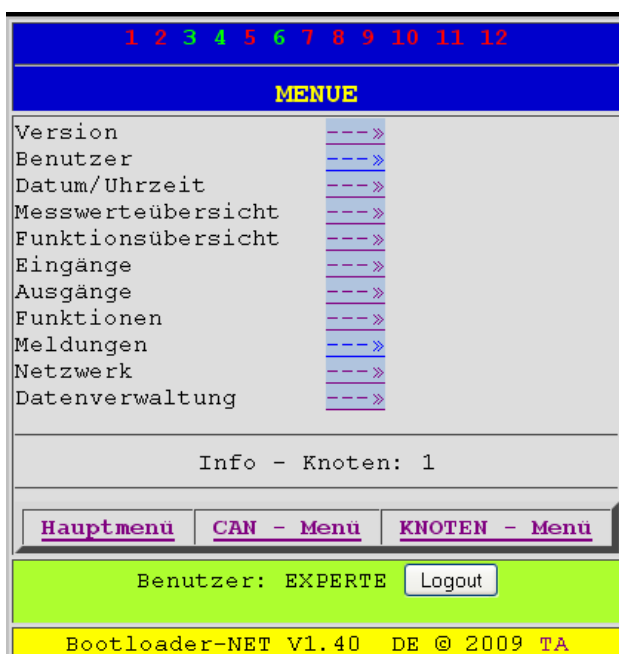

As with the controller, the top line shows the status of the outputs.

Green: Output on

Red: Output off

Addition H means "**Handbetrieb**" (manual operation).

Further navigation is done by clicking the link symbols . These buttons allow direct selection of the most important submenus. (Exception: menu "User").

Example: Parameterising input 1

1 2 3 4 5 6 7 8 9 10 11 12

EINGAENGE

1:	T.Kollektor	97,2 °C	PAR?	---	>
2:	T.Warmwasser1	66,1 °C	PAR?	---	>
3:	T.Warmwasser2	54,4 °C	PAR?	---	>
4:	T.SP.unten1	45,9 °C	PAR?	---	>
5:	T.SP.unten2	38,5 °C	PAR?	---	>
6:	T.SP.mitte	41,0 °C	PAR?	---	>
7:	T.SP.oben	54,8 °C	PAR?	---	>
8:	-----				
	unbenutzt		PAR?	---	>
9:	T.Kessel-VL	64,6 °C	PAR?	---	>
10:	T.Heizkr.VL1	48,4 °C	PAR?	---	>
11:	T.Heizkr.VL2	43,7 °C	PAR?	---	>
12:	Temp.Aussen	- 9,7 °C	PAR?	---	>
13:	Temp.Raum1	20,3 °C	PAR?	---	>
14:	Temp.Raum2	22,8 °C	PAR?	---	>
15:	-----				
	unbenutzt		PAR?	---	>
16:	-----				
	unbenutzt		PAR?	---	>

Info - Knoten: 1

Hauptmenü CAN - Menü KNOTEN - Menü

Benutzer: EXPERTE Logout

Bootloader-NET V1.40 DE © 2009 TA

After selection of the menu item "Inputs" this page is displayed, which has the same layout as in the controller.

By clicking the link symbol next to the desired input, the following display is brought up:

1 2 3 4 5 6 7 8 9 10 11 12

EINGANG 1

TYP: ANALOG <>

MESSGR.: Temperatur <>

BEZEICHNER-

GRUPPE: Allgemein <>

BEZ: T.Kollektor <>

SENSOR: KTY 10 <>

SENSORCHECK: nein <>

SENSORKORR.: 0,0 K <>

MITTELW.: 1,0 Sek <>

Info - Knoten: 1

Hauptmenü CAN - Menü KNOTEN - Menü

Benutzer: EXPERTE Logout

Bootloader-NET V1.40 DE © 2009 TA

Clicking the  button displays a selection list with the currently available settings parameters.

After selecting a value, this is immediately transferred to the controller via the CAN bus. The controller stores the parameter and then returns the corrected menu page, which is then redisplayed by the browser.

All editable parameters in the controller can be set using the method shown in the example. However no new functions can be created or deleted.

BL-NET "**Datenverwaltung**" (data administration) in „**Hauptmenü**“ (main menu)

The BL-NET Bootloader allows the transfer of functional data or operating systems to devices in the CAN network (UVR1611, CAN monitor and CAN-I/O module and bus converter CAN-BC) over Ethernet using a browser. In this case, additional preparation of the device for the data transfer is not necessary.

Page in browser:

Selection process:

Select ("**wählen**") the node with which the data transfer is to occur (NODE 63 is required for a new start if an operating system update was interrupted!)

Select the transfer direction of the functional data

Select the memory position of the "**Funktionsdaten**" (functional data) or "**Betriebssystem**" (operating system) (the name of the data is displayed next to the memory position number; the next row also displays the nodes from the stored functional data)

During a data upload (**Gerät** -> BL-NET) the data of the selected Bootloader storage location is overwritten, if any data was already stored there.

"**Transfer starten**" (start the transfer)

When the transfer is finished, the status of the transfer is automatically displayed in the browser ("**erfolgreich**" ("successful") or "**nicht erfolgreich**" ("unsuccessful")). Functional data takes about 45s to transfer and the operating system takes about 2min 40s.

Note that, after the transfer, the controller is restarted and the node is not visible at the BL-NET for about 20 seconds.

"GSM-Einstellungen" (GSM settings) in „Hauptmenue“ (main menu)

The status of the BL-NET network inputs can be queried via SMS. The values of the network outputs can also be set via SMS. The "**GSM-Einstellungen**" ("GSM-Settings") menu allows configuration of each of 16 analogue and 16 digital CAN network inputs/outputs of the BL-NET. Events can also be defined that cause the Bootloader to send an SMS or e-mail when they occur. A "**Telefonnummern Filter**" ("telephone numbers filter") can be used to ensure that the BL-NET only processes queries and commands from particular telephone numbers.

An integrated GSM module is required for all these functions and this module can be retrofitted if required.

GSM - Einstellungen

GSM - Empfangsleistung:

SMS Verarbeitung

Abfragen, Meldungen Analog

Abfragen, Meldungen Digital

Abfragen Gruppen

Befehle Analog

Befehle Digital

Telefonnummern

SMS Definitionen löschen

AUS SMS bei Knotenausfall senden?

AUS SMS bei Reset senden?

AUS Telefonnummern Filter?

Speichern

belegter Speicher Datenlogging: 4%

SMS bei 0 % Speicherauslastung senden!

Hauptmenü

Bootloader-NET V1.39 DE © 2009 TA

All settings for the GSM module and SMS communication can be made here.

If a GSM module is recognised, the "**Empfangsleistung**" (reception strength) is displayed as a bar.

Each of the 16 digital and analogue CAN network inputs/outputs of the Bootloader can be configured here for "**Abfragen**" (queries) and "**Meldungen**" (messages) or "**Befehle**" (commands) via SMS.

This button allows deletion of all SMS entries for the network inputs/outputs.

Appropriate warnings can be sent via SMS for particular events.

With an active number filter, only SMSs from numbers entered in the "**Telefonnummern**" ("telephone numbers") menu are processed.

Setting indicator at which level of used storage a (SMS) text message will be sent to prevent overflow of the storage. If setting "0" is selected, this function is deactivated.

"Telefonnummern" (telephone numbers)

Telefonnummern

Akzeptierte Telefonnummern:
mit Länderkennzahl beginnen z.B.: 0043...

1. Telefonnummer	<input type="text" value="00431234567890"/>	<input type="button" value="Speichern"/>
2. Telefonnummer	<input type="text"/>	<input type="button" value="Speichern"/>
3. Telefonnummer	<input type="text"/>	<input type="button" value="Speichern"/>

1. Telefonnummer wird auch für Mitteilungen von Ereignissen verwendet!

[Hauptmenü](#)

[zurück](#)

Bootloader-NET V1.38 DE © 2009 [TA](#)

With active telephone number filters, only queries from the numbers entered here are processed. In the example, one number ("**1. Telefonnummer**" (1st telephone number)) is entered. Events are sent only to the 1st telephone number.

"Abfragen" (queries) and "Meldungen" (messages) (analogue/digital)

The "**Abfragen, Meldungen Analog**" ("queries, messages analogue") and "**Abfragen, Meldungen Digital**" ("queries, messages digital") menus allow configuration of the CAN network inputs/outputs of the Bootloader, whose status can be queried via SMS. An optional "**Ereignis**" (event) can be defined for every network input, for which the BL-NET **automatically** sends an SMS.

Every network input of the BL-NET can be assigned to a particular "**Netzwerk-Ausgang**" (network output) of a device in the CAN network.

In the following example an UVR1611 (CAN node 1) sends the value of the measured tank temperature to the network via its analogue "**Netzwerk-Ausgang**" (network output) 3. This value is then read from the network by the BL-NET Bootloader via the analogue network input.

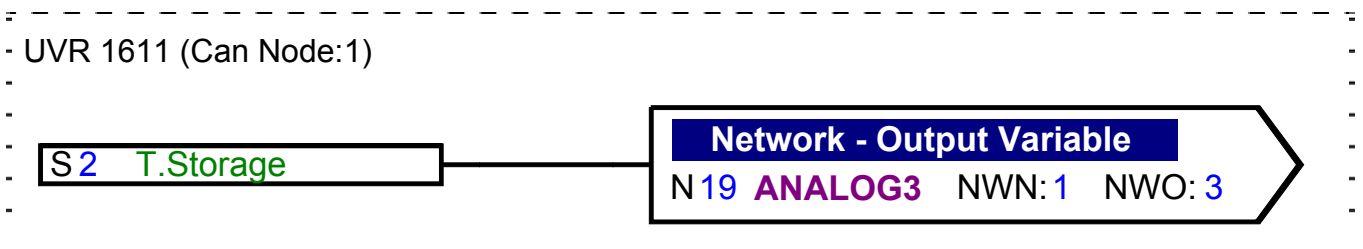

SMS for a query "Bezeichnung?" ("designation?")

Example: analogue input

Configuration of CAN "Analog Eingang" (analogue network input) 1:

„Bezeichnung“ (destination) „tank“
 „Netzwerknoten“ (network node) and „Netzwerkaustrag“ (network output) der „Quelle“ (source)
 „Ereignis“ (event) u. „Ereignistext“ (event text) for SMS,
 Confirm changes with the button **Speichern** (save)
 „aktueller Wert“ (current value): 74,8 °C

The current value can be queried with an SMS containing "tank?". An "Ereignis" (event) is also defined so that when the temperature drops below 20 °C an SMS containing " tank is cold " is sent to the first telephone number.

Example: Digital input

Configuration of CAN „Digital Eingang“ (digital network input) 1:

„Bezeichnung“ (destination) „load pump“
 „Netzwerknoten“ (network node) and „Netzwerkaustrag“ (network output) der „Quelle“ (source)
 „Ereignis“ (event) u. „Ereignistext“ (event text) for SMS,
 Confirm changes with the button **Speichern** (save)
 „aktueller Wert“ (current value): 0 (off)

The current value can be queried using an SMS (text) message "load pump?". Moreover an event is defined according to which the switching off of the pump causes an SMS text message "load pump OFF" to be sent to the first telephone number.

The event "H/L" means a state change from "ON" (=High or "1") to "OFF" (=Low or "0"), the result "L/H" a state change from "OFF" to "ON"

If an input is to be changed, the corresponding input number is entered and the desired entry modified. The CAN inputs and outputs can also be parameterised from the menu „CAN-Netzwerk“ (CAN network).

"Abfragen Gruppen" (group queries)

This menu allows the definition of groups in order to allow querying of entire blocks of data via a group designation, instead of just querying individual values.

When doing this, it is important to make sure that the 160 character limit of an SMS is not exceeded!

SMS for a group query: "Gruppenbezeichnung?" ("group designation?")

ABFRAGEN GRUPPEN

Abfragen GruppeNr.: 1

Bezeichnung für SMS: solar (max. 15 Zeichen)

analog Eingänge

1	tank
2	roomtemp
3	collector
4	outdoor temp
5	
6	
7	
8	
9	
10	
11	
12	
13	
14	
15	
16	

digital Eingänge

1	solar pump
2	load pump
3	
4	
5	
6	
7	
8	
9	
10	
11	
12	
13	
14	
15	
16	

134

1

Speichern

SMS: Bezeichnung?

Achtung: maximal 160 Zeichen für SMS möglich!

[Hauptmenü](#)

[zurück](#)

Bootloader-NET V1.39 DE © 2009 TA

Eight different groups can be defined.

Each group can contain a maximum of 8 values!

Definition is done in the entry line, with each respective number separated by a space. After storage the defined inputs are marked blue.

In the example, the SMS "solar?" can be used to query the values of analogue network inputs 1, 3 and 4, and digital network input 1.

"Befehle" (commands) (analogue/digital)

The "**Befehle Analog**" ("analogue commands") and "**Befehle Digital**" ("digital commands") menus allow the configuration of Bootloader CAN network outputs so that their values can be set via SMS.

A **digital network output** is set using the values "**ON**" or "**OFF**", whereby upper/lower case makes no difference (e.g. SMS "Enable:on!").

SMS (text message) as digital command: „designation:value!“ = heat circ:on!

The screenshot shows the 'BEFEHLE DIGITAL' menu. At the top, it says 'Digital Ausgang Nr.: 1' with a dropdown arrow. Below that is a text input field for 'Bezeichnung für SMS' containing the word 'Enable', with '(max. 15 Zeichen)' to its right. A 'Speichern' button is located to the right of the input field. Below the input field, it displays 'SMS: Bezeichnung:on(off)!' in a monospaced font. The menu has several navigation options: 'CAN Ein- Ausgänge', 'GSM - Einstellungen', and 'Hauptmenü', each underlined. At the bottom, it shows 'Benutzer: EXPERTE' and a 'Logout' button. The footer of the menu reads 'Bootloader-NET V1.42 DE © 2010 TA'.

As confirmation an SMS (text) message with the content "**Enable = on**" is received. An **analogue network output** is set using a value without a decimal separator (e.g.: 250 for 25.0°C) (e.g. SMS: Heating:250).

SMS (text message) as digital command: „designation:value!“ = heating:250!

The screenshot shows the 'BEFEHLE ANALOG' menu. At the top, it says 'Analog Ausgang Nr.: 1' with a dropdown arrow. Below that is a text input field for 'Bezeichnung für SMS' containing the word 'heating', with '(max. 15 Zeichen)' to its right. A 'Speichern' button is located to the right of the input field. Below the input field, it displays 'SMS: Bezeichnung:250!' in a monospaced font. Below that, it shows '(entweder Wert ohne Komma, 'Standby', 'Zeit', 'Normal', 'Abgesenkt' oder 'intern')'. The menu has several navigation options: 'CAN Ein- Ausgänge', 'GSM - Einstellungen', and 'Hauptmenü', each underlined. At the bottom, it shows 'Benutzer: EXPERTE' and a 'Logout' button. The footer of the menu reads 'Bootloader-NET V1.39 DE © 2009 TA'.

As confirmation an SMS (text) message with the content "**Heating = 250**" is received. The network outputs defined in this way can also be transferred into the programming of the UVR 1611 as network inputs.

In addition, the commands "Standby", "Zeit" ("time"), "Normal", "Abgesenkt" ("reduced") and "intern" ("internal") can be used to change the operating mode of a heating circuit via SMS. The bootloader forwards these commands to the CAN network as **analog** numbers. To do this, the corresponding parameterised **analogue** network input of the UVR1611 must be linked to the "External Switch" input of the heating circuit control function (see UVR1611 operating instructions, *Function module "Heating circuit controller"/external switch*):

UVR1611 (Example: programming for the SMS (text) heating command: "Standby", "Time", "Normal", "Lowered" and "Internal")

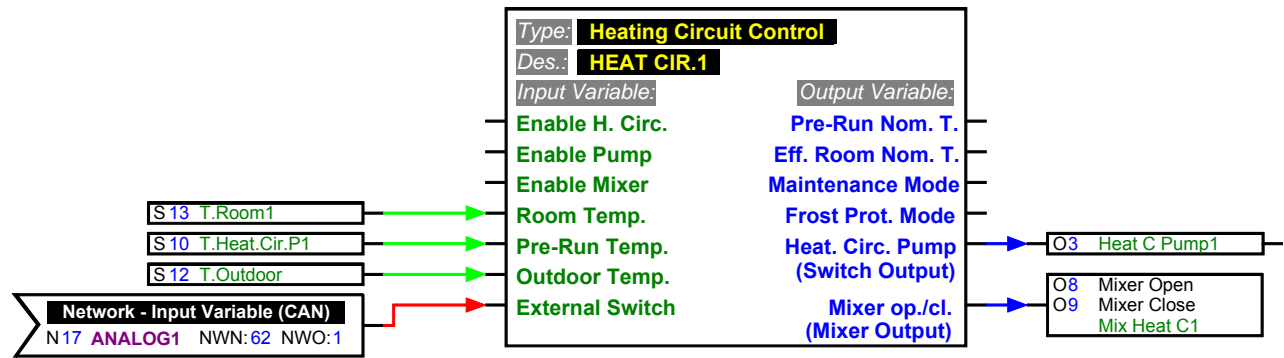

In the above example, the "Analog Ausgang" (analogue network output) 1 is assigned the designation "heating". With an SMS containing "heating:Abgesenkt!" ("=heating:reduced!") the heating circuit switches to the reduction mode, whereas the SMS "heating:intern!" ("=heating:internal!") causes the internal operating state of the controller to be used. As confirmation of the command an SMS (text) message with the content "Heating = Lowered" is received.

To ensure safety, the Bootloader forwards this command to the controller three times at intervals of 5 minutes. After 15 minutes have elapsed, the operating mode can again be manually changed (e.g. on the RAS room sensor, on the CAN monitor, on the controller itself or via a browser).

Values output by analog commands with text input:

Text input	Value <u>within</u> the first 15 minutes from SMS receipt	Value <u>after</u> the first 15 minutes from SMS receipt
Standby	64	0
Time	65	1
Normal	66	2
Lowered	67	3
Internal	127	63

After 15 minutes the Bootloader sends a value from the second column (0 - 63), dependent on the text input. This value does not cause any further changes in the heating circuit controller.

After resetting of the Bootloader after the 15 minutes, the Bootloader likewise sends the value from the second column (0 - 63).

WARNING! If during these 15 minutes a manual change to the operating mode is made, then the controller does indeed "notice" this change, however it only acts on it, once the SMS (text) command "Heating:internal!" is issued. If during this time an operating mode **other** than "RAS" is selected then, once the 15 minutes elapses, this operating mode cannot be changed on the **RAS**, rather only on the controller, on the CAN monitor or via the browser.

"Ethernet – Konfiguration" (Ethernet configuration)

The Ethernet settings can also be changed using a browser. However, since an Ethernet connection to the Bootloader must already exist, configuration of the Ethernet settings via the USB interface during first-time commissioning is recommended. **See also the section "Connecting the BL-NET to a LAN network"**

Ethernet – Konfiguration	
IP - Adresse:	<input type="text" value="192.168.10.100"/> <input type="button" value="Speichern"/>
Subnet - Mask:	<input type="text" value="255.255.255.0"/> <input type="button" value="Speichern"/>
Gateway:	<input type="text" value="192.168.0.1"/> <input type="button" value="Speichern"/>
BLD - Nummer:	<input type="text" value="0"/> 0-255 <input type="button" value="Speichern"/>
Aktualisieren der Werte durch Neustart! <input type="button" value="Neustart"/>	
Hauptmenü	
Bootloader-NET V1.38 DE © 2009 TA	

Changes do not take effect until the "**Neustart**" (restart) of the BL-NET!!!

NOTE: The commonly used subnet mask of 255.255.255.0 means that when an IP address is assigned where the first three numbers are not the same as the internal network (here 192.168.10.xxx) or the assigned IP address is already used by another device in the network, then the Bootloader can no longer be accessed within this network. New parameterisation of the Ethernet connection via a USB connection is required before normal Ethernet access is possible once more.

Data transfer BL-NET ↔ UVR1611

Selection of the interface for the data transfer

CAN bus line

To transfer the data via CAN, all four CAN conductors (H, L, +, ⊥) must be connected. The battery is unimportant here.

Key to CAN symbols: H.....CAN high
 L.....CAN low
 +.....+12 volt
 ⊥.....Mass

Infrared interface

A cable is not required for infrared transfer, only a 9V battery is required. The infrared interface is primarily intended for service purposes. It is recommended that this only be used for transferring functional data! An operating system download requires the Bootloader to be held motionless on the controller for several minutes (**if this is not successful, transfers can then only be done using a cable!**)



Position of the BL-NET on the controller for infrared transfers:

- Upper edge of the BL-NET lies at the lower edge of the UVR display
- Display side edges are marked with → | **DISPLAYPOSITION UVR1611** | ← on the BL-NET

NODE 63:

Data transfer of the operating system and functional data is always performed by the Bootloader using node 63 of the CAN network.

This special node number is used exclusively for these data transfers and must not be assigned to any device in the CAN network.

The device waiting for data transfer with the Bootloader automatically uses node number 63 for this period of time.

Data transfer procedure

The device that is to exchange data with the Bootloader must be prepared for the data transfer. Once the device is ready for communication, the data transfer is started by pressing the START button on the BL-NET.

When the START button is pressed, the green LED on the front of the BL-NET begins to flash rapidly. This indicates that the BL-NET is attempting to establish communication with the controller (no data is transferred at this point!).

If the red LED lights up cyclically during an infrared transfer then the battery voltage has reached a critical level and the battery must be replaced as soon as possible.

Functional data download (BL => UVR1611)

Data down- and upload to and from the controller are started at the controller. The Bootloader has 7 memory positions for functional data. These can be written with data from the controller or functional data from the PC (using the *Memory Manager* program). The functional data upload differs only in the selection of the transfer direction (CONTR. => BOOTLD.) and is not described here in detail.

Controller view	Comment
<pre> MENU ----- : Data Administration ◀ </pre>	<p>Select Data Administration in the main menu of the UVR1611 controller</p>
<pre> DATA ADMINISTRATION ----- : DATA <=> BOOTLOADER: Upload Data: CONTR. => BOOTLD. Download Data: BOOTLD. => CONTR. ◀ </pre>	<p>select: Download Data: BOOTLD. => CONTR.</p>
<pre> BOOTLD. => CONTR. ----- DATA SOURCE: BOOTLD. Storage Point: 1 ◀ TARGET: Contr. Funct. Data Overwrite? yes Factory Settings Overwrite? no : DOWNLOAD DATA REALLY START? yes ◀ </pre>	<p>Select the desired storage point for the functional data at the BL-NET</p> <p>Overwrite the controller functional data?</p> <p>Adopt the functional data as the factory setting?</p> <p>The controller switches to transfer mode</p>
<pre> NODE: 63 READY FOR DOWNLOAD ABORT </pre>	<p>The controller is ready for the data transfer. When the START button on the Bootloader is pressed, the green LED begins flashing rapidly and the data transfer starts.</p> <p>ABORT = Last option for cancelling the data transfer (press right key)</p>
<pre> NODE: 63 1: Functional Data XXX PROGRAMMING 000700 / 007FB0 </pre>	<p>The transfer is running</p> <p>Name of the functional data</p> <p>Progress display</p>
<pre> NODE: 63 SUCCESSFUL DOWNLOAD </pre>	<p>The functional data was successfully loaded into the controller.</p>

Operating system download (BL ⇒ UVR1611)

The latest operating system versions can be downloaded from the homepage at www.ta.co.at. The Bootloader can only manage one operating system. This download contains the boot sector and operating system for the controller. The boot sector can be compared with the BIOS on a PC. The boot sector can also change for technical reasons. In this case, when updating an operating system the boot sector is loaded first and the download of the actual operating system is then automatically started after this. If the boot sector is the same then only the new operating system is loaded.

Controller view	Comment
<pre> MENU ----- : Data Administration ◀ </pre>	<p>Select Data Administration in the main menu of the UVR1611 controller</p>
<pre> DATA ADMINISTRATION ----- : OPER.SYSTEM<=BOOTLD.: Download Oper.System: BOOTLD. => CONTR. ◀ </pre>	<p>select: Download Oper.System: BOOTLD. => CONTR.</p>
<pre> BOOTLD. => CONTR. ----- DOWNL. OPERAT.SYSTEM REALLY START? yes ◀ WARNING: Use Cable Wiring </pre>	<p>The controller switches to transfer mode</p> <p>A cable connection should normally be used for transferring the operating system!</p>
<pre> NODE: 63 READY FOR DOWNLOAD ABORT </pre>	<p>The controller is ready for the data transfer. When the START button on the Bootloader is pressed, the green LED begins flashing rapidly and the data transfer starts.</p> <p>ABORT = Last option for cancelling the data transfer (press right key)</p>
<pre> NODE: 63 PROGRAMMING 005400/ 020000 </pre>	<p>The transfer is running.</p> <p>Progress display</p>
<pre> NODE: 63 SUCCESSFUL DOWNLOAD </pre>	<p>The data was successfully transferred to the controller</p>
<pre> TECHN. ALTERNATIVE ----- Homepage: www.ta.co.at ----- UVR1611 Operat.Syst.: Ax.xx Bootsector: Bx.xx </pre>	<p>Note: if the boot sector and operating system are updated the steps 4 to 6 are repeated without the START button being pressed again</p> <p>After the operating system update is finished, the start page is displayed on the controller.</p>

Data transfer via Ethernet using a browser

With the BL-NET it is also possible to start the data transfer using any desired web browser. A precondition for this is that an Ethernet connection has already been set up (see chapter "BL-NET data administration").

Procedure:

- a) Select "**Datenverwaltung**" (data administration) in the BL-NET "**Hauptmenue**" (main menu)
- b) Select the node (the controller with which communication is to occur)
- c) Select the transfer direction
- d) Select the data (functional data or operating system)
- e) Start the transfer

When the transfer is finished, an appropriate message is displayed in the browser ("**erfolgreich**" ("successful") or "**nicht erfolgreich**" ("unsuccessful")).

Troubleshooting data transfers

Operating system download (BL → UVR)

If an error occurs when transferring the operating system, after an automatic restart the controller continues to wait as "**NODE 63**" for the operating system data transfer to begin again ("**READY FOR DOWNLOAD**"). As long as the operating system has not been fully loaded into the UVR1611, the controller has no other functionality.

Pressing the START button on the Bootloader starts the data transfer again.

If the data transfer is done via Ethernet using a browser, the "**NODE 63**" button can be used to directly start the transfer with node 63.

Functional data download (BL → UVR)

If an error occurs when downloading functional data, the controller automatically performs a total reset of the configuration. The "**Knoten-Nr.**" ("node No."), "**Freigabe**" ("enable") and "Autooperat." network settings are not changed.

The data transfer of the functional data must be performed again.

WARNING! If a transfer fault occurs in a network with multiple devices, a data transfer to a different device must not be started until the fault is fixed!

In general, an operating system should only be updated when functions that are only contained in the newer operating system are required (Never change a running system!). Similar to PC BIOS updates, an operating system update always represents a certain small risk.

"Online-Schema" (online scheme)

The Bootloader offers online visualisation that provides a graphical representation of the current state of the system when viewed with a browser over the LAN or the Internet.

This online scheme consists of a graphic file (e.g. hydraulic schematic) and the associated HTML file defining the parameters to be displayed.

The files (*.gif and *.html) can be stored in the Bootloader using the *Memory Manager* program (see chapter "**Transfer of Bootloader data**").

Creating a graphic for the online scheme

The graphic can be created using any desired graphics or drawing program, or with *TAPPS*, whereby the following points should be observed:

1. The graphic must be provided to the BL-NET in *.gif format. (For creation of the online scheme in *TAPPS* the same graphic in *.bmp format is required). Conversion of the file into the various formats can be simply carried out using the Windows accessories program "Paint".
2. The file must not exceed the maximum size of 196 kilobytes! To reduce the loading time when displaying the online scheme, the graphic file should be kept as small as possible.

Creating the HTML file

A HTML file containing all information defining the appearance of the page is required for displaying the online scheme.

The HTML file can be easily created using the *TAPPS* program. *TAPPS* creates the required HTML file based on graphical positioning and assignment of the values to be displayed. The exact procedure is described in the *TAPPS* operating manual.

The HTML file must not exceed the maximum size of 196 kilobytes and should be kept as small as possible to reduce the loading time!

Definition of display values

The syntax for defining a displayed value is as follows:

Identifier for the definition of a displayed value

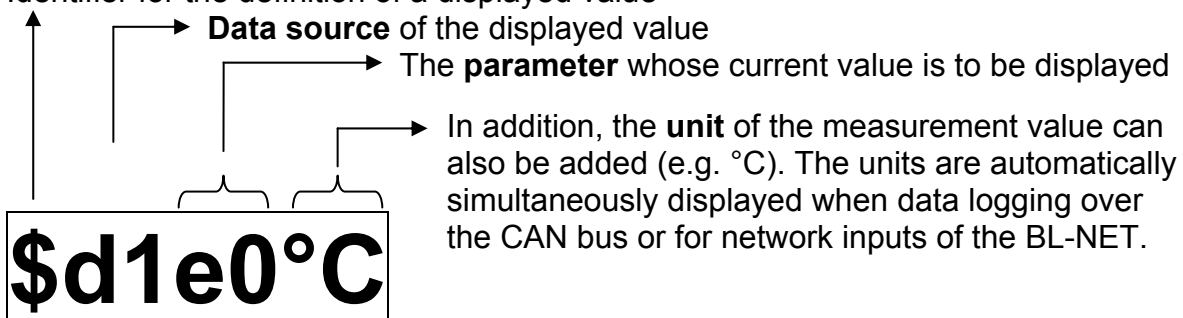

The definition of a displayed value always begins with the "\$" character, followed by the definition of the *data source* and the *parameter* whose current value is to be displayed.

The definitions are replaced with corresponding current measurements when BL-NET displays the online scheme. The current (latest) values are displayed upon calling the online scheme and, upon changing or refreshing the page.

If no measurements are available, "**NO-DL**" is displayed in the online scheme. An invalid definition causes "**ERROR**" to be displayed.

Data source:

d1	...	DL bus 1
d2	...	DL bus 2
n1	...	CAN network inputs of the BL-NET
c1...c8	...	CAN data logging

Parameter:

Data logging using the DL-bus:

Depending on the device type of the controller to be acquired, the following parameters are available for visualisation:

Input:	e0...ef	(Inputs 1...16)
Output:	a0...ac	(Outputs 1...13)
Speed setting:	d1, d2, d6, d7	(Speed setting for output 1, 2, 6 or 7)
Power:	l1, l2	(kW of heat meter 1 or 2)
kWh:	k1, k2	(kWh of heat meter 1 or 2)
MWh:	m1, m2	(MWh of heat meter 1 or 2)
Date:	t1	
Time:	z1	

CAN data logging:

The following parameters are available for visualisation:

The selection of the controller whose data is to be displayed (can be set by selecting a controller data frame) and

Analogue values of the first data record	a0...af	Sensors 1...16
Analogue values of the second data record	A0...Af	Sensors 1...16
Digital values of the first data record	d0...dc	Output 1...13
Digital values of the second data record	D0...Dc	Output 1...13

Example of a definition of a display value from the CAN data logging:

► **c4**: Data from each controller, to which data frame **4** relates, are displayed.

\$c4Ae

► **Analogue** value of the **second** data record

► Sensor 15 (see „hexadecimal table“)

BL-NET CAN network inputs:

In addition to the values obtained from data logging over DL or CAN buses, the values at the network inputs of the BL-NET can also be displayed. The network inputs can be defined using a browser in the „**CAN Netzwerk/CAN Ein- Ausgänge**“ (CAN network/ CAN in-outputs) menu or „**GSM-Einstellungen**“ (“GSM settings”) menu of the BL-NET (see the relevant chapter).

Analogue input: a0...af (Analogue network inputs 1...16)
Digital input: d0...df (Digital network inputs 1...16)

NOTE: The inputs and outputs are **numbered from zero in hexadecimal** (see hexadecimal table)!
Consequently, for example when data logging over the DL-bus, the definition "e0" results for input 1 and for input 16 the definition "eF".

Hexadecimal table:

dez	0	1	2	3	4	5	6	7	8	9	10	11	12	13	14	15
hex	0	1	2	3	4	5	6	7	8	9	a	b	c	d	e	f
Def	1	2	3	4	5	6	7	8	9	10	11	12	13	14	15	16

Examples:

\$d1ef ... DL bus 1, input 16 of the controller
\$d2a0 ... DL bus 2, output 1 of the controller
\$n1a1 ... Network, analogue network input 2 of the Bootloader
\$c1da ... Can data logging, Controller of the frame 1, digital value (output) 11 of the dataframe 1
\$c2A1 ... Can data logging, Controller of the frame 1, analogue value (sensor) 1 of the dataframe 2

Factory settings

To load the BL-NET factory settings, the battery must first be removed and, when the CAN bus connection is plugged in, the START button on the Bootloader must be pressed and held pressed until only the green LED lights up.

The factory settings include the following parameters:

CAN bus:

Node No.: 62

Ethernet:

MAC-adress 02 50 C2 5C 60 xx

IP address: 192.168.0.1

Subnet mask: 255.255.255.0

Gateway: 192.168.0.1

BLD - No.: 0

HTTP port: 80

TA port: 40000

Passwords:

Expert no password specified

“Anwender A” (user A) no password specified

“Anwender B” (user B) no password specified

“Anwender C” (user C) no password specified

“nur ansehen”

(read only) no password specified

Guarantee conditions

Note: The following guarantee conditions do not in any way limit the legal right to a guarantee, rather expand your rights as a consumer.

1. The company Technische Alternative elektronische Steuerungsgesellschaft m. b. H. provides a two-year guarantee from the date of purchase by the end consumer for all the devices and parts which it sells. Defects must be reported immediately upon detection and within the guarantee period. Technical support knows the correct solution for nearly all problems. In this respect, contacting us immediately will help to avoid unnecessary expense or effort in troubleshooting.
2. The guarantee includes the free of charge repair (but not the cost of on site fault-finding, removal, refitting and shipping) of operational and material defects which impair operation. In the event that a repair is not, for reasons of cost, worthwhile according to the assessment of Technische Alternative, the goods will be replaced.
3. Not included is damage resulting from the effects of overvoltages or abnormal ambient conditions. Likewise, no guarantee liability can be accepted if the device defect is due to: transport damage for which we are not responsible, incorrect installation and assembly, incorrect use, non-observance of operating and installation instructions or incorrect maintenance.
4. The guarantee claim will expire if repairs or actions are carried out by persons who are not authorised to do so or have not been so authorised by us or if our devices are operated with spare, supplementary or accessory parts which are not considered to be original parts.
5. The defective parts must be sent to our factory with an enclosed copy of the proof of purchase and a precise description of the defect. A filled in "service advice note", which can be downloaded from our homepage www.ta.co.at, will accelerate processing. A prior clarification of the defect with our technical support is necessary.
6. Services provided under guarantee result neither in an extension of the guarantee period nor in a resetting of the guarantee period. The guarantee period for fitted parts ends with the guarantee period of the whole device.
7. Extended or other claims, especially those for compensation for damage other than to the device itself are, insofar as a liability is not legally required, excluded.

Technische Alternative elektronische Steuerungsgerätegesellschaft m.b.H.

A-3872 Amaliendorf Langestraße 124

Tel ++43 (0)2862 53635

Fax ++43 (0)2862 53635 7

E-Mail: mail@ta.co.at

--- www.ta.co.at ---

© 2010