

ESR 31

Version 1.8-3 EN

Simple solar control unit



Operation
Installation instructions

EN



TECHNISCHE
ALTERNATIVE

This instruction manual is available in English at www.ta.co.at

Diese Anleitung ist im Internet auch in Deutsch unter www.ta.co.at verfügbar.

Ce manuel d'instructions est disponible en langue française sur le site Internet
www.ta.co.at

Questo manuale d'istruzioni è disponibile in italiano sul sito Internet
www.ta.co.at

Estas instrucciones de funcionamiento están disponibles en español, en
Internet www.ta.co.at.

Table of contents

Generally applicable rules.....	5
Stagnation.....	5
Safety requirements:.....	6
Maintenance.....	6
Hydraulic diagrams.....	7
Solar thermal system - program 0 - 2	7
Loading pump control - program 4 - 6	8
Air flap control for an earth collector - program 8 - 9	9
Burner requirement using holding circuit - program 12.....	10
Preparation of hot water – program 16, 17, 18 (only for speed version ESR31-D).....	10
Operation:.....	12
The main level:.....	13
Changing a value (parameter) :.....	15
The parameter menu PAR	16
Set values (Thresholds and differential values).....	17
Automatic / manual mode of output O AUTO	19
Automatic / manual mode of control output C AUTO	19
The menu MEN	20
Sensor menu SENSOR :.....	21
System protection functions SYS PF :.....	24
Collector excess temperature CET :	25
Collector anti-freeze FROST :.....	25
Start function STARTF (ideal for tube collectors)	26
After-running time ART :.....	27
Pump speed control PSC : (only ESR31-D)	28
Absolute value control.....	30
Differential control.....	31
Event control.....	32
Waveform	32
Stability problems.....	33
Pump standstill	34
Control commands.....	34
Control output COP 0-10 V / PWM:.....	35
Function check F CHCK :.....	37
Heat quantity counter HQC	38
External sensors EXT DL :	44
Status display Status	45
Installation instructions.....	47
Sensor installation:.....	47
Cable laying	47
Installing the device	48
Electrical connection.....	48
Data link (DL-Bus).....	48
Tips on troubleshooting.....	49
Table of settings:.....	50
Technical data.....	52

Generally applicable rules for the correct use of this control unit:

The manufacturer of the control unit cannot be held liable for any indirect damage to the system if the party that installs the system does not install any additional electromechanical devices (thermostat, possibly in combination with a one-way valve) to protect the system from damage as a result of a malfunction under the following conditions:

- ◆ Solar thermal system for swimming pools: An excess temperature thermostat and a self-actuating one-way valve (normally closed) must be installed in the supply line in combination with a high-performance collector and heat-sensitive system components (such as plastic lines). The valve can also be supplied from the control unit's pump outlet. Thus, all of the heat-sensitive parts are protected from excess temperature if the system is at standstill, even if steam (stagnation) occurs in the system. This arrangement is prescribed in particular for systems with heat exchangers as a failure of the secondary pump would otherwise cause great damage to the plastic tubes.
- ◆ Conventional solar thermal systems with external heat exchangers: in such systems, the secondary heat transfer medium is usually pure water. If the pump runs at temperatures below freezing because the control unit has failed, there is a danger of the heat exchanger and other parts of the system being damaged by frost. In this case, a thermostat has to be installed directly after the heat exchanger on the supply line of the secondary side to switch off the primary pump automatically if the temperature drops below 5°C regardless of the control unit's output.
- ◆ In combination with floor and wall heaters: here, a safety thermostat is prescribed as with conventional control units for heaters. It must switch off the heating circulation pump to prevent indirect damage due to excess temperature regardless of the output of the control unit.

Stagnation- Solar thermal systems - tips for system standstill:

In principle, stagnation is not a problem and cannot be ruled out, for instance due to a blackout. In summer, the limited storage capacity of the control unit can cause the system to shut down repeatedly. A system thus always has to be intrinsically safe. This safety is ensured if the expansion tank has the proper dimensions. Tests have shown that the heat transfer medium (antifreeze) is under less stress during stagnation than shortly before the steam phase.

The data sheets of all collector manufacturers have standstill temperatures above 200°C, but these temperatures generally only occur in the operating phase with "dry steam", i.e. when the heat transfer medium in the collector has completely evaporated or when the steam has completely emptied the collector. The humid steam dehumidifies quickly and loses its heat conductivity. Thus, it can be generally assumed that these high temperatures cannot occur at the measuring point of the collector sensor (if installed in the collecting tube as usual) as the remaining thermal line cools down the medium with its metal connections from the absorber to the sensor.

Safety requirements:



All installation and wiring work on the controller must only be carried out in a zero-volts state.

The opening, connection and commissioning of the device may only be carried out by competent personnel. In so doing, all local security requirements must be adhered to.

The device corresponds to the latest state of the art and fulfils all necessary safety conditions. It may only be used or deployed in accordance with the technical data and the safety conditions and rules listed below. When using the device, the legal and safety regulations apposite to the particular use are also to be observed.

- ▶ The device must only be installed in a dry interior room.
- ▶ It must be possible to isolate the controller from the mains using an all-pole isolating device (plug/socket or double pole isolator).
- ▶ Before starting installation or wiring work, the controller must be completely isolated from the mains voltage and protected against being switched back on. Never interchange the safety extra-low voltage connections (sensor connections) with the 230V connections. Destructive and life-threatening voltages at the device and the connected sensors may occur.
- ▶ Solar thermal systems can become very hot. Consequently there is a risk of burns. Take care when fitting temperature sensors!
- ▶ For safety reasons, the system should only be left in manual mode when testing. In this operating mode, no maximum temperatures or sensor functions are monitored.
- ▶ Safe operation is no longer possible if the controller or connected equipment exhibits visual damage, no longer functions or has been stored for a lengthy period of time under unsuitable conditions. If this is the case, place the controller and equipment out of service and secure against unintentional use.

Maintenance

If used properly, the system does not require maintenance. A cloth moistened with a soft alcohol (such as spirit) should be used for cleaning. Harsh solvents such as chlorethenes or tri-gases are not admissible.

As the components relevant to accuracy are not subjected to loads if used properly, long-term deviation is very low. The unit thus cannot be adjusted. Hence, no calibration is possible. The construction characteristics of the unit must not be changed for repairs. Spare parts must correspond to the original parts and be used as intended.

Hydraulic diagrams

Solar thermal system - program 0 = factory settings

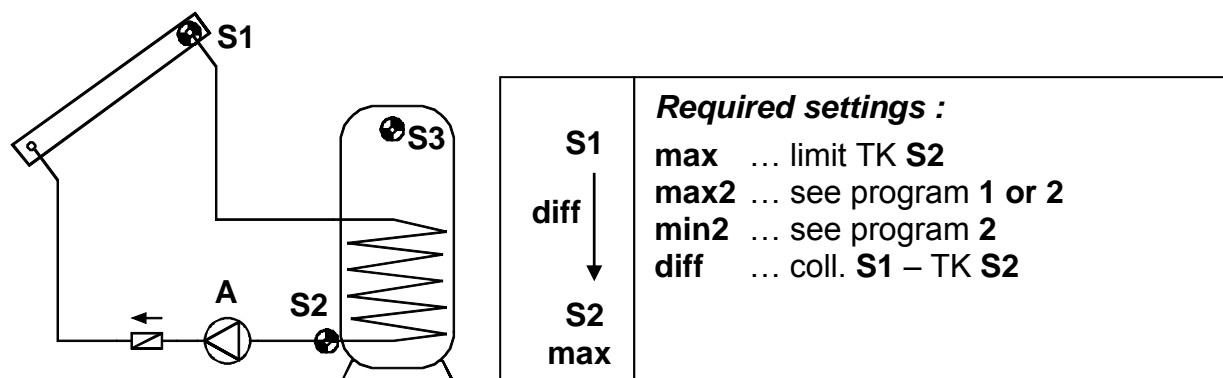

The solar pump **A** runs when **S1** has a temperature of **diff** higher than **S2** and **S2** has not exceeded the threshold **max**.

In addition, the pump's protective function takes effect: During a standstill, steam can occur in the system. When automatically switched on again, the pump does not have the required pressure in the steam phase to lift the fluid level to the collector's supply line (highest point in the system). This represents a considerable load on the pump. The collector's excess temperature shut-down function can be used to block the pump whenever a certain temperature has been reached at the collector's sensor until a second threshold, which can also be set, is fallen short of again. The settings ex works are 130°C for the blockage and 110°C for the release. The settings can be changed in the menu **MEN**, sub-menu **SYS PF/CET** (collector excess temperature).

Program 1:

With this program, the solar thermal system has an additional storage limit **max2** via sensor **S3**. There is no guarantee that the actual storage temperature will lead to a cut-off in time, especially if the reference sensor **S2** is installed at the return outlet for the heat exchanger.

Program 2:

As program 0, however with additional 10 V burner requirement via **S3** at control output.

Additional required settings:

max2↓ ... COP off (0V) **S3** (ex works = 65°C)

min2↑ ... COP on (10V) **S3** (ex works = 40°C)

A = **S1** > (**S2** + **diff**) & **S2** < **max**

Control output COP: 10 V = **S3** < **min2** (burner on)

0 V = **S3** > **max2** (burner off)

Subsequently, an auxiliary relay can be connected to the control output HIREL31-STAG, which forwards the burner requirement in potential-free format. The active control output is indicated by the flashing burner symbol in the display.

Note:

In programs 0 - 2, the system condition "Collector - excess temperature reached" is indicated in the menu Δ Status by the advice **CETOFF** for **Collector Excess Temperature switch off**. Some countries only offer subsidies for the installation of solar thermal systems if the control units have a function check to detect a sensor defect and a lack of circulation. In the menu command **F CHCK**, the mechanic can activate this function check for the ESR31. It applies likewise for this program and is deactivated in the factory settings. For details, see "Status display Δ Status".

Loading pump control - program 4

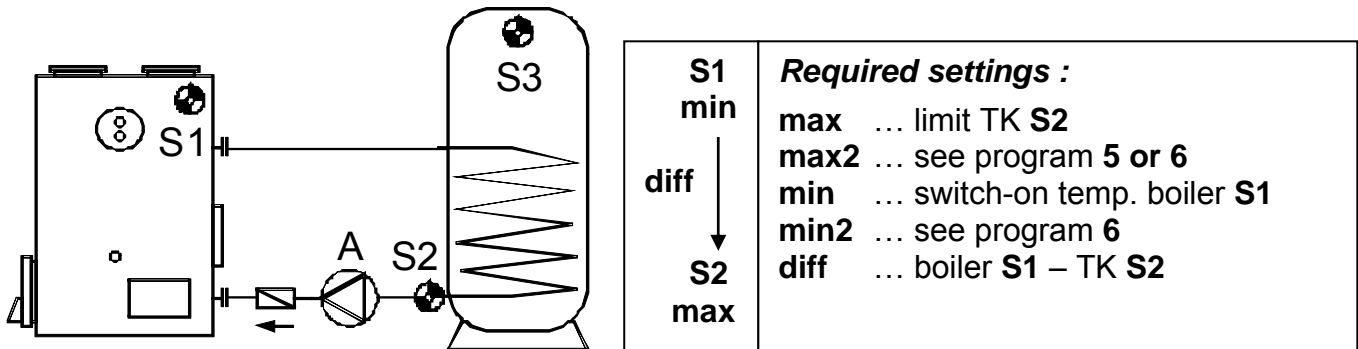

The loading pump **A** runs when **S1** has exceeded the threshold **min**, the temperature of **S1** is **diff** higher than **S2**, and **S2** has not yet crossed the threshold **max**.

Program 5

The loading pump function has an additional storage limiter **max2** via sensor **S3**.

Program 6:

As program 4, however with additional 10 V burner requirement via **S3** and **S2** at control output.

Additional required settings:	
max2 ↓ ... COP off (0V)	S2 (ex works = 65°C)
min2 ↑ ... COP on (10V)	S3 (ex works = 40°C)

A = S1 > min & S1 > (S2 + diff) & S2 < max
Control output COP: 10 V = S3 < min2 (burner on)
0 V = S2 > max2 (burner off)

Subsequently, an auxiliary relay can be connected to the control output HIREL31-STAG, which forwards the burner requirement in potential-free format. The active control output is indicated by the flashing burner symbol in the display.

Program 7

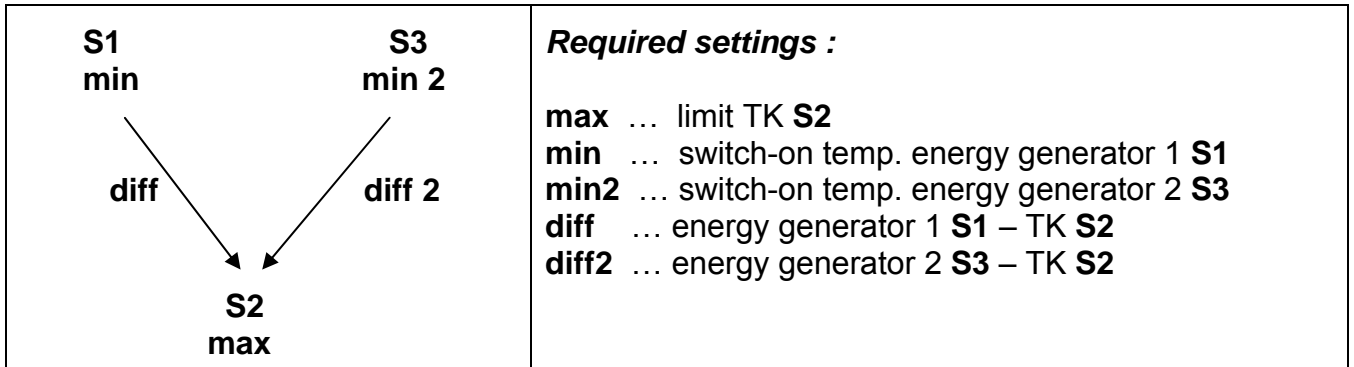

The loading pump function has an additional threshold **min2** via sensor S3 and temperature difference **diff2** between S3 and S2. Hence, the system can be switched off via two energy generators (S1 and/or S3).

Air flap control for an earth collector - program 8

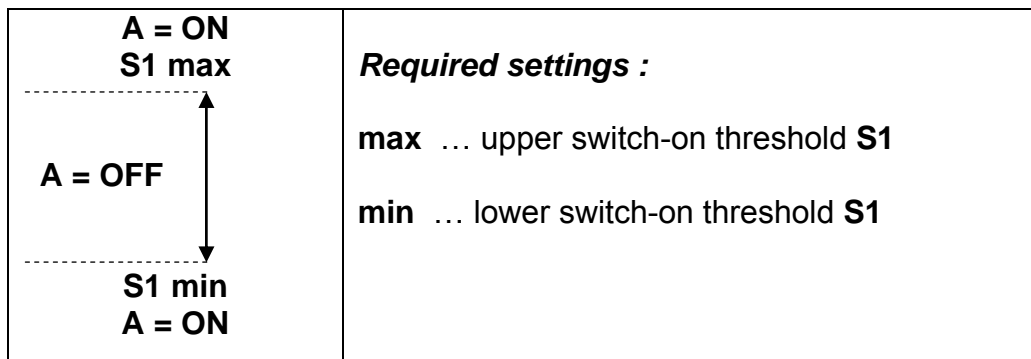

The output switches when $S1 > \mathbf{max}$ or $< \mathbf{min}$. An air/water heat pump thus has a flap for the airflow from the earth collector above the outside ambient temperature **max** (regeneration) and below the outside ambient temperature **min** (heating). S2 and S3 have no function.

Program 9

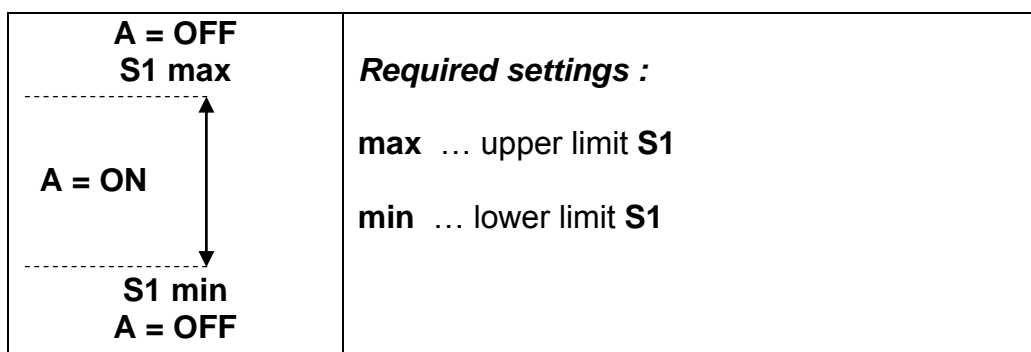

The output switches when $S1 < \mathbf{max}$ and $> \mathbf{min}$. Hence, while program 8 switches above and below a temperature window, program 9 switches within a temperature window.

Burner requirement using holding circuit - program 12

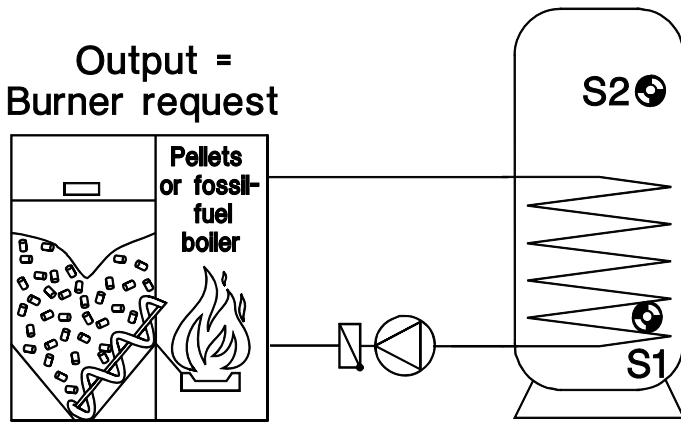

Required settings :

max↓ ... limit **S1**
(ex works = 65°C)

min↑ ... switch-on threshold **S2**
(ex works = 40°C)

The output switches on when **S2 < min↑** and only switches off when **S1 > max↓**. In other words, boiler requirement when S2 falls short of **min↑** in the upper storage area and switch-off when S1 exceeds **max↓** in the lower part of the tank. **The output terminal is not potential-free.**

Preparation of hot water – program 16, 17, 18 (only for speed version ESR31-D)

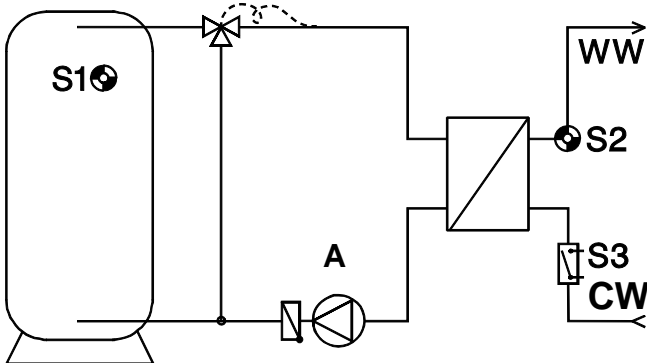

Required settings :

DVA ... desired value for **absolute** value control **S2**

DVD ... desired value for **differential** control **S1–S2**

Program 17: Setting of sensor 3 as a digital input in the menu **MEN/Sensor**

Program 18: setting of sensor **S2** as VTS (vortex temperature sensor) and sensor **S3** as VF2 (vortex volume flow encoder) in the menu **MEN/Sensor**

Menu PAR: min threshold of the flow in l/h
(ex works = 5 l/h)

possible other settings in the **PSC**-menu (PRO/INT/DIF/MIN/MAX)

Diagram for program 16 without flow switch S3

Diagram for program 17 with flow switch S3

Generally for all programs (16, 17, 18):

No thermostat function or differential switching function is activated. Calling one of these two programs the measuring speed of the input S2 is automatically increased from AV 1.0 to AV 0.4 (see in the menu **MEN** under **SENSOR**) and the speed control is activated as an alternative parameter list with the following **factory settings**(see in the menu **MEN** under **PSC**):

Abs. value control AC..... I 2	Desired value DVA..... 48 °C	
Differential control DC.. N12	Desired value DVD..... 7.0 K	
Event control EC..... ---		
Proportional part PRO.... 3	Integral part INT..... 1	Differential part DIF..... 4
Minimum speed MIN..... 0	Maximum speed MAX... 30	Delay time ALV 0

In addition, the set values for the desired hot water temperature (**DVA**) and the mixing difference (**DVD**) is put down in the parameter menu to provide the user with quick access.

For more detailed data related to speed process and stability see: Pump speed control **PSC**.

Program 16 (only for speed version ESR31-D)

By using the speed control the heat exchange outlet can be kept permanently at a constant temperature via the **ultrafast sensor** S2 (non-standard accessory). Low stand-by losses may occur. A volume flow switch S3 is not necessary.

Program 17 (only for speed version ESR31-D)

The speed control is only activated, if the volume flow switch S3 (non-standard accessory) indicates a flow. Very few stand-by losses may occur. When starting, the system is a little lazier and a volume flow switch is necessary.

Program 18 (only for speed version ESR31-D)

Speed control is only active if the volume flow at sensor S3 (VFS2-40) exceeds the minimum flow rate, **min**. Temperature sensor S2 is the VFS2-40 temperature sensor.

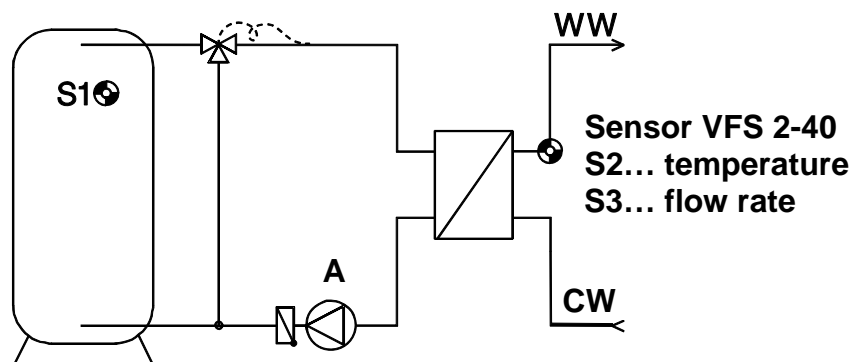

Additional required settings: Setting of sensor **S2** as VTS (vortex temperature sensor) and sensor **S3** as VF2 (vortex volume flow encoder) in the menu **MEN/Sensor**
Menu PAR: min threshold of the flow in l/h (ex works = 5 l/h)

Operation:

The large display contains all of the icons for all of the important information and a field for plain text. Navigation with the co-ordination keys is adapted to the display structure.

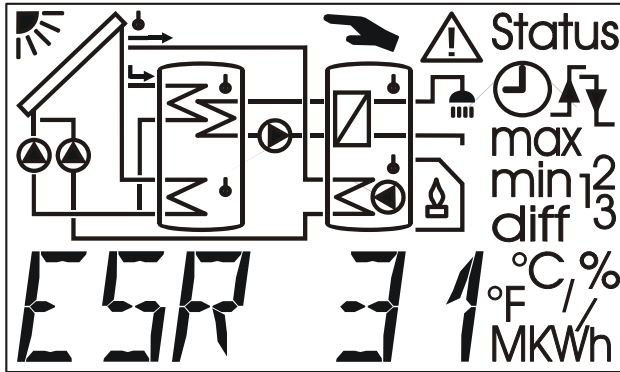

↔ = Navigation keys to select the display and change parameters.

↓ = Enter a menu, release a value to change using the navigation keys.

↑ = Return to the last menu level selected, exit the setting of parameters for a value.

In the main level, the left/right arrows ↔ are the navigation keys to select the desired display, such as collector or storage tank temperature. A different sensor symbol flashes for each pressure and the corresponding temperature is displayed.

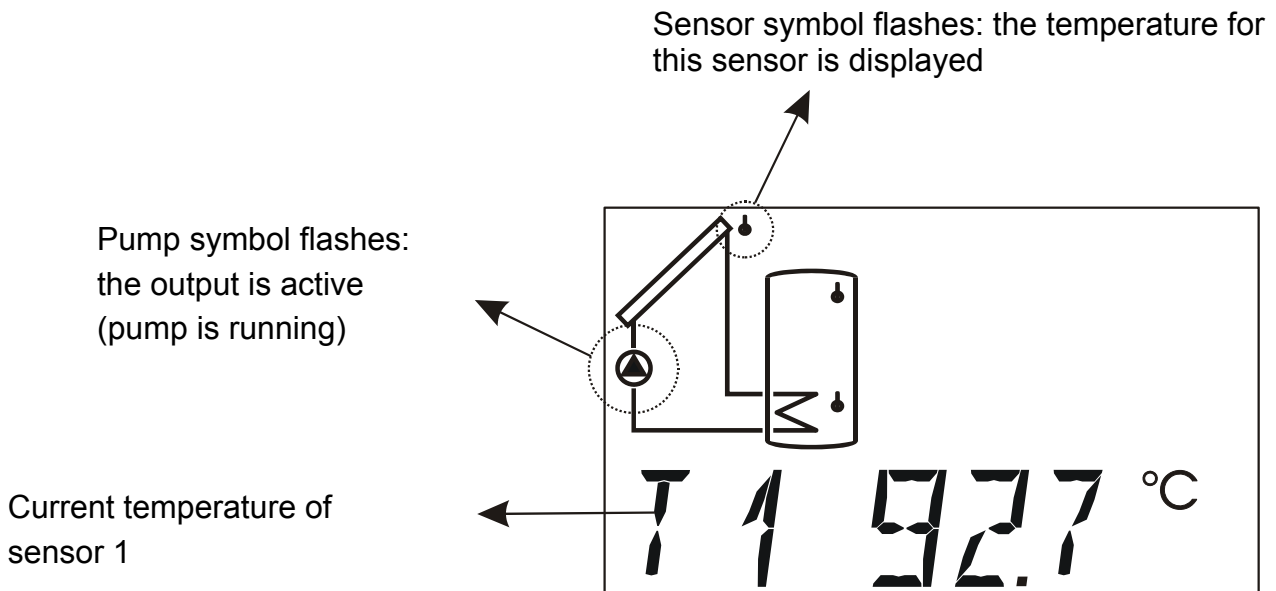

The main level:

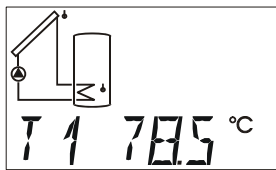

Temperature Sensor 1

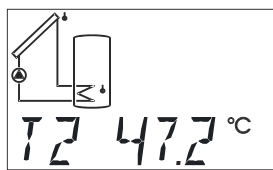

Temperature Sensor 2

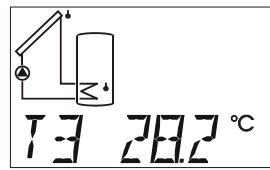

Temperature Sensor 3

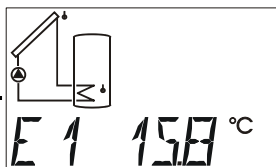

External value 1
Only displayed if external DL is activated

...

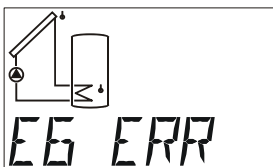

External value 6
Only displayed if external DL is activated

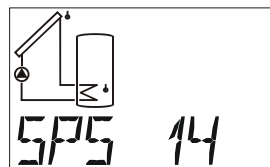

Speed stage
ESR31-D only and active PSC

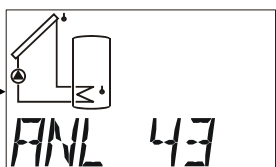

Analogue stage only if control output activated

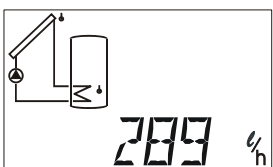

Volume flow only displayed if heat counter is activated

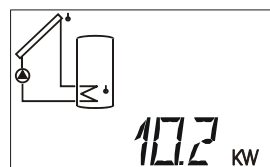

Current power only displayed if heat counter is activated

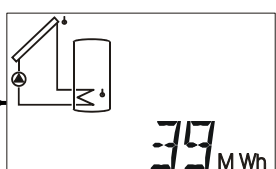

MWh only displayed if heat counter is activated

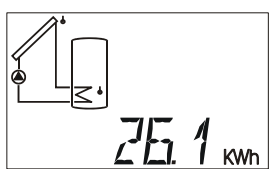

kWh only displayed if heat counter is activated

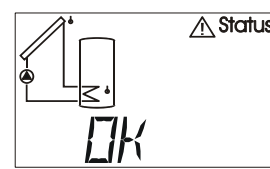

Status display "OK" only displays if active function control

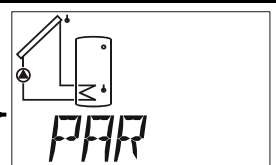

Parameter menu **PAR**

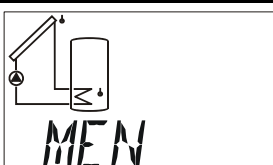

Menu **MEN**

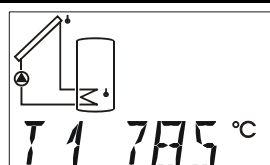

Temperature Sensor 1

...

- T1 to T3** Displays the value measured at the sensor (S1 - T1, S2 - T2, S3 – T3).
- E1 to E6** Displays the values from external sensors which are read via the DL-bus. Only activated inputs are displayed.
ERR means that no valid value has been read. In this case the external value is set to 0.
- SPS** Speed stage (only ESR31-D), indicates the current speed stage. This menu item is only displayed if the speed control is activated.
 Display range: 0 = output is off
 30 = speed control is running at the highest stage
- ANL** Analogue level indicates the current analogue level of the 0-10V output - only displayed if the 0-10V output control system has been activated.
 Display range: 0 = output voltage = 0V or 0% (PWM)
 100 = output voltage = 10V or 100% (PWM)
- l/h** The volume flow, indicates the flow rate of the volume flow encoder (only possible to input 3), or the volume flow rate of an external sensor via DL, or the fixed volume flow in litres per hour.
- kW** The current output of the heat counter indicated in kW.
- MWh** Megawatt hours, indicates the megawatt hours of the heat counter.
- kWh** Kilowatt-hours, indicates the kilowatt-hours of the heat counter.
 When 1000 kWh have been reached the counter restarts at 0 and the MWh are increased by 1.
- Menu items **l/h**, **kW**, **MWh**, and **kWh** are only displayed if the heat counter has been activated.
- ⚠Status:** Display of the system's status. Depending on the program selected, various system statuses are monitored. If any problems have occurred, this menu contains all of the information.
- PAR:** The navigation keys on the parameter level (←, →) allow you to select the icons under the temperature display and the text line. The parameter selected can now be released for selection with the down key ↓ (enter). The parameter blinks to indicate release. Press one of the navigation keys to change the value by one increment. Keep the key pressed to keep the value running. The changed value is adopted when the UP key ↑ (return) is pressed. To prevent unintended changes in parameters, entry in **PAR** is only possible using the **code 32**.
- MEN:** The menu contains basic settings to determine additional functions such as the sensor type, language, the system protection functions, etc. Use the keys for navigation and to make changes as usual. The dialogue is only set up via the text line. As the settings in the menu change the basic features of the control unit, entry is only possible with a code that only the technician knows.

The settings of the parameters and menu functions ex works can be restored at any time using the down key (entry) when plugging the unit in. If this occurs, WELOAD will appear in the display for three seconds.

Warning! All parameters and menu points already set will be deleted.

Further sensor display types:

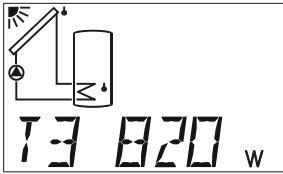

Radiation in W/m²
(radiation sensor)

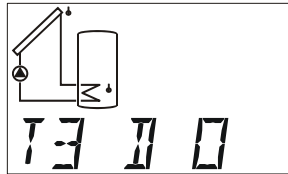

Digital state
(0=OFF, 1=ON)
(digital input)

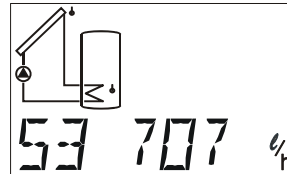

Flow in l/h (sensor
3 = VFS 2-40)

If in the **SENSOR** menu (main menu **MEN**) one sensor is set to **OFF** or a volume flow encoder **VSG** is defined, then the value display of this sensor is hidden at the main level.

Changing a value (parameter) :

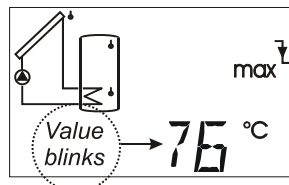
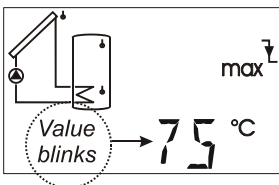
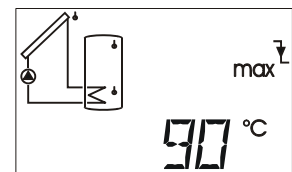
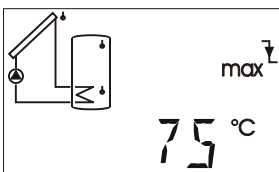

...

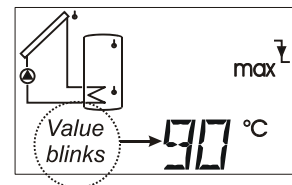

If a value is to be changed, press the down arrow key. This value will then blink and can be set to the desired value with the navigation keys. Use the arrow key up to save the value.

The parameter menu *PAR*

(Version number, program number, min, max, diff, auto/manual mode)

In the following example the **PAR** menu has been selected for program 5 so that all setting parameters (max2, min) can be displayed.

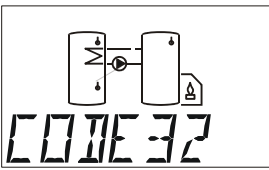
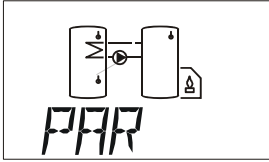

Code to enter menu

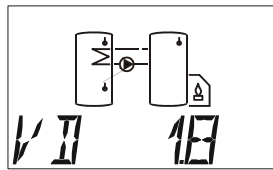

Version number

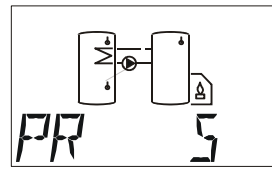

Program number

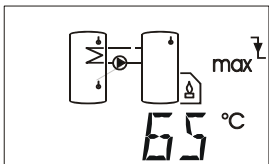

Max limit switch-off threshold

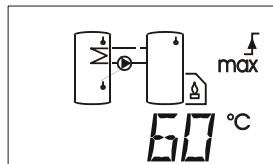

Max limit switch-on threshold

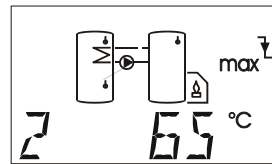

Max2 limit switch-off threshold

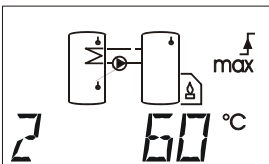

Max2 limit switch-on threshold

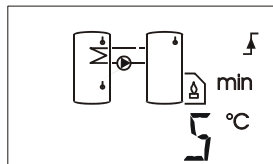

Min limit switch-on threshold

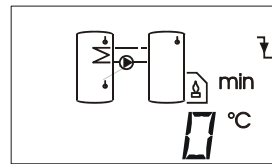

Min limit switch-off threshold

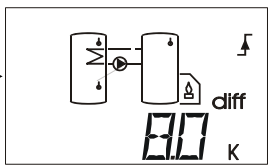

Difference switch-on threshold

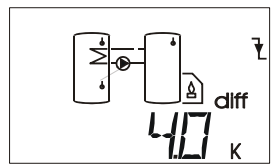

Difference switch-off threshold

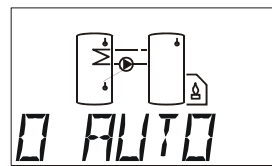

Automatic / Manual mode output

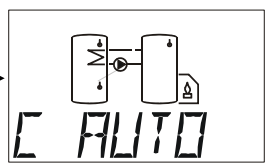

Automatic / Manual mode control output

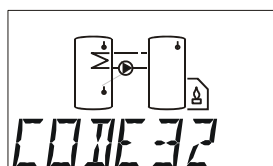

...

Once the parameter menu has been opened (using the **code 32**), the following tips and setting options appear depending on the program selected:

VD 1.8 Software version of the device (**VR** = version with relay output, **VD** = speed version). It cannot be changed as it indicates the intelligence of the device and must be provided if there are any queries.

PR Selection of the appropriate **program** according to the selected diagram. For a solar thermal system, that would be the number 0 or 1.

Set values (Thresholds and differential values)

The device does not have any switching differentials (difference between temperatures to switch on or off); rather, all of the threshold values are divided into switch-on and switch-off values. In addition, some programs have several similar thresholds such as **max**, **max2**. To make a distinction, the index for max is also displayed in the left parameter line.

CAUTION: When setting the parameter, the computer always limits the threshold value (such as **max on**↑) when it approaches a certain temperature of the second threshold (such as **max off**↓) to prevent negative hysteresis. If a threshold cannot be changed any longer, the second threshold has to be changed first.

max ↓ When this temperature has been reached, the output is blocked (ex works = 65°C).

max ↑ The output blocked at **max** ↓ is released again when this temperature has been reached. **max** generally serves to limit storage. Recommendation: The switch-off point should be some 3-5K higher than the switch-on point in the storage area and some 1-2K higher than in the pool area. The software does not allow for differences less than 1K (ex works = 60°C).

Setting range: -30 to +149°C in increments of 1°C (for both thresholds, but **max**↓ has to be at least 1K greater than **max**↑)

min ↑ When this temperature has been reached at the sensor, the output is released (display only with the corresponding program diagram) (ex works = 5°C).

min ↓ The output previously released via **min** ↑ is blocked again when this temperature has been reached. **min** generally protects the boilers from soot. Recommendation: The switch-on point should be some 3-5K higher than the switch-off point. The software does not allow for differences less than 1K (ex works = 0°C).

Setting range: -30 to +149°C in increments of 1°C (for both thresholds, but **min**↑ has to be at least 1K greater than **min**↓)

diff ↑ If the temperature difference between the two set sensors surpasses this value, the output is released. For most programs, **diff** is the basic function (differential controller) of the system. Recommendation: For solar applications, **diff** ↑ should be set to around 7-10K (factory settings WE = 8K). Slightly lower values suffice for the loading pump program (ex works = 8K).

diff ↓ The output previously released when **diff** ↑ was reached is blocked again when this temperature difference is reached. Recommendation: **diff** ↓ should be set to around 3-5K (WE = 4K). Although the software allows for a minimum difference of 0.1K between the switch-on and switch-off points, no value less than 2K can be entered for sensor and measurement tolerance (ex works = 4K).

Setting range: 0.0 to 9.9K in increments of 0.1K

10 to 98K in increments of 1K (for both thresholds, but **diff**↑ has to be at least 0.1K / 1K greater than **diff**↓)

Schematic representation of setting values

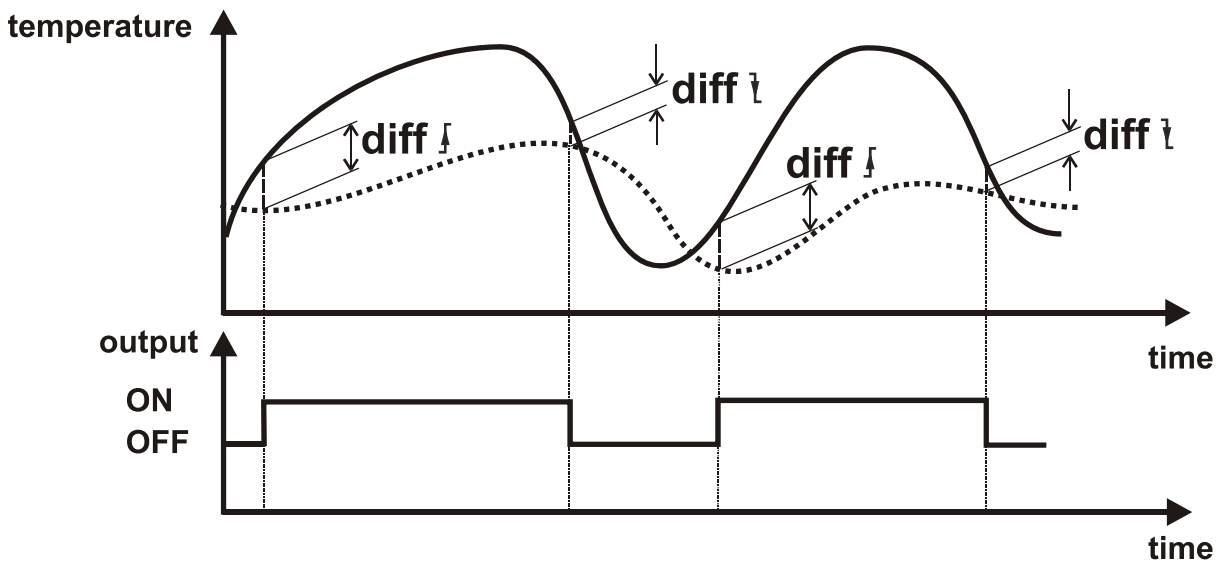
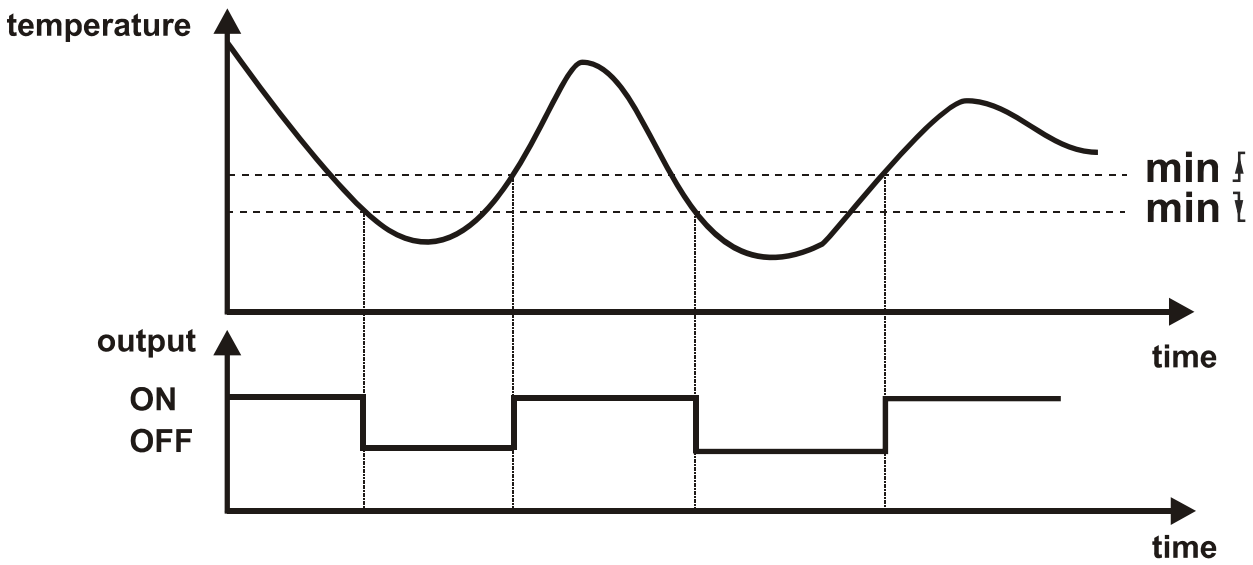
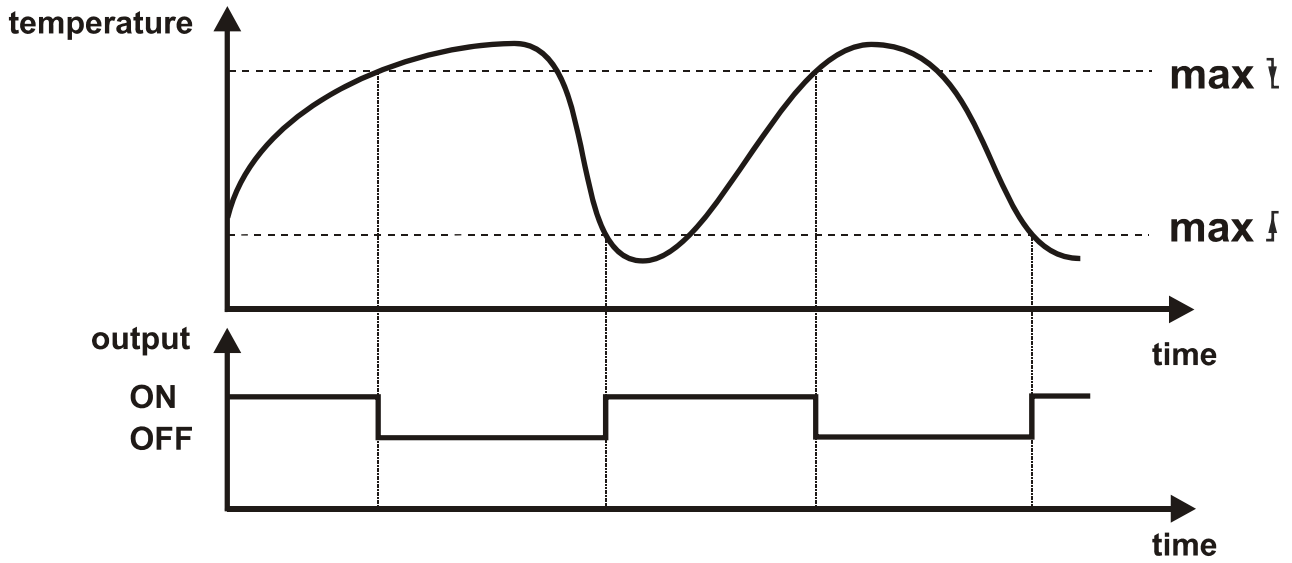

O AUTO The output is set to automatic mode and can be switched for test purposes to manual mode (**O ON**, **O OFF**). When the manual mode has been selected, an icon appears at the top. **If the hand symbol is displayed, the control function is deactivated.** (ex works = AUTO)

Settings: **AUTO** the output switches according to the program diagram
ON the output switches on
OFF the output switches off

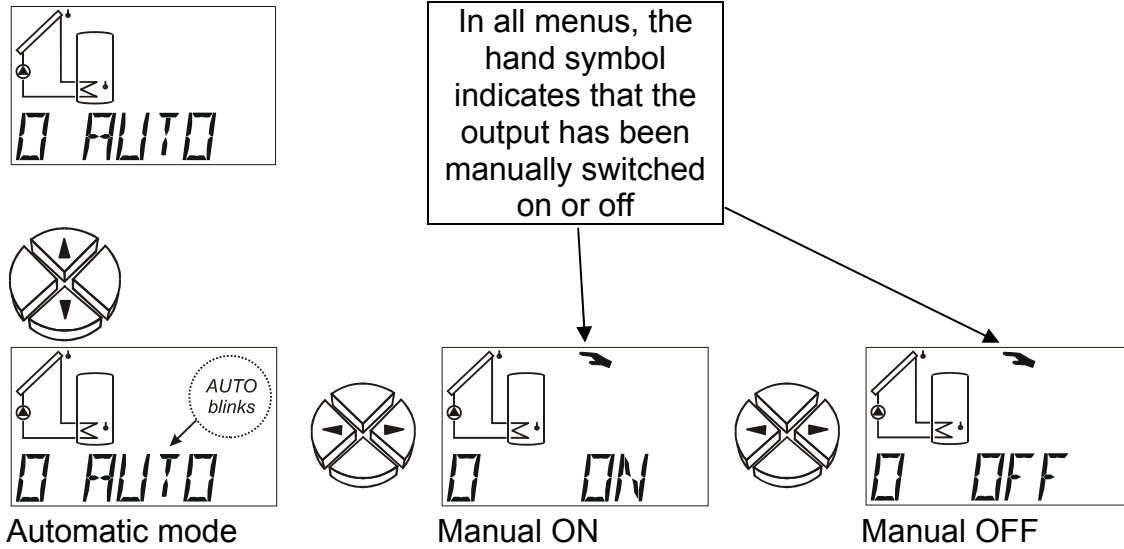

C AUTO The control output is set to automatic mode and can be switched for test purposes to manual mode (**C ON**, **C OFF**). When the manual mode has been selected, an icon appears at the top. **If the hand symbol is displayed, the control function is deactivated.** (ex works = AUTO)

Settings: **AUTO** the control output delivers a control voltage between 0 and 10 volts dependent on the settings in the **COP** menu.
ON the control voltage is always 10 volts
OFF the control voltage is always 0 volts

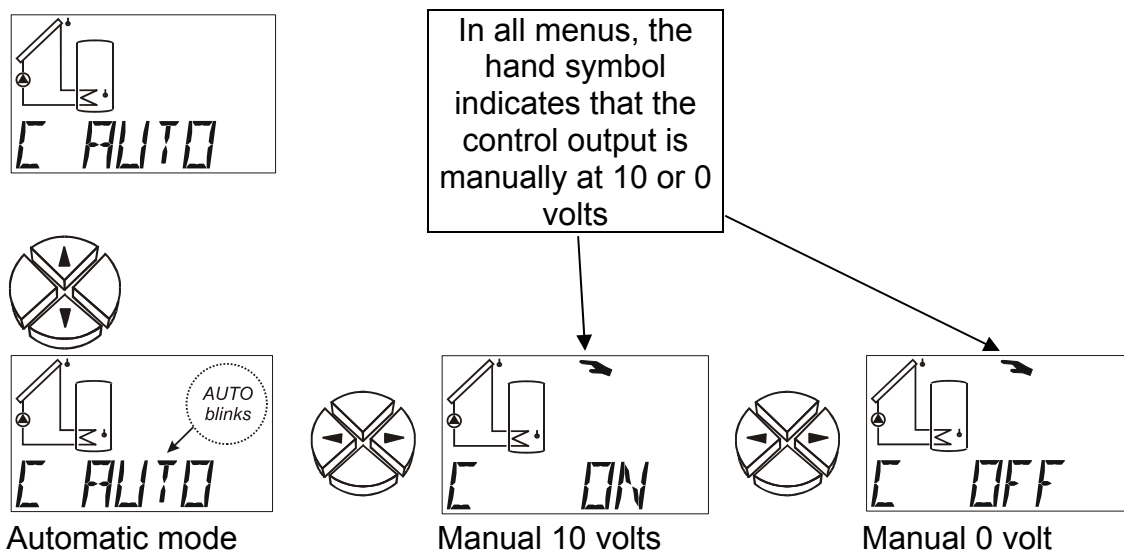

The menu MEN

The menu contains basic settings to specify additional functions such as sensor type, function check, etc. Navigation and changes are done as usual with the keys $\Rightarrow \uparrow \downarrow \Leftarrow$, while the dialogue is only set up in the text line.

As the settings in the menu can change the basic features of the control unit, only a technician who has the code can open this level.

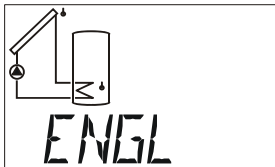
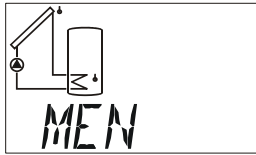

Language

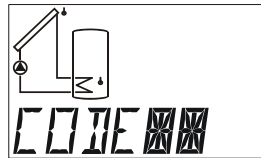

Code to enter the menu

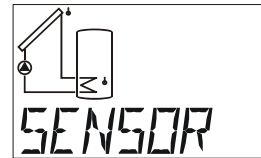

Sensor menu

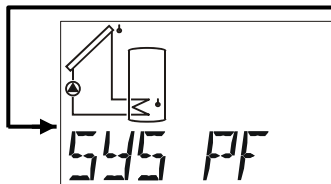

System protection function

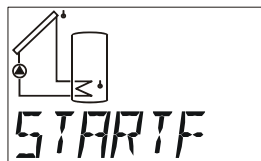

Start function

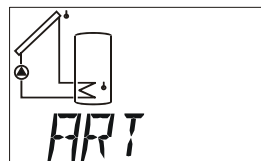

After-running time of output

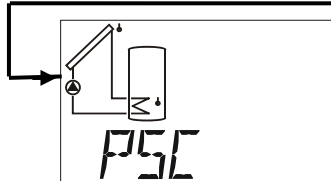

Pump speed control

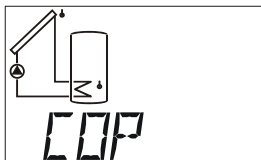

Control output

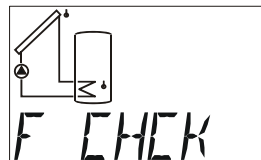

Function check

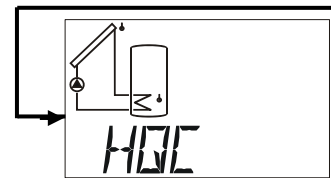

Heat quantity counter

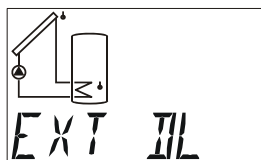

External sensors via DL bus

ENGL Language selection: The entire menu can be switched to the desired user language even before the code is provided. The following languages are available: German (**DEUT**), English (**ENGL**).

CODE Code number for entering the menu. The rest of the menu items are only displayed once the correct code number is entered.

- SENSOR** **Sensor** menu: indication of the type of sensor or a fixed temperature for an input that is not used.
- SYS PF** **System protective functions**: switch off the solar thermal system when a critical collector temperature has been reached; anti-freeze function for the collector.
- STARTF** **Start function**: start help for solar thermal systems.
- ART** **After-running time**: can be set for the output.
- PSC** **Pump speed control** (only for speed version VD)
- COP** **Control output** (0-10V / PWM)
 As analogue function (0-10 V): output of a voltage between 0 and 10 V.
 As fixed value of 5V to supply vortex sensors without data link connection.
 As PWM (pulse width modulation): output of a frequency. The duty cycle (ON / OFF) conforms to the control signal.
 Error message (switchover from 0V to 10V or inversely from 10V to 0V)
- FCHCK** **Function check**: activates a monitoring function to detect various errors and critical situations.
- HQC** **Heat quantity counter** - activate and make settings
- EXT DL** External sensor values from the DL bus.

Language DEUT, ENG:

Language selection: The entire menu can be switched to the desired user language even before the code is provided. The following languages are available: German (**DEUT**) and English (**ENGL**).

Factory settings are made in German (**DEUT**).

Code number CODE:

The other menu items of the parameter menu are displayed only after the correct code has been entered. Since the settings in the menu change the basic properties of the control module entry is restricted by code number which is only available to the technician.

Sensor menu SENSOR:

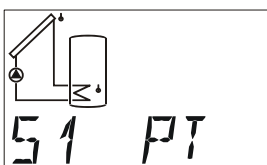
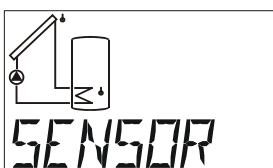

Sensor 1

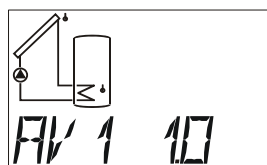

Determination of average

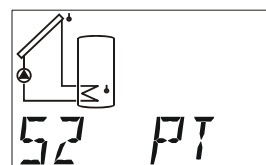

Sensor 2

...

These 2 menu items (sensor type, determination of average) are available for each sensor.

Sensor settings:

Sensor S3 has been used as example for the sensor settings, since this sensor has the most setting options.

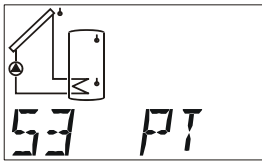

Sensor (3x)

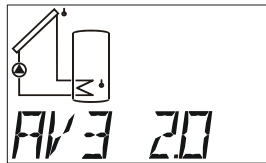

Determination of average

...

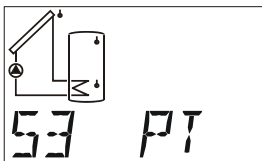

PT1000

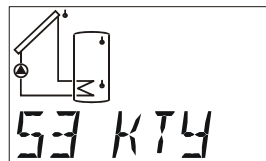

KTY

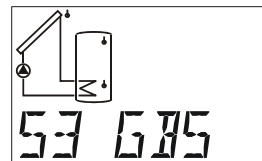

Radiation sensor

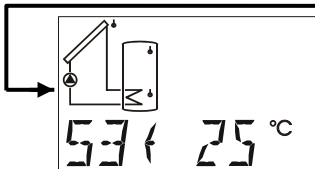

Fixed value

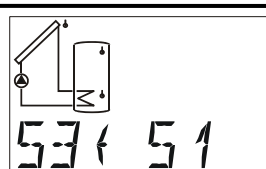

Transfer of values

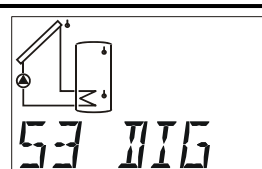

Digital input

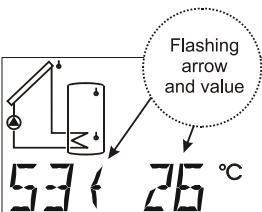

Fixed value entry setting

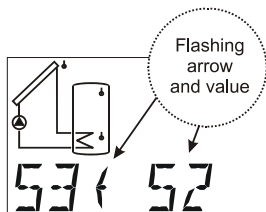

Transfer of values setting

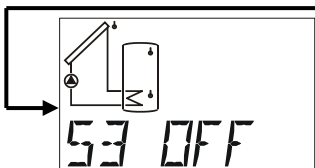

Sensor OFF

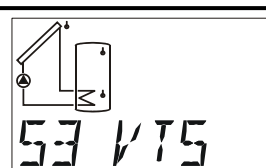

Vortex sensor temperature

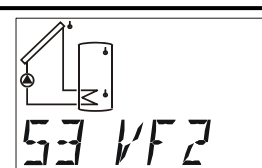

Vortex sensor Volume 2-40l/min

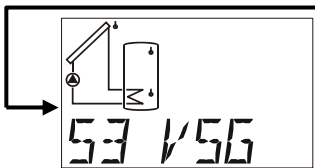

Vol. flow encoder (pulse encoder)



Connection of sensors for the flow measurement (VF2, VSG) is only possible to input 3.

Sensor type:

Solar collectors reach standstill temperatures of 200 to 300°C. No value above 200°C is expected due to the sensor installation point and physical properties (dry steam does not conduct heat well, for instance). The standard PT1000 series sensors can be permanently exposed to 250°C and briefly to 300°C. KTY10 sensors are designed for brief use at 200°C. The **SENSOR** menu enables changing over of the individual sensor inputs between PT1000 and KTY types.

As default factory setting all inputs are set to PT (1000) type.

PT, KTY	Temperature sensors
GBS	Radiant sensor GBS - non-standard accessory (can be used for the start function)
S3↔ 25	Fixed value: e.g. 25°C (using this settable value instead of measured temperature) Setting range: -20 to +149°C in increments of 1°C
S3↔ S1	Transfer of values. Instead of a measured value the input S3 receives its (temperature) information from input S1 . A mutual allocation (in this example also: S1 ↔ S3) in order to link information is not admissible. In addition it is possible to assign values from external sensors (E1 to E6).
DIG	Digital input: such as when a volume flow switch is used. Input short-circuited: Display: D1 Input interrupted: Display: D0
OFF	The sensor is not displayed on the main level
VTS	Vortex sensor (electronic volume flow encoder) temperature signal
VF2	Vortex sensor (electronic volume flow encoder; contact-free measurement of the volume flow) volume flow 2-40l/min. Only on input 3
VSG	Volume flow encoder (pulse encoder): Only on input 3 , to read-in the pulses from a volume flow encoder (determination of the flow rate for the heat quantity counter)

A 5V output (control output) is available for the power supply to the electronic volume flow encoder.

Creating a mean (average):

AV1 1.0 Create an **average** of sensor S1 for **1.0** seconds (ex works = 1.0s)
 Set the number of seconds during which an average should be calculated.
 For simple measurements, 1.0-2.0 should be selected.
 A large average slows everything down and is only recommended for the sensors for the heat counter.
 The measurement of the ultra fast sensor for the preparation of hot water also requires a fast evaluation of the signal. Hence, the determination of average of the sensor is reduced by the programs 16 and 17 to 0.4, although fluctuations will then occur in the display. No averaging is possible for the volume flow encoder, VSG.
 Setting range: 0.0 to 6.0 seconds in increments of 0.1 seconds
 0.0 = no average

System protection functions SYS PF:

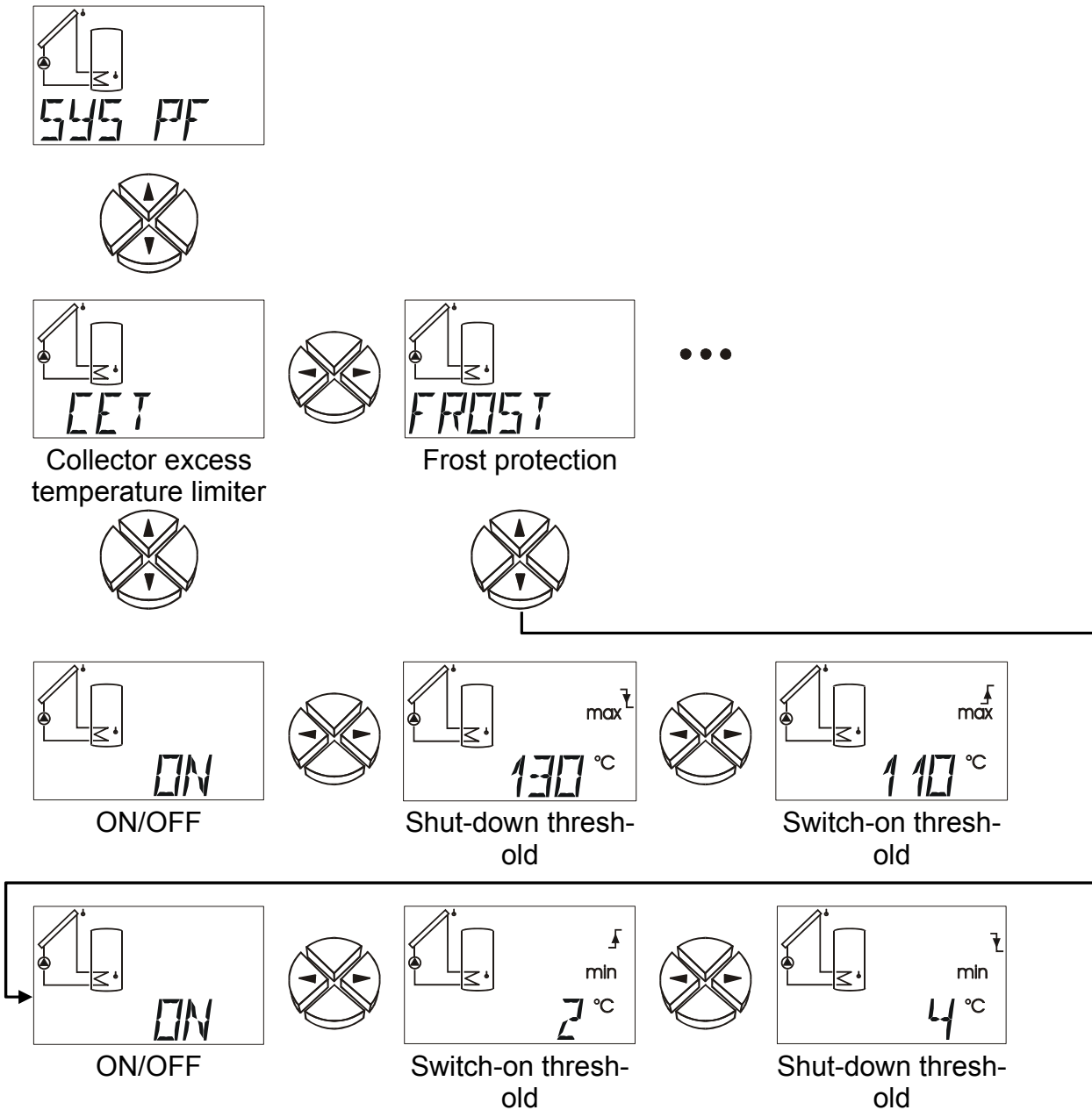

Collector excess temperature CET: Steam occurs in the system during standstill. When the system automatically switches on again, the pump does not have enough pressure to raise the fluid level above the highest point in the system (collector supply line). This represents a considerable load on the pump when there is no circulation. This function allows the pump to be blocked whenever the collector reaches a certain temperature (**max ↓**) until a second settable threshold (**max ↑**) has been crossed.

ON / OFF Collector excess temperature limit ON/OFF (ex works = ON)

max ↓ Temperature above which the outputs set are to be blocked
(ex works = 130°C)

Setting range: +1°C to +200°C in increments of 1°C

max ↑ Temperature above which the outputs set are to be released.
(ex works = 110°C)

Setting range: 0°C to +199°C in increments of 1°C

Collector anti-freeze FROST: in the south, a minimum temperature in the collector can bridge the few hours near freezing using energy from the tank. The settings in the chart cause the solar pump to be released when the threshold **min ↑** of 2°C is exceeded at the collector sensor and blocked again when the threshold **min ↓** of 4°C is surpassed. If the control output is allocated to the output, then analog step 100 is additionally output at this control output.

ON / OFF Frost-protection function ON/OFF (ex works = OFF)

min ↑ Temperature above which the outputs set are to be switched on (ex works = 2°C)
Setting range: -30°C to +149°C in increments of 1°C

min ↓ Temperature above which the outputs set are to be switched off (ex works = 4°C)
Setting range: -29°C to +150°C in increments of 1°C

NOTICE: If the frost protection function is activated and an error occurs at the set collector sensor (short circuit, interruption), the set output is switched on at the top of every hour for 2 minutes.

Start function *STARTF* (ideal for tube collectors)

Solar thermal systems sometimes start too late in the morning when the collector sensor does not come into contact with the warm heat transfer medium in time. Flat collector fields or **vacuum tubes** with forced circulation often lack sufficient gravity pull.

The start function tries to release a rinsing interval while constantly monitoring the collector temperature. If the control output is allocated to the output, then analog step 100 is additionally output at this control output. The computer first determines the current weather based on constant measurements of the collector temperature. It then calculates the best time for a brief rinsing interval to maintain the temperature for normal operation.

The start function is disabled ex works and only useful with solar thermal systems. When activated, the following flow diagram applies:

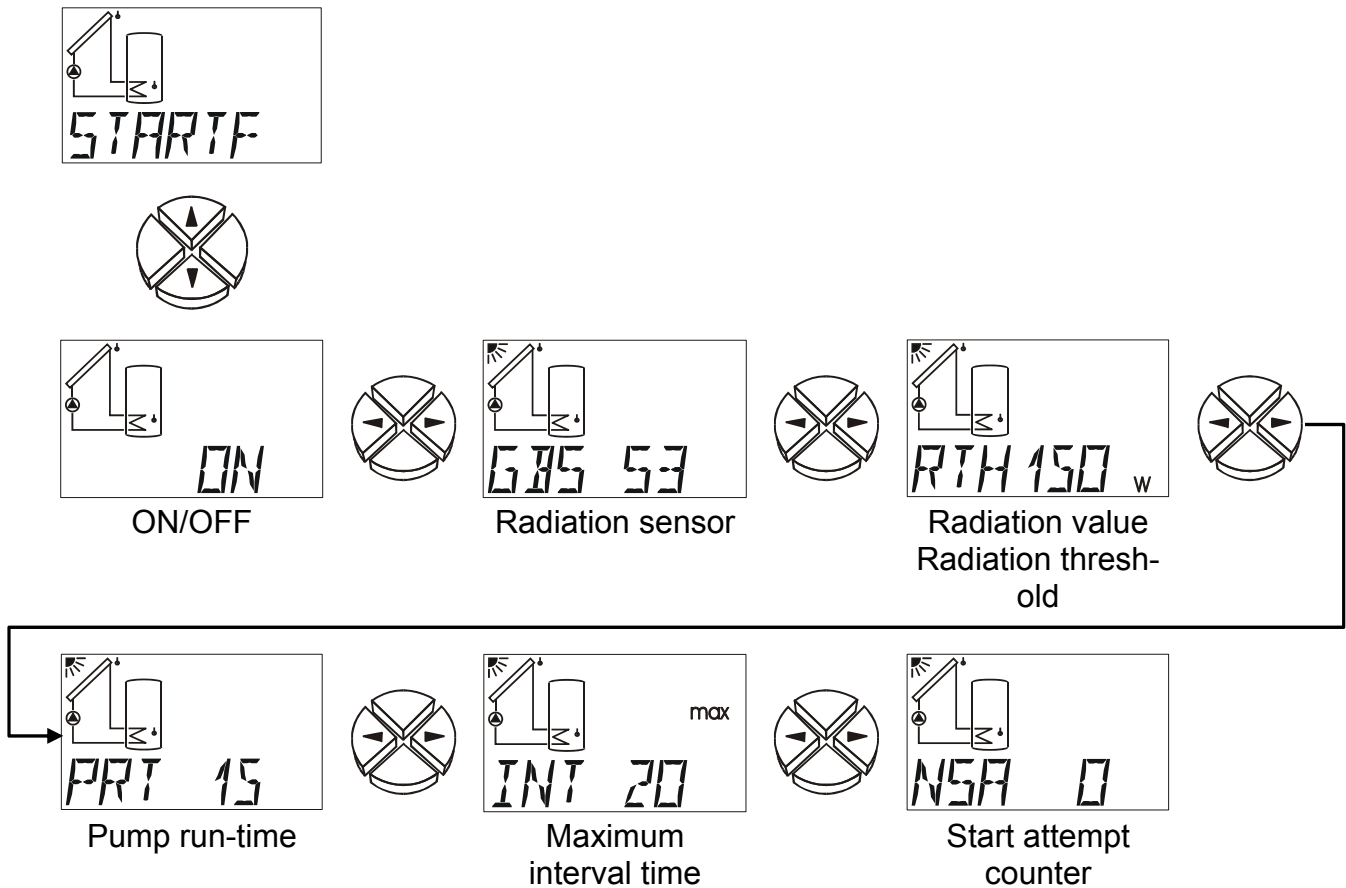

ON / OFF Start function ON/OFF (ex works = OFF)

GBS Indicates a sensor input if a radiation sensor is used. If no radiation sensor is used, the average temperature (long-term mean regardless of the weather) is calculated. (ex works = --)

Setting range:	S1 to S3	Input of radiation sensor
	E1 to E6	value of the external sensor
	GBS --	= no radiation sensor

- RTH** Radiation value (radiation **threshold**) in W/m^2 above which rinsing is allowed. Without a radiation sensor, the computer calculates the necessary temperature increase for the long-term mean that launches rinsing from this value. (ex works = $150W/m^2$)
Adjustment range 0 to 990 W/m^2 in 10 W/m^2 steps
- PRT** Pump run-time (rinsing time) in seconds. During this time, the pump should have pumped roughly half of the content of the collector's heat transfer medium past the collector sensor. (ex works = 15s)
Adjustment range 0 to 99 seconds
- INT(max)** Maximum allowable **interval** between two rinses. This time is automatically reduced according to the temperature increase after rinsing. (ex works = 20min)
Adjustment range 0 to 99 minutes
- NSA** Number of **start attempts** (= counter). The system is automatically reset for a start attempt if the last start attempt was more than four hours ago.

After-running time **ART**:

During the start phase, the pumps may repeatedly switch on and off for a long time, especially with solar and heating systems with long hydraulic system lines. This response can be reduced by using a speed control or increasing the pump after-run time.

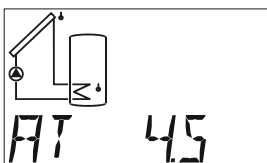
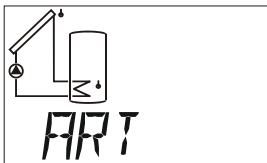

After-running time
output

- AT** After-running time output (ex works = 0)
Setting range: 0 (no after-running time) to 9 minutes in increments of 10 seconds

Pump speed control PSC: (only ESR31-D)

Warning! The values in the following description are by way of example only; they must, in all cases, be matched to the system!

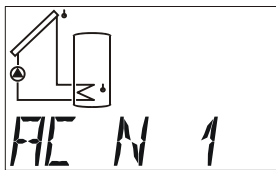
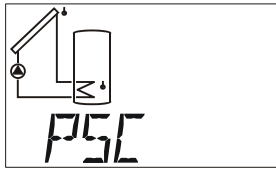

Absolute value control system

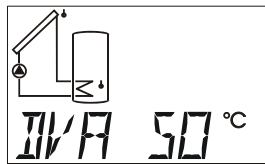

Desired value for absolute value control

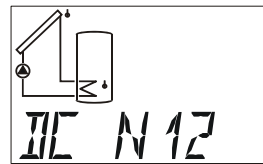

Differential control system

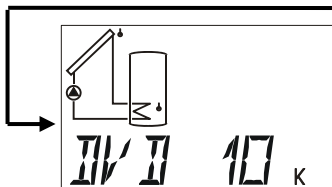

Desired value for differential control

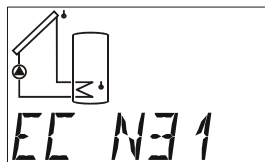

Event control system



Desired value of the event

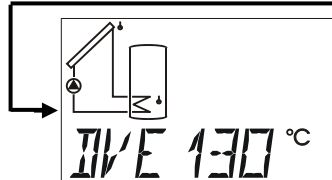

Desired value of the control system

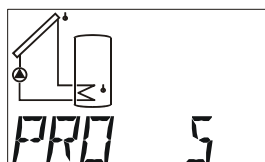

Proportional part

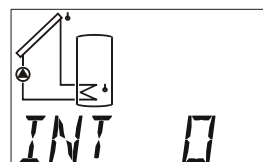

Integral part

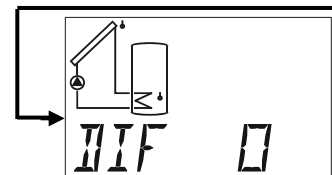

Differential part

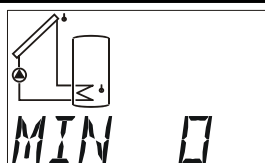

Minimum Speed stage

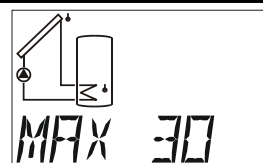

Maximum Speed stage

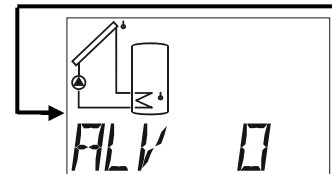

Delay time

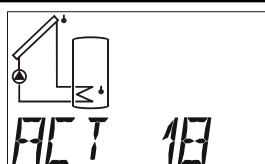

Current speed

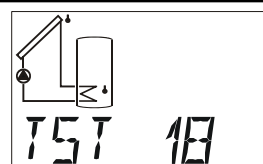

Setting of test speed

The pump speed control can be used to change the delivered quantity - i.e. the volume flow - of usual commercial circulating pumps in 30 steps. This provides constant levels of (differential) temperatures in the system.

The speed control is disabled ex works. When active, it receives the signal to control from the overriding differential switch, i.e. the basic function determined by the diagram and program number.

Simple solar controller

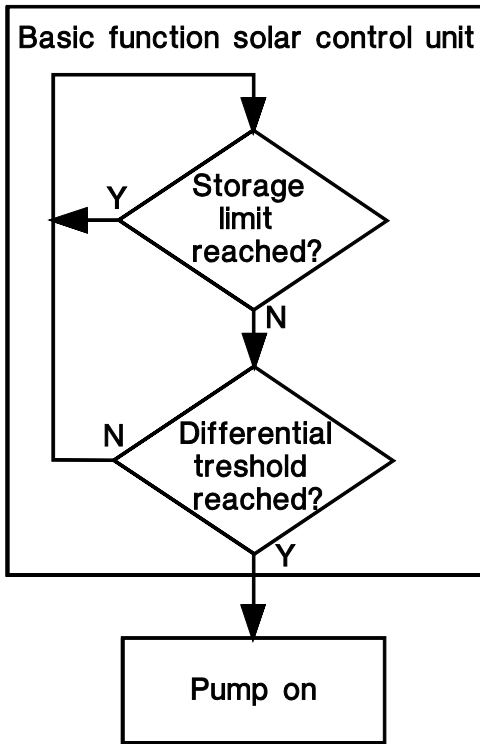

Solar controller with activated speed control

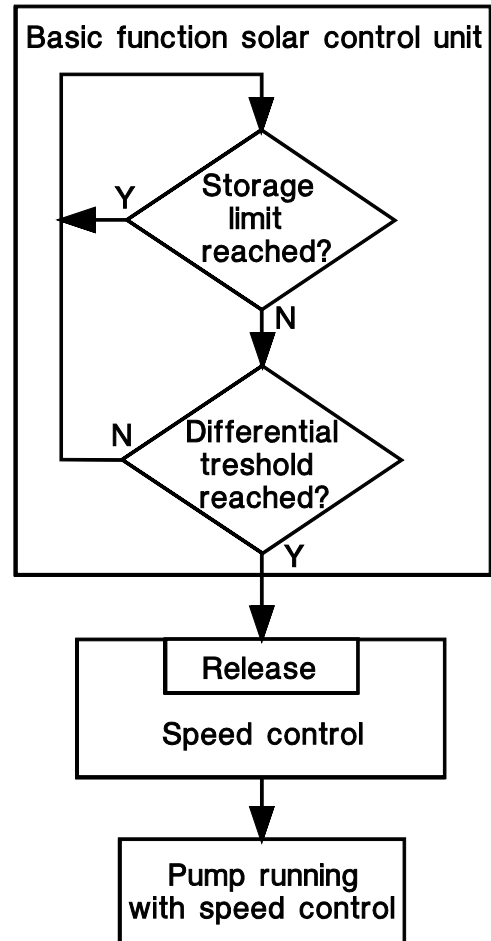

This simple solar diagram will now be used to show the possibilities of this process:

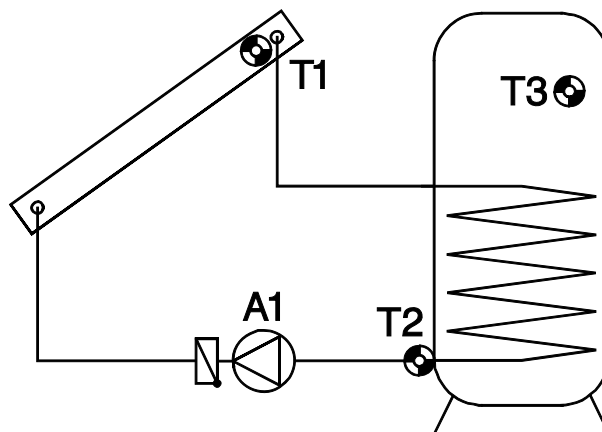

Absolute value control = maintaining a sensor

S1 can be kept at one temperature (such as 60°C) very well by using the speed control. If the solar radiation is reduced, S1 becomes colder. The control unit then lowers the speed and hence the flow rate. However, that causes the warm-up time of the heat transfer medium in the collector to increase, thus increasing S1 again.

A constant return (S2) may make sense as an alternative in various systems (such as boiler feeds). Inverse control characteristics are necessary for this. If S2 increases, the heat exchanger does not provide enough energy to the tank. The flow rate will then be reduced. The longer dwell time in the exchanger cools the heat transfer medium more, thus reducing S2. It does not make sense to keep S3 constant as the variation in the flow rate does not directly affect S3; hence, no regulator circuit will result.

The absolute control is set via two parameter windows. The example has typical settings for the hydraulics:

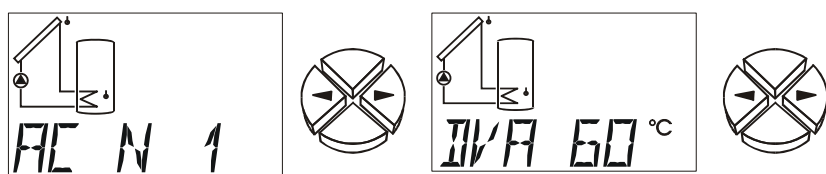

AC N 1 Absolute value control in normal operation, with sensor S1 being kept constant.

Normal operation **N** means that the speed increases as temperatures do and is valid for all applications to keep a “feed sensor” constant (collector, boiler, etc.)

Inverse operation **I** means that the speed decreases as temperatures drop and is necessary to maintain a return or control the temperature of a heat exchange outlet via a primary circulating pump (such as hygienic hot water). If the temperature at the heat exchanger’s outlet is too high, too much energy yield enters the heat exchanger, thus reducing the speed and hence the input. (ex works = --)

Setting range: AC N 1 to AC N 3, AC I 1 to AC I 3
 AC -- = absolute value control is disabled (ex works = --).

DVA 60 The desired value for absolute value control is 60°C. In the example, S1 is thus kept at 60°C. (ex works = 50°C)

Setting range: 0 to 99°C in increments of 1°C

Differential control = keeps the temperature constant between two sensors.

Keeping the temperature difference constant between S1 and S2, for instance, allow for “shifting” operation of the collector. If S1 drops due to lower irradiation, the difference between S1 and S2 thus drops. The control unit then lowers the speed, which increases the dwell time of the medium in the collector and hence the difference between S1 and S2.

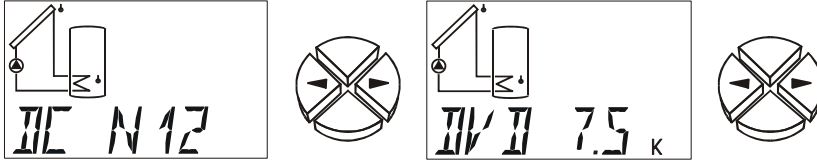

DC N12 Differential control in normal operation between sensors S1 and S2 (ex works = --).

Setting range: DC N12 to DC N32, DC I12 to DC I32)
DC -- = differential control is disabled.

DVD 7.5 The desired value for differential control is **7.5K**. In the example, the temperature difference between S1 and S2 is maintained at 7.5K.

Warning: DVD always has to be greater than the switch-off difference of the basic function. If the DVD is lower, the basic function of pump release blocks before the speed control has reached the desired value. (ex works = 10K)

Setting range: 0.0 to 9.9K in increments of 0.1K
10 to 99K in increments of 1K

If the absolute value control (maintaining a sensor) and the differential control (maintaining the difference between two sensors) are both active, the slower of the two speeds “wins out”.

Event control = If a set temperature event occurs, the speed control starts, thus keeping a sensor constant.

If, for instance, S3 reaches 55°C (activation threshold), the collector should be kept at a certain temperature. Maintaining a sensor then works as with absolute value control.

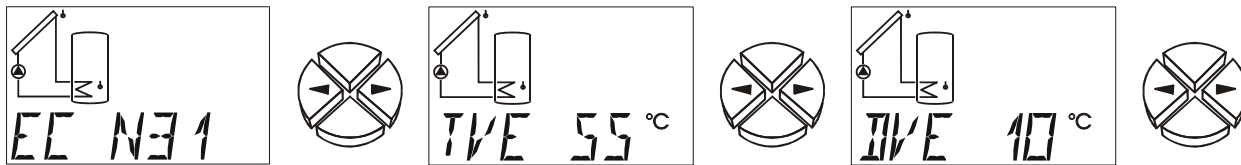

EC N31 Event control in normal operation, an event at sensor S3 leads to a constant level at sensor S1. (ex works = --)

Setting range: EC N12 to EC N32, EC I12 to EC I32)

EC -- = event control is disabled.

TVE 55 The threshold value for event control is 55°C. At a temperature of 55°C at S3, the speed control is activated. (ex works = 60°C)

Setting range: 0 to 99°C in increments of 1°C

DVE 10 The desired value for event control is 10°C. As soon as the event has occurred, S1 is kept at 10°C. (ex works = 130°C)

Setting range: 0 to 199°C in increments of 1°C

The event control “overwrites” the speed results from other control methods. A set event can thus block the control of absolute values or differences.

In the example, keeping the collector temperature at 60°C with the absolute value control is blocked when the tank has already reached 55°C at the top = the fast provision of hot water is complete and is now to be continued with full volume flow (and hence a lower temperature but slightly better efficiency). To do so, a value that value automatically requires full speed (such as S1 = 10°C) has to be entered as the new desired temperature in the event control.

Waveform

Wave packets - only for circulating pumps with standard motor dimensions. Here, individual half cycles are bled in to the pump motor. The pump runs on pulses and only produces a smooth flow of the heat transfer medium when the rotor’s moment of inertia has been overcome.

Benefit: Great dynamics of 1:10, well suited for usual commercial pumps without internal electronics and a motor length of around 8 cm.

NB: Linearity depends on the pressure loss; there is some noise, not suitable for pumps with evidently deviating motor diameters and / or length from 8 cm.

Stability problems

The speed control has a “PID controller”. It ensures an exact and fast adjustment of the actual value to the set point. **In applications such as solar power systems or feed pumps, the following parameters should be left in factory settings.** With a few exceptions, the system will run stably. These two values have to be balanced, however, especially for hygienic hot water from the external heat exchanger. In addition, in this case the use of an ultrafast sensor (non-standard accessory) is recommended at the hot water outlet.

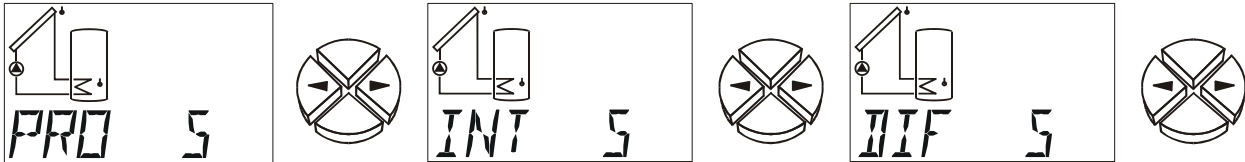

Set value = desired value

Actual value = temperature measured

- PRO 5** **Proportional part of the PID controller 5.** It represents the reinforcement of the deviation between the desired and the actual value. The speed is changed by one increment for each 0.5K of deviation from the desired value. A large number leads to a more stable system but also to more deviation from the predefined temperature. (ex works = 5) Setting range: 0 to 9
- INT 5** **Integral part of the PID controller 5.** It periodically adjusts the speed relative to the deviation remaining from the proportional part. For each 1K of deviation from the desired value, the speed changes one increment every 5 seconds. A large number provides a more stable system, but it then takes longer to reach the desired value. (ex works = 0) Setting range: 0 to 9
- DIF 5** **Differential part of the PID controller 5.** The faster a deviation occurs between the desired and the current value, the greater the short-term overreaction will be to provide the fastest compensation possible. If the desired value deviates at a rate of 0.5K per second, the speed is changed by one increment. Large numbers provide a more stable system, but it then takes longer to reach the desired value. (ex works = 0) Setting range: 0 to 9

The parameters PRO, INT, and DIF can also be determined in a test: Assume that the pump is running in automatic mode in a unit that is ready for operation with appropriate temperatures. With INT and DIF set to zero (= switched off), PRO is reduced every 30 seconds starting at 10 until the system is instable. In other words, the pump speed changes rhythmically and can be read in the menu with the command ACT. Every proportional part that becomes instable is noted as P_{krit} just as the duration of the oscillation (= time between the two highest speeds) is noted as t_{krit} . The following formulas can be used to determine the correct parameters.

$$PRO = 1,6 \times P_{krit}$$

$$INT = \frac{PRO \times t_{krit}}{20}$$

$$DIF = \frac{PRO \times 8}{t_{krit}}$$

A typical result of hygienic service water with the ultrafast sensor is PRO = 8, INT = 9, DIF = 3. For reasons not entirely understood, the setting PRO = 3, INT = 1, DIF = 4 has proven practical. Probably, the control unit is so unstable that it oscillates very quickly and appears to be balanced due to the system's and the fluid's inertia.

Pump standstill

The wave packet method allows for variations in the volume flow by a factor of 10 in 30 increments. If the flow rate is too low, flap valves may cause a system standstill. In addition, low power stages at low speeds may cause the rotors to stop. Such a standstill may sometimes be desired, which is why stage 0 is allowed as the lowest stage. The following parameters determine the lower and upper limit for speeds:

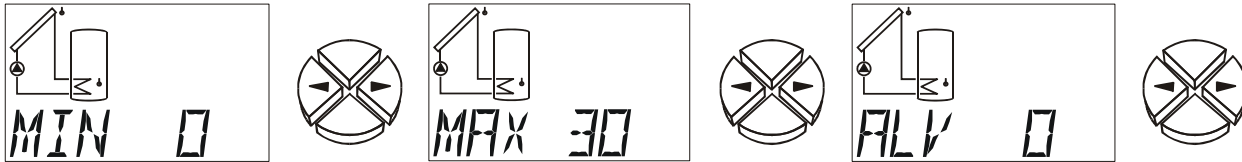

- MIN** Lower speed limit (ex works = 0)
- MAX** Upper speed limit (ex works = 30)

The best speed limit is found in a simple test. Use the command TST to set a speed for testing. Remove the rotor lid to see the rotor. Then lower the speed until the rotor stops. Set the limit three increments above this point to ensure safe pumping.

- ALV** Delay time - After switching the output on via the differential function the circulating pump runs for the period entered with no speed control and at full speed. Only after expiry of the period is control of the speed allowed and the output controlled.
This function is envisaged for drain-back systems which, after switching on the solar pump have to be filled at top speed (= maximum pressure).
Adjustment range: 0 to 9 minutes in 10-second increments (ex = 0)

Control commands

The following commands provide a test of the system (see pump standstill) and allow you to monitor the current speed (see stability problems):

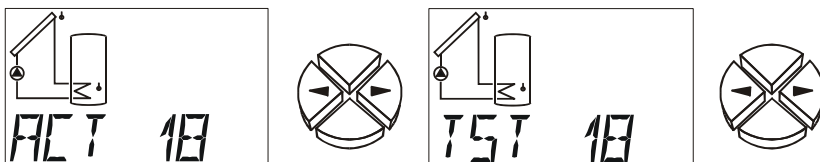

- ACT 18** The pump is currently running at stage **18** (actual value).
- TST 18** The speed stage **18** is currently being tested. Calling TST automatically switches to manual mode. As soon as the value blinks via the key ↓ (= entry), the pump runs at the speed displayed. Pressing key ↑ ends test mode again (display 0, not flashing)
Setting range: 0 to 30

Control output COP 0-10 V / PWM:

Different functions of the control output

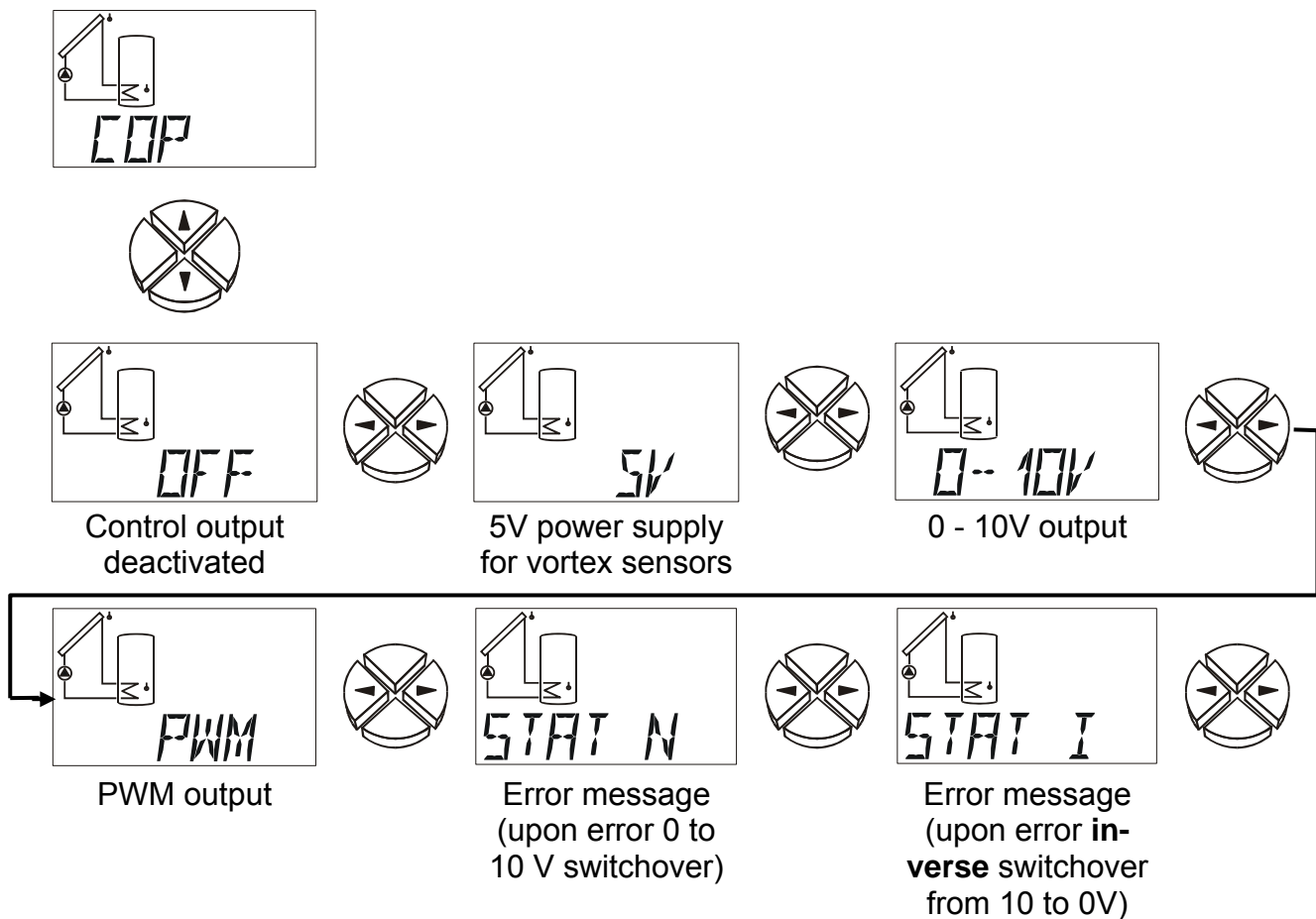

OFF Control output deactivated; output = 0V

5V Power supply for vortex sensors without DL connection (VF2, VTS) output = 5V

0-10V PID – controller; output= 0-10V in 0.1V increments

PWM PID – controller; output = duty cycle 0-100% in 1% increments

STAT N / STAT I If function **Stat** control is activated and an error message is displayed in the status display **Stat** (sensor open circuit **IR**, -short circuit **SC** or circulation error **CIRC.ER**) the output with the setting **STAT N** is switched over from 0 to 10 V (for **STAT I**: inversely from 10V to 0V). Upon collector excess temperature switch-off **CETOFF**, the control output does not switchover. Subsequently, the auxiliary relay HIREL31-STAG can be connected to the control output, which forwards the error message to a signalling device (e.g. warning lamp or audible alarm).

The following settings are only possible in **0-10V** and **PWM** modes.

Warning! The values in the following description are by way of example only; they must, in all cases, be matched to the system!

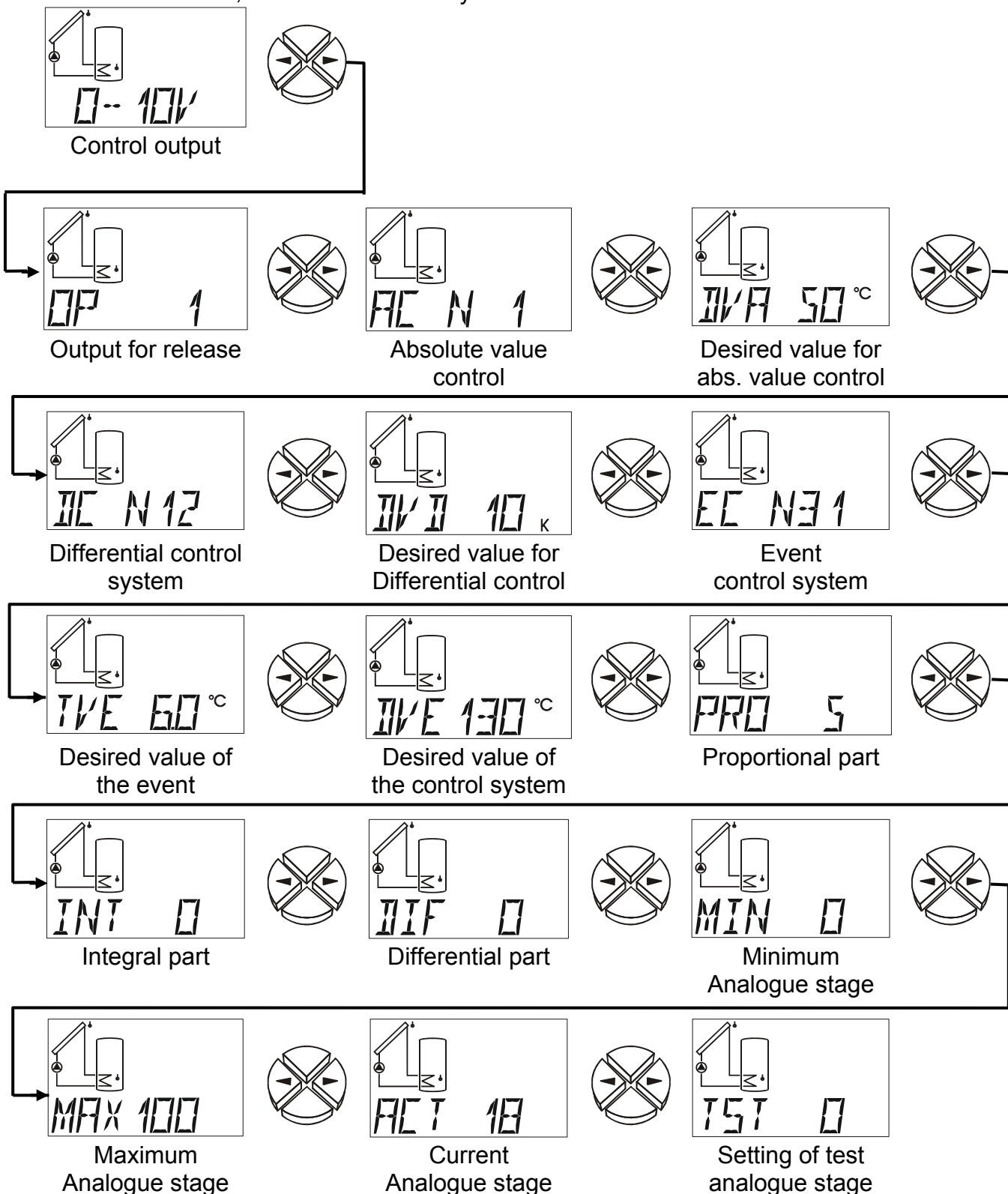

In this menu the parameters for the control output are specified. As analogue output it can put out a voltage of 0 to 10V in 0.1V increments. As PWM a digital signal with a frequency of 500 Hz (level approx. 10 V) and a variable duty cycle from 0 to 100% is created.

The behaviour of the control circuit is equal to that of the pump speed control (PSC) however instead of 30 (PSC) a maximum of 100 increments is available.

The description of the parameter values follows therefore in the menu "PSC".

- OP** Setting of the **output** to release the analogue output.
 Setting range: OP 1 = The analogue output is only released if the output is also switched on. (ex works = --)
 OP -- = The analogue output is not assigned to the output.

Function check F CHCK:

Some countries only offer subsidies for the installation of solar thermal systems if the control units have a function check to detect a sensor defect and a lack of circulation. In the menu command **F CHCK**, the mechanic can activate this function check for the ESR31. This function check is disabled ex works.

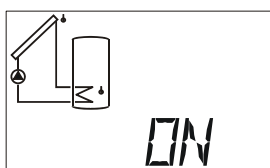
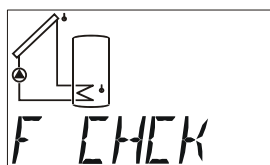

ON/OFF

OFF: The function check is not active.

ON: The function check is active. Monitoring makes most sense in solar thermal systems. The following system statuses and sensors are monitored:

- ◆ An interruption or short circuit of one or more sensors.
- ◆ Circulation problems - an error message is issued if the output is active and the differential temperature between collector S1 and tank S2 is greater than 60K for more than 30 minutes.

The error messages are entered in the menu **△Status**.

If **△Status** is blinking, a malfunction has been detected (see "The status display **△Status**").

If the control output is set to "STAT N" or "STAT I" and the function control is activated, then if an error occurs, the control output is switched over. Subsequently the auxiliary relay HIREL31-STAG can be used to forward this error message to a signalling device.

Heat quantity counter HQC:

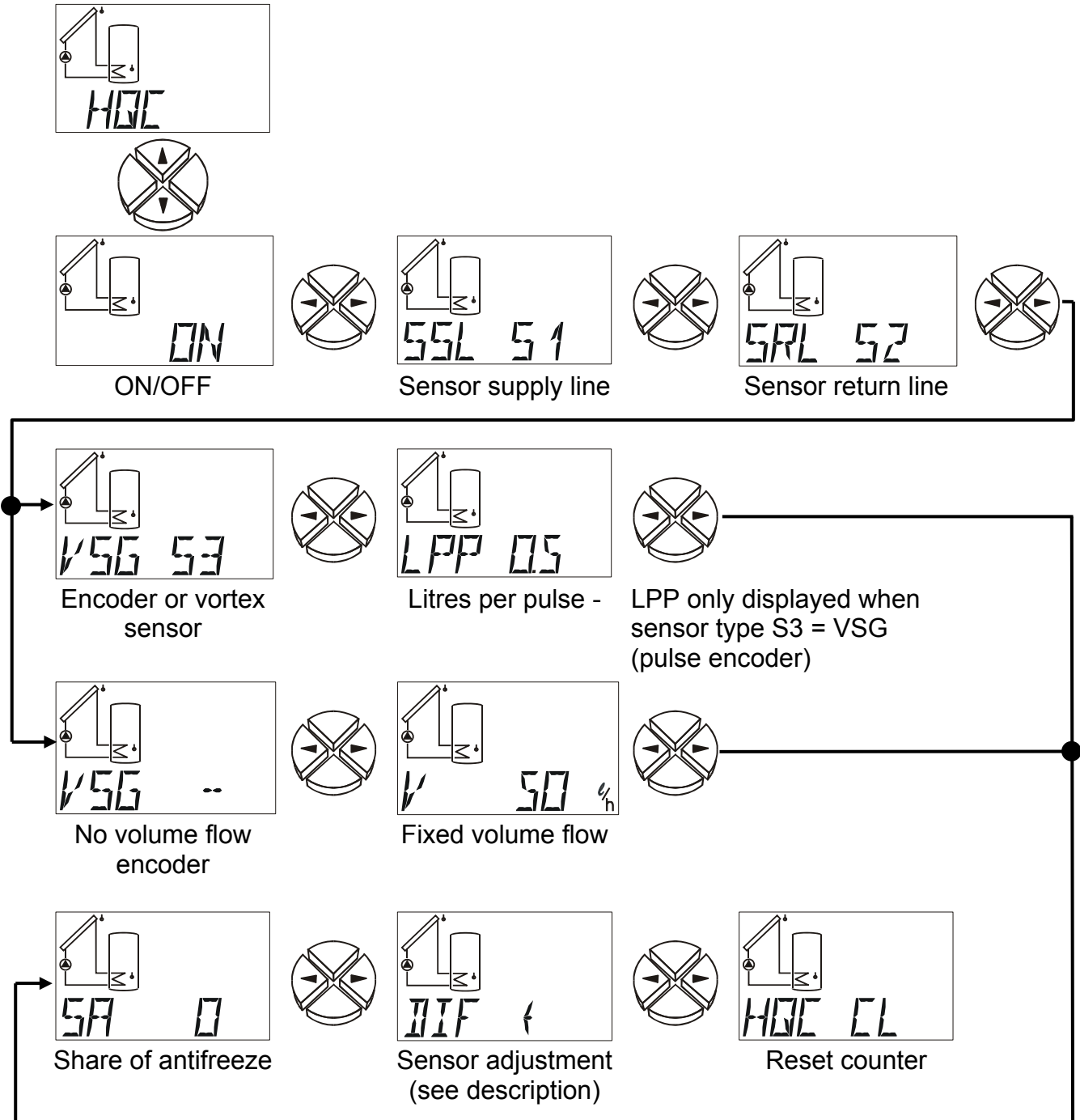

The device also has a function to count the heat quantity. It is disabled ex works. A heat quantity counter basically requires three types of information:

- ◆ **supply line temperature**
- ◆ **return line temperature**
- ◆ **flow rate (volume flow)**

In solar thermal systems, the correct installation of sensors (see sensor installation - collector sensor on the supply line's collecting tube, tank sensor on the outlet of the return line) automatically leads to correct measurements of the required temperatures, though the losses in the supply line will be included in the heat quantity. To increase accuracy, in indication of the share of antifreeze in the heat transfer medium is necessary as the antifreeze lowers heat conduction.

The setting of the type of volume flow encoder used is made in menu "SENSOR".
A volume flow encoder can only be connected to **input S3**.

S3 = KTY, PT, GBS, fixed value, accept value, digital, OFF or VTS (Vortex temperature)
= **No volume flow encoder**

S3 = VF2 (vortex sensor 2-40l/min)

A vortex volume flow encoder (**electronic** volume flow encoder VFS 2-40) is connected to input S3.

S3 = VSG

The volume flow encoder on input 3 is a type **with pulse encoder**.

ON/OFF select / disable heat counter (ex works = OFF)

SSL Sensor input for **supply** line temperature (ex works = S1)

Setting range: S1 to S3 Input of the pre-run sensor
 E1 to E6 Value from external sensor

SRL Sensor input for **return** line temperature (ex works = S2)

Setting range: S1 to S3 Input of the return sensor
 E1 to E6 Value from external sensor

VSG Sensor input for volume flow encoder. (ex works = --)

Settings: VSG S3 = Volume flow encoder on input 3

 VSG E1 to E6 = Value from external sensor

 VSG -- = no volume flow encoder → fixed volume flow. For the heat quantity calculation the fixed setting of the volume flow is taken, however only if the set output is activated. (pump runs)

LPP **Litres per pulse** = the volume flow encoder's pulse rate (only when a pulse encoder is used) It depends on the system. The sensor supplied by the manufacturer of the control unit has a pulse rate of 0.5 litres per pulse. (ex works = 0.5)

Setting range: 0.0 to 10.0 litres/pulse in increments of 0.1 litre/pulse

V **Volume flow in litres per hour**. If no volume flow encoder has been set, a fixed volume flow can be preset in this menu. If a set output is not active, the volume flow is assumed to be 0 litres/hour.

As activated speed control can produce constant changes in volume flow, this method is not suited to use with speed control. (ex works = 50 l/h)

Setting range: 0 to 20000 litres/hour in increments of 10 litre/hour

SA **Share of antifreeze** in the heat transfer medium. An average has been calculated from the product specifications of all of the major manufacturers; this average is used in the table of mixing ratios. This method generally produces an additional maximum error of one percent. (ex works = 0%)

Setting range: 0 to 100% in increments of 1%

DIF Temporary temperature **difference** between the supply and return line sensor (Maximum display ± 8.5 K, additionally an arrow is displayed). If both sensors are immersed in one bath for test reasons (with both thus measuring the same temperatures), the device should display “**DIF 0.0**”. Sensor and measurement equipment tolerance may, however, lead to a displayed difference under **DIF**. If this display is set to zero, the computer saves the difference as a correction factor and then calculates the heat amount adjusted by this natural measurement error. **This menu item thus provides a way to calibrate to system. The display may only be set to zero (i.e. changed) if both sensors have the same measurement conditions (same bath).** In addition, the temperature of the test medium should be around 40-60°C.

HQC CL Clear heat quantity counter. The cumulative amount of heat can be reset with the ↵ key (=enter).

If the amount of heat is zero, **CLEAR** is displayed in this menu item.

If the heat counter has been activated, the following are displayed in the basic menu:

the current output in kW

the amount of heat in MWh and kWh

of the volume flow in litres/hour

NOTICE: If an error (short circuit, interruption) occurs at one of the two set sensors (supply sensor, return sensor) for the heat counter, the current output is set at 0, i.e. no heat is counted.

NOTICE: As the internal storage (EEPROM) has only a limited number of write cycles, the totalled heat quantity is saved only once per hour. Consequently, if there is a power failure, the heat quantity for up to an hour can be lost.

Tips on accuracy:

A heat counter can only be as exact as its sensors and equipment. In the range from 10°C to 90°C the standard solar control sensors (PT1000) have an accuracy of approximately ± 0.5 K. For KTY sensors the equivalent figure is ± 1 K. The unit's measurement equipment is accurate down to ± 0.5 K according to laboratory measurements. PT1000 sensors may be more accurate, but they have a weaker signal that increases the error. In addition, the proper installation of the sensors is crucial and can increase error considerably if installed improperly.

If all of the tolerances cumulate in a worst-case scenario, the error would be 40% (KTY) at a typical temperature difference of 10 K! However, normally the error should be below 10% as the equipment error affects all of the input channels the same, and the sensors are from the same production batch. The tolerances thus cancel each other out somewhat. In general, the greater the differential temperature, the smaller the error. The measurement results should always be seen just as guide values in all respects. The adjustment due to measurement differences (see **DIF**) leads to a measurement error in standard applications of around 5%.

"Step by step" setting of the heat quantity counter



You have the option of using 3 different volume flow encoders:

- ◆ the pulse encoder VSG,
- ◆ the electronic volume flow encoder VFS2-40 and
- ◆ the FTS....DL, which is connected to the data link.

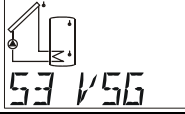

If you do not use a volume flow encoder, then you can only set a fixed volume flow.

In the following, the necessary settings are displayed "step by step".

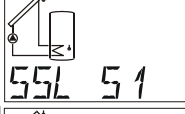
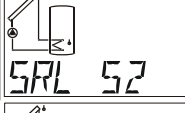
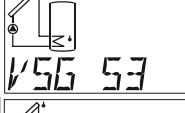
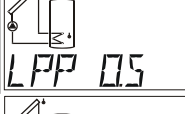
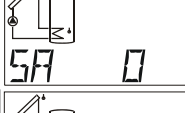
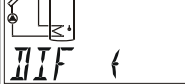

VSG (pulse encoder)

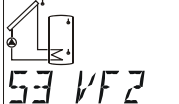
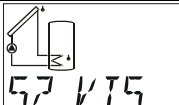
1		The VSG (pulse encoder) must only be connected to input 3, hence: menu "SENSOR", sensor setting S3 to "S3 VSG"
2		Access to menu "HQC", setting to "ON"
3		Setting of the pre-run sensor in the SSL display, in the example shown, sensor S1
4		Setting of the return sensor in the SRL display, in the example shown, sensor S2
5		Entry of "S3" in the VSG display as the VSG is the sensor S3
6		Checking and possible alteration of the LPP value (litre per impulse)
7		Indication of the antifreeze fraction SA in %
8		Possible sensor compensation as per the operating manual

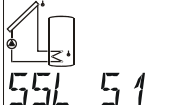
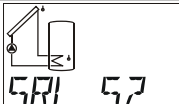
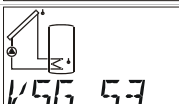
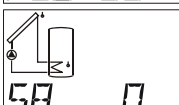
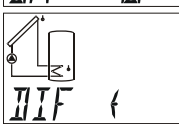
VFS2-40 (Example: fitting of the VFS2-40 in the return)

1		The VFS2-40 (electronic) must be connected to the S3 sensor input, hence: menu "SENSOR", sensor setting to "VF2" (volume flow encoder)
2		Setting of the return sensor in the SENSOR menu, when using the temperature sensor on the VFS2-40: VTS setting, in the example shown, sensor S2, when using a "normal" sensor, the setting "KTY" or "PT" remains, dependent on sensor type
3		Access to menu "HQC", setting to "ON"
4		Setting of the pre-run sensor in the SSL display, in the example shown, sensor S1
5		Setting of the return sensor in the SRL display, in the example shown, sensor S2 (see point 2)
6		Entry of the sensor number for the VFS2-40 volume flow encoder in the "VSG" display, (see point 1)
7		Indication of the antifreeze fraction SA in %
8		Sensor compensation is only possible with difficulty

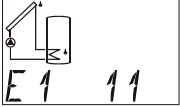
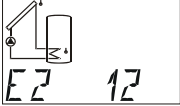
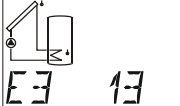
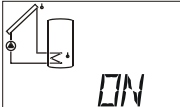
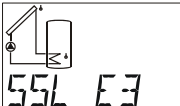
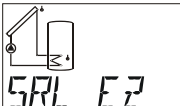
FTS....DL (Example: fitting in the return, use of an external sensor for the pre-run which is connected to the FTS4-50DL)

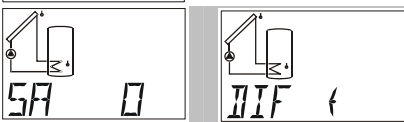
1		The FTS4-50DL is connected to the data link (external sensor), hence: menu "EXT DL", setting of the volume flow encoder in the display of the external sensor "E1": 11 (address 1, index 1)
2		Setting the sensor temperature of the FTS4-50DL for the return: menu "EXT DL", in the display "E2": 12 (address 1, index 2)
3		If an external temperature sensor is connected for the pre-run on the FTS4-50DL: menu "EXT DL", in the display "E3": 13 or 14, dependent on whether a Pt1000 or KTY sensor (address 1, index 3 or 4) is used
4		Access to menu "HQC", setting to "ON"
5		Setting of the pre-run sensor in the "SSL" display, if, as shown in the example, external sensor: E3 (see point 3), otherwise specification of the corresponding pre-run sensor S1 - S3
6		Setting of the return sensor in the SRL display, by using the temperature sensor on the FTS4-50DL: E2 (see point 2), otherwise specification of the corresponding return sensor S1 - S3
7		Display VSG: entry VSG E1, i.e. the volume flow encoder is external sensor E1 (see point 1)
8		Specification of the antifreeze fraction and sensor compensation

No volume flow encoder:

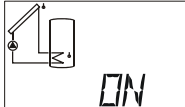
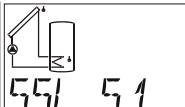
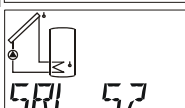
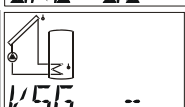
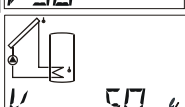
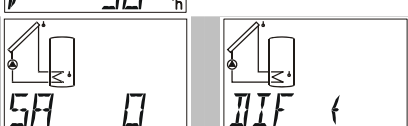
1		Access to menu "HQC", setting to "ON"
2		Setting of the pre-run sensor in the SSL display, in the example shown, sensor S1
3		Setting of the return sensor in the SRL display, in the example shown, sensor S2
4		Entry of "--" in the VSG display, as no volume flow encoder is being used
5		Entry of the fixed volume flow in litres/hour
6		Specification of the antifreeze fraction and sensor compensation

External sensors EXT DL:

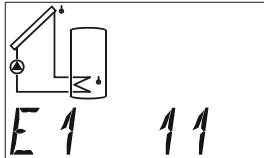
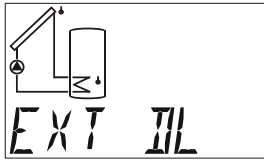

Address for external value 1

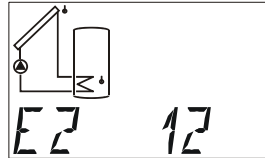

Address for external value 2

...

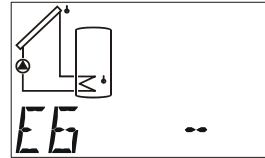

Address for external value 6

Electronic sensors for temperature, pressure, humidity, differential pressure, etc. are also available in the **DL** version. In this case, the supply and signal transmission takes place via the **DL bus**.

Up to 6 values from external sensors can be read via the DL bus.

- E1 = -- The external value 1 is deactivated and faded out in the main level.
- E1 = 11 The front number indicates the address of the external sensor. This can be set to between 1 and 8 on the sensor according to its operating instructions.
The rear number indicates the index of the sensor. Since external sensors can transmit numerous values the value required from the sensor is defined via the index.





The setting of the address and index can be taken from the respective data sheets.



Due to the relatively high power requirement, the "**bus load**" must be considered: The controller ESR31 has the maximum bus load, 100%. For example, the electronic sensor FTS4-50**DL** has a bus load of 36%, therefore up to a max. 2 FTS4-50**DL** can be connected to the DL bus. The bus loads of the electronic sensors are listed in the technical data of the respective sensors.

Simultaneous power supply to a boot loader and external sensors is not possible. In this case, the boot loader must be supplied via a power pack (CAN-NT).

Status display Status

The status display provides information in special system situations and problems. It is mostly intended for use with solar thermal systems, but can also be useful with other diagrams. The status display can then only operate if an active function check is set off via defective sensors S1 – S3. For solar applications, a distinction has to be made between three status areas:

- ◆ **Function check and collector excess temperature are not active** = no system response is analysed. Only a bar appears in the display in  **Status**.
- ◆ **Collector excess temperature is active** = the excess temperature that occurs during system standstill only leads to the display **CETOFF** (the collector's excess-temperature cut-off is active) during this time under  **Status**. The display  **Status** does not flash.
- ◆ **Function check is active** = monitoring of interruption (**IR**) and short circuit (**SC**) of the solar sensors and circulation problems. If this outlet is active and the differential temperature between collector S1 and tank S2 is greater than 60K for more than 30 minutes, the error message **CIRERR** (circulation error) is output. This status ( **Status** blinks) is maintained even after the error has been remedied and has to be cleared in the status menu using the command **CLEAR**.

In  **Status**, **OK** is displayed when the monitoring function is activated and the system's operation is correct. If there is anything unusual,  **Status** blinks regardless of the display position.

If the control output is set to "**STAT N**" or "**STAT I**" and the function control is activated, then if any of the errors "sensor open circuit, sensor short-circuit or circulation error" occur, the control output is switched over. Subsequently the auxiliary relay HIREL31-STAG can be used to forward this error message to a signalling device. Upon collector excess temperature switch-off **CETOFF**, the control output does not switchover.

Function check disabled

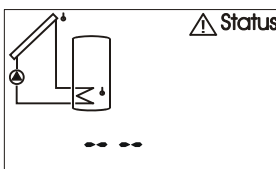

Function check disabled

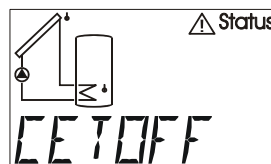

Collector - excess temperature - cut-off is active

Function check activated

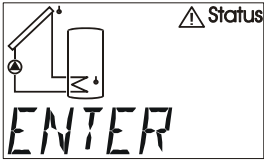

Function check activated → error occurred

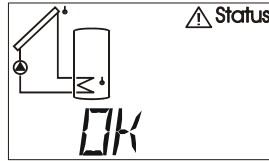

Function check → no error

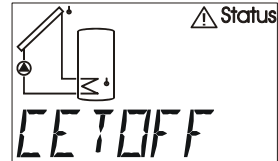

Collector - excess temperature cut-off active (no error occurred)

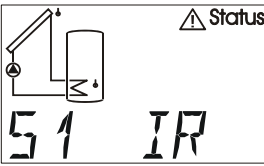

Error sensor 1 (interruption)

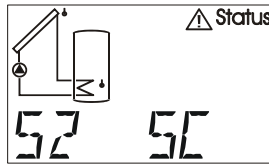

Error sensor 2 (short circuit)

...

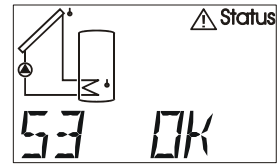

Sensor 3 no error

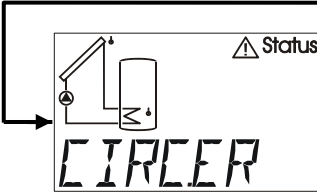
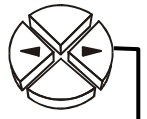

Circulation error only displayed when occurred

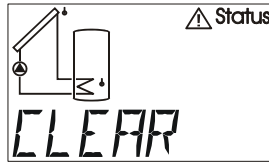

Reset error

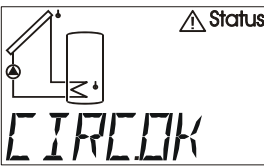

No circulation error existing

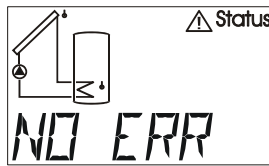

No error existing

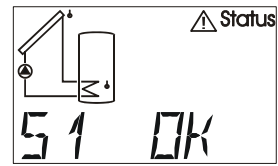

Sensor 1 OK

...

Installation instructions

Sensor installation:

The sensors must be properly arranged and installed for the system to function correctly.

- ◆ **Collector sensor (red cable):** Either insert the sensor in a pipe directly soldered or riveted to the absorber and extending out of the collector casing or screw the sensor onto a T piece on the end of the supply line's collecting tube using an immersion sleeve. No water may be allowed to enter the immersion sleeve (danger of freezing).
- ◆ **Storage sensor:** The sensor should be used with an immersion sleeve just above the outlet for the exchanger's return line if heat exchangers with ribbed tubes are used and with a T piece on the outlet of the exchanger's feed line if integrated non-ribbed tubes are used. It should not be installed below the respective register or heat exchanger in any case.
- ◆ **Boiler sensor (boiler supply line):** This sensor is either screwed into the boiler using an immersion sleeve or at a short distance from the boiler on the supply line.
- ◆ **Pool sensor (swimming pool):** Install directly at the outlet from the pool on the suction line as an attached sensor (see attached sensor). Installation using an immersion sleeve is not recommended due to the possibility of condensation within the sleeve.
- ◆ **Clip-on sensor:** Optimally secured using roll springs, pipe clamps or hose band clips to the line. Make sure the material used is proper (corrosion, temperature resistance, etc.). Then, the sensor has to be well insulated so that the pipe temperature is measured exactly and the ambient temperature does not influence the measurement.
- ◆ **Warm water sensor:** to produce warm water using an external heat exchanger a rapid reaction to changes in water quantity is absolutely critical. For this purpose the ultra-fast warm water sensor (special accessory) must be installed directly to the heat-exchanger output using T-shaped connector and installation kit.

All of the sensor cables with a cross-section of 0.75mm^2 can be extended up to 30m. Beyond 30m they can be extended by use of a suitably larger cross section. The sensor and the extension can be connected as follows: cut the heat-shrinkable sleeve provided down to 4 cm and put it over a wire; twist the naked ends of the wires, and put the heat-shrinkable sleeve over the naked end; heat it carefully (such as with a cigarette lighter) until the sleeve has wrapped itself around the connection.

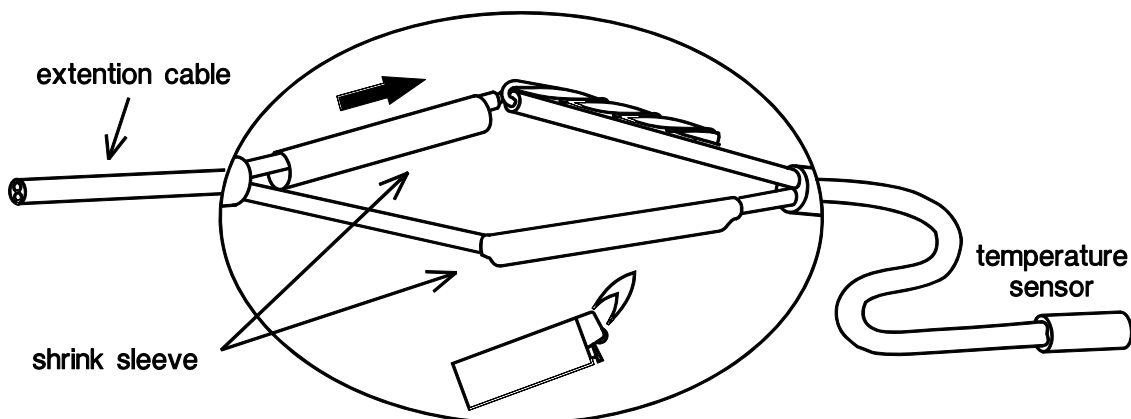

Cable laying

In order to obtain interference-free signal transmission (to avoid measurement fluctuations) the sensor lines must not be subject to interference factors. With the generally accepted use of unshielded cables sensor lines are to be laid in their own cable channel at least 20 cm away from mains cables.

Installing the device

WARNING! ALWAYS PULL THE MAINS PLUG BEFORE OPENING THE CASING!
Only work on the inside of the control system when it is dead.

Loosen the screw on the top of the casing and remove the lid. The electronics for the control unit is in the lid. Contact pins provide a connection to the clamps in the lower part of the casing when the lid is put on again. The body of the casing can be screwed to the wall (**with the cable ducts facing down**) through the two holes using the fastening materials provided.

Electrical connection

Caution: Only a trained electrician may provide the electrical connection in compliance with local guidelines. The sensor lines must not be laid in the same cable channel as the supply voltage. The maximum output load amounts to (VD) 1.5A in the speed version and (VR) 2.5A in the relay version. If filter pumps are directly connected, their rating plate must be minded. The appropriate strip terminal must be used for all protective conductors.

Note: To provide protection from lightning, the system has to be grounded in accordance with the regulations - sensor failures due to storms or static electricity are usually caused by improper grounding.

The sensor masses are internally connected and can be exchanged as needed.

Control output (0 – 10V / PWM)

This output is intended for the speed control of the latest generation electronic pumps (PWM) or for controlling the burner performance (0 - 10V). It can be operated via respective menu functions parallel to the output.

Data link (DL-Bus)

The bi-directional data link (DL-Bus) was developed for the ESR/UVR series and is only compatible with products of the Technische Alternative company. Any cable with a cross section of 0.75 mm² can be used for the data link (e.g. twin-strand) having a max. length of 30 m. For longer cables, we recommend the use of shielded cable.

Interface to PC: The data is cached via the data converter **D-LOGG** or the “Bootloader” **BL-NET** and transferred to the PC on request. An individual power pack (CAN-NT) is recommended for supplying power to the **BL-NET**!

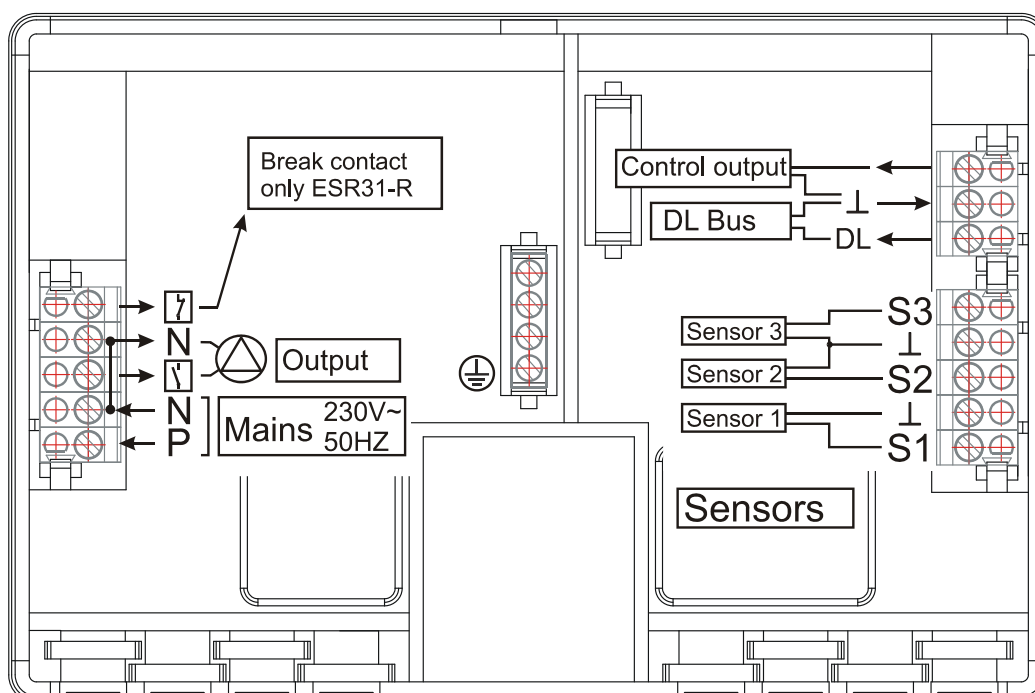

Tips on troubleshooting

In general, all of the settings in the menus **PAR** and **MEN** and the terminals should first be checked if there is a malfunction.

Malfunction, but “realistic” temperature values:

Check program number.

- ◆ Check the switch-on and switch-off thresholds and the set differential temperatures. Have the thermostat and differential thresholds already been reached?
- ◆ Were the settings in the submenus (**MEN**) changed?
- ◆ Can the output be switched on and off in manual mode? If an endurance run and standstill lead to the appropriate reaction at the output, the unit is certainly in order.
- ◆ Are all of the sensors connected with the right terminals? Heat up the sensor using a cigarette lighter and control from the display.

Incorrect display of temperature(s):

- ◆ Displayed values such as -999 if a sensor short-circuits or 999 if there is an interruption do not necessarily mean a material or terminal error. Are the right sensor types (KTY or PT1000) selected in the menu **MEN** under **SENSOR**? The factory settings set all inputs to **PT**(1000).
- ◆ The sensor can also be checked without a measuring instrument by replacing the presumed defective sensor on the strip terminal with one that works and checking the display. The resistance measured by an ohmmeter should have the following value depending on the temperature:

Temp. [°C]	0	10	20	25	30	40	50	60	70	80	90	100
R (Pt1000) [Ω]	1000	1039	1078	1097	1117	1155	1194	1232	1271	1309	1347	1385
R (KTY) [Ω]	1630	1772	1922	2000	2080	2245	2417	2597	2785	2980	3182	3392

The settings of the parameters and menu functions **ex works** can be restored any time by pressing the down arrow (enter) while plugging the machine in. The sign that appears for three seconds on the display is **WELOAD** for load factory settings.

If the system is not in operation although supply voltage is connected, the 3.15A quick-blowing fuse that protects the control system and the output should be checked and exchanged if necessary.

As the programs are constantly being revised and improved, there may be a difference in the numbering of the sensor, pumps, and program than indicated in old documents. Only the enclosed manual (identical version number) applies for the equipment supplied. The version for the manual should correspond to the equipment version.

If the control system is found to be malfunctioning despite the checks described above, please contact your retailer or the manufacturer directly. The cause of the error can only be determined if **the table of settings is completely filled out** and, if possible, the hydraulic diagram of the system in question is provided in addition to the description of the error.

Table of settings:

If the control system fails unexpectedly, all of the settings must be repeated for initiation. In such cases, problems can be prevented by entering all of the set values in the following table. **This table must be provided in any correspondence.** Only then is a simulation possible to detect the cause of the error.

EX factory settings (ex works)

CS Controller settings

	EX	CS		EX	CS
Basic functions and values					
Equipment version			Program PR	0	
Sensor S1		°C			
Sensor S2		°C	Output	AUTO	
Sensor S3		°C			
max off ↓	65 °C	°C	max on ↑	60 °C	°C
max2 off ↓		°C	max2 on ↑		°C
min on ↑	5 °C	°C	min off ↓	0 °C	°C
min2 on ↑		°C	min2 off ↓		°C
diff on ↑	8 K	K	diff off ↓	4 K	K
diff2 on ↑	8 K	K	diff2 off ↓	4 K	K

Sensor type SENSOR (if changed)					
Sensor S1	PT1000		Average AV1	1,0 s	s
Sensor S2	PT1000		Average AV1	1,0 s	s
Sensor S3	PT1000		Average AV1	1,0 s	s

System protection functions SYS PF					
Collector excess temperature CET			Frost protection function FROST		
ON/OFF	ON		ON/OFF	OFF	
Switch-off temp. max ↓	130 °C	°C	Switch-on temp. min ↑	2 °C	°C
Switch-on temp. max ↑	110 °C	°C	Switch-off temp. min ↓	4 °C	°C

Start function STARTF					
ON/OFF	OFF				
Radiation sensor GBS	--		Radiation value RTH	150W	W
Pump run-time PRT	15 s	s	Interval time INT	20 min	min

After-running time ART					
AT	0 s	s			

Pump speed control PSC (only ESR31-D)					
Abs.value control AC	--		Desired value DVA	50 °C	°C
Diff. control system DC	--		Desired value DVD	10 K	K
Event control syst. EC	--		Desired value TVE	60 °C	°C
			Desired value DVE	130 °C	°C
Proportional part PRO	5				
Integral part INT	0				
Differential part DIF	0				
Min. speed MIN	0		Max. speed MAX	30	
Delay time ALV	0				

	EX	CS		EX	CS
Control output 0-10V/PWM COP					
OFF/5V/0-10V/PWM	OFF		Output OP	--	
Abs.value control AC	--		Desired value DVA	50°C	°C
Diff. control system DC	--		Desired value DVD	10 K	K
Event control syst. EC	--		Desired value TVE	60°C	°C
			Desired value DVE	110°C	°C
Proportional part PRO	5				
Integral part INT	0				
Differential part DIF	0				
Min. analogue stage MIN	0		Max. analogue stage MAX	100	

Function check F CHCK					
ON/OFF	OFF				

Heat quantity counter HQC					
ON/OFF	OFF				
Feed sensor SSL	S1		Return sensor SRL	S2	
Vol.flow encoder VSG	--				
Litres pro pulse LPP	0,5		Volume flow V	50 l/h	l/h
Share of antifreeze SA	0%	%			

External sensors EXT DL					
External value E1	--		External value E2	--	
External value E3	--		External value E4	--	
External value E5	--		External value E6	--	

Technical data

Power supply: 210 ... 250V~ 50-60 Hz

Power input: max. 3 VA

Fuse: 3.15 A fast-acting (device + output)

Supply cable: 3x 1mm² H05VV-F conforming to EN 60730-1

Case: plastic: ABS, flame resistance: Class V0 to UL94 Norm

Protection rating: 2 - safety insulated

Protection class: IP40

Dimensions (W/H/D): 152x101x48 mm

Weight: 210 g

Allowed ambient temperature: 0 to 45° C

Inputs: 3 inputs; optional for temperature sensor (KTY (2 k Ω), PT1000), Vortex sensor VFS2-40, radiation sensor; as digital input or as input for volume flow encoder (ONLY input 3)

Control output: 0 - 10V / 20mA switchable to PWM (10V / 500 Hz), supply for electronic volume flow encoder: +5 V DC / 5 mA or connection of the auxiliary relay HIREL31-STAG

Output: 1 output

ESR31-R ... relay output

ESR31-D ... Triac output (minimum load of 20W required)

Rated current load: max. 1.5 A ohmic inductive cos phi 0.6 for ESR31-D
max. 2.5 A ohmic inductive cos phi 0.6 for ESR31-R

Tank sensor BF: diameter 6 mm incl. 2 m cable

BF PT1000 – to 90°C continuous load

BF KTY – to 90°C continuous load

Collector sensor KF: diameter 6 mm incl. 2 m cable with connection box and overvoltage protection KF KTY to 180°C continuous load KF PT1000 to 180°C continuous load (momentary to 240°C)

The sensor cables at the inputs having a cross section of 0.75 mm² can be extended by up to 30 m.

Consumers (e.g.: pumps, valves...) having a cross section of 0.75 mm² can be connected at a distance of up to 30 m.

Temperature differential: adjustable from 0 to 99°C

Minimum threshold/Maximum threshold: adjustable from -30 to +150°C

Temperature display: -40 to 200°C

Resolution: from -40 to 99.9°C in 0.1°C increments; from 100 to 200°C in 1°C increments

Accuracy: type. +-1%

We reserve the right to make technical changes.

© 2011



TECHNISCHE ALTERNATIVE

ELEKTRONISCHE STEUERUNGSGERÄTEGESELLSCHAFT M. B. H.

A-3872 Amaliendorf, Langestraße 124

EC- DECLARATION OF CONFORMITY

Document- Nr.: / Date TA10001 / 05.05.2010
Company / Manufacturer: Technische Alternative
elektronische SteuerungsgerätegesmbH.
Address: A- 3872 Amaliendorf, Langestraße 124
Product: ESR 31
The stated above product complies with the following essential requirements:
EU requirements: 2006/95/EG Low voltage standard
2004/108/EG Electromagnetic compatibility

Employed standards:

EN 60730-1:2009 08 01 Automatic electrical controls for household and similar use -
Part 1: General requirements
EN 61000-6-3:2007 11 01 Electromagnetic compatibility (EMC) - Part 6-3: Generic
standards - Emission standard for residential, commercial
and light-industrial environments
EN 61000-6-2:2006 05 01 Electromagnetic compatibility (EMC) - Part 6-2: Generic
standards - Immunity for industrial environments
Position of CE - label: On packaging, manual and type label



Issuer: Technische Alternative
elektronische SteuerungsgerätegesmbH.
A- 3872 Amaliendorf, Langestraße 124

This declaration is submitted by:

General management

This declaration certifies the agreement with the named standards, contains however
no warranty of characteristics.
The security advices of included product documents are to be considered.

UIDNr.: ATU 17986204, Firmenbuch-Nr.: FN37578m, DVR-Nr.:1011553, ARA-Lizenz-Nr.:1996

Telefon ++43(0)2862/53635 Fax ++43(0)2862/53635-7 E-mail: mail@ta.co.at <http://www.ta.co.at>

Guarantee conditions

Note: The following guarantee conditions do not in any way limit the legal right to a guarantee, rather expand your rights as a consumer.

1. The company Technische Alternative elektronische Steuerungsgerätegesellschaft m. b. H. provides a two-year guarantee from the date of purchase by the end consumer for all the devices and parts which it sells. Defects must be reported immediately upon detection and within the guarantee period. Technical support knows the correct solution for nearly all problems. In this respect, contacting us immediately will help to avoid unnecessary expense or effort in troubleshooting.
2. The guarantee includes the free of charge repair (but not the cost of on site fault-finding, removal, refitting and shipping) of operational and material defects which impair operation. In the event that a repair is not, for reasons of cost, worthwhile according to the assessment of Technische Alternative, the goods will be replaced.
3. Not included is damage resulting from the effects of overvoltage or abnormal ambient conditions. Likewise, no guarantee liability can be accepted if the device defect is due to: transport damage for which we are not responsible, incorrect installation and assembly, incorrect use, non-observance of operating and installation instructions or incorrect maintenance.
4. The guarantee claim will expire if repairs or actions are carried out by persons who are not authorised to do so or have not been so authorised by us or if our devices are operated with spare, supplementary or accessory parts which are not considered to be original parts.
5. The defective parts must be sent to our factory with an enclosed copy of the proof of purchase and a precise description of the defect. A filled in "service advice note", which can be downloaded from our homepage www.ta.co.at, will accelerate processing. A prior clarification of the defect with our technical support is necessary.
6. Services provided under guarantee result neither in an extension of the guarantee period nor in a resetting of the guarantee period. The guarantee period for fitted parts ends with the guarantee period of the whole device.
7. Extended or other claims, especially those for compensation for damage other than to the device itself are, insofar as a liability is not legally required, excluded.

TECHNISCHE ALTERNATIVE



elektronische Steuerungsgerätegesellschaft m. b. H.

A-3872 Amaliendorf Langestraße 124

Tel ++43 (0)2862 53635

Fax ++43 (0)2862 53635 7

E-Mail: mail@ta.co.at

--- www.ta.co.at ---

© 2011