

HZR 65

Version P5.6-7 EN

Universal heating controller



Operation
Installation instructions

EN



TECHNISCHE
ALTERNATIVE

Contents:

Safety requirements	4
Maintenance	4
Generally applicable rules	5
Diagram 0: Solid fuel boiler, buffer tank, heating circuit, requirement additional heating..	6
Diagram 16: Automatic boiler, hot water tank, heating circuit, burner requirement.....	8
Diagram 32: Automatic boiler, (combined) buffer, heating circuit, burner requirement ...	10
Diagram 48: buffer, hot water tank, heating circuit, burner requirement	12
Diagram 64: Solid fuel boiler, buffer, hot water tank, heating circuit	14
Diagram 80: Solar power unit, (combined) buffer tank, heating circuit, burner requirement	17
Diagram 96: Boiler (or buffer tank), hot water tank, 2 heating circuits	20
Diagram 112: Heat pump control and requirement, heating circuit pump, solar collector	22
Diagram 128: Buffer tank, heating circuit via pre-mixed district heating pipe, switch-over valve hot water, heating requirement resp. feed pump.....	23
Diagram 144: Automatic boiler, tank, mixer for increasing return, heating circuit pump, burner requirement.....	25
Installing instructions.....	27
Installing the sensor(s)	27
Installing the unit.....	28
Electrical connection.....	28
Data line (DL)	29
Selector switch.....	30
Mod (Operating mode) - Par (Parameters).....	34
Room sensor RASPT	35
Frost protection conditions for heating circuit	35
Basic principle of heat curve	36
Setting the time switch function	37
Menu.....	39
Mixer control parameter Mr.....	40
Heating circuit pump parameter HPu.....	43
Legionella protection function LES	45
Sensor type Sen	46
After-running time PnL.....	47
Switching hystereses HSt.....	48
Pump speed control Pd1, Pd2	49
Technical Data.....	52
Table of settings	53
Instructions for troubleshooting	55

Safety requirements:



All installation and wiring work on the controller must only be carried out in a zero-volts state.

The opening, connection and commissioning of the device may only be carried out by competent personnel. In so doing, all local security requirements must be adhered to.

The device corresponds to the latest state of the art and fulfills all necessary safety conditions. It may only be used or deployed in accordance with the technical data and the safety conditions and rules listed below. When using the device, the legal and safety regulations apposite to the particular use are also to be observed.

- ▶ The device must only be installed in a dry interior room.
- ▶ It must be possible to isolate the controller from the mains using an all-pole isolating device (plug/socket or double pole isolator).
- ▶ Before starting installation or wiring work, the controller must be completely isolated from the mains voltage and protected against being switched back on. Never interchange the safety extra-low voltage connections (sensor connections) with the 230V connections. Destructive and life-threatening voltages at the device and the connected sensors may occur.
- ▶ For safety reasons, the system should only be left in manual mode when testing. In this operating mode, no maximum temperatures or sensor functions are monitored.
- ▶ Safe operation is no longer possible if the controller or connected equipment exhibits visual damage, no longer functions or has been stored for a lengthy period of time under unsuitable conditions. If this is the case, place the controller and equipment out of service and secure against unintentional use.

Maintenance:

The system does not require maintenance if handled and used properly. Use a cloth moistened with soft alcohol (such as spirit) to clean. Harsh cleaning agents and solvents such as chlorethenes or tri-gases are not admissible.

As the components relevant to accuracy are not subjected to loads if used properly, long-term deviation is very low. The unit thus cannot be adjusted. Hence, no calibration is possible.

The design characteristics of the unit must not be changed during repairs. Spare parts must correspond to the original parts used to restore the manufactured condition.

Generally applicable rules for the following diagrams:

- ◆ The hydraulic diagrams of this manual are only diagrams in principle. They do not describe or replace a professional system development. There is no guarantee for function if directly copied.
- ◆ When used for floor and/or wall heaters: Here, a safety thermostat must be used just as with conventional heater controllers. It has to switch off the heating circuit pump if there is overheating regardless of the output from the controller to prevent indirect damage from excess temperatures.
- ◆ It is necessary to set all „**Required settings**“ mentioned in the hydraulic diagrams.
- ◆ "**All programs +1** (+2, +4, +8)" indicates that the selected program number can be increased by the sum total of these numbers.
- ◆ **Example:** Diagram 16, program 19 (=16+1+2): basic function (automatic boiler, hot water tank, heating circuit, burner requirement) & boiler priority & switching the burner requirement over 2 sensors.
- ◆ The term „**heating = active**“ in the link formulas describes the conditions specified in the menu heating pumps parameters „**HPu**“ for additional release resp. blocking conditions of the heating pump and the mixer. According to the factory settings heating pump and mixer are released, when the calculated nominal flow temperature „**Vsoll**“ exceeds the minimum flow temperature „**Vmin**“.
- ◆ The factory settings cause the heating pump switch-off, when the calculated nominal flow temperature „**Vsoll**“ falls below the adjusted minimum flow temperature „**Vmin**“. The mixer will be closed, when the heating pump is switched off. The temperature threshold for frost protection mode is set to 5.0°C ex works and the mixer operating mode to outdoor temperature control (**Atr**).
- ◆ **Frost protection heating circuit:** The heating circuit pump **A1** will be switched on under certain conditions (see chapter “Frost protection conditions for heating circuit”).
- ◆ **Frost protection tanks:** According to the program the burner requirement **A5** and/or load pump **A2** will be activated when the temperature falls below frost the protection temperature at a certain sensor. Programs of diagram 64 as well as programs 112, 113, 130 and 131 have no frost protection of tanks.
- ◆ With activated legionella protection function the thermostat function of the hot water tank sensor affects the feed pump and the burner requirement.
- ◆ The potential-free output **A5** (situated in the right part of the housing below the sensor terminals) is mainly arranged for boiler requirement of fossil fuel or pellets boilers. If this output is used for controlling a pump (e.g. diagram 64), a connection between supply line (phase L) and output terminal W has to be assembled.
- ◆ In diagrams with a **holding circuit** (= burner requirement with a sensor, shut-down function with another one), the shut-down transducer is “dominant”. In other words, if improper parameters or sensor installation leads to the fulfillment of both the shut-on and shut-off conditions, the shut-off condition has priority.

Diagram 0: Solid fuel boiler, buffer tank, heating circuit, requirement additional heating

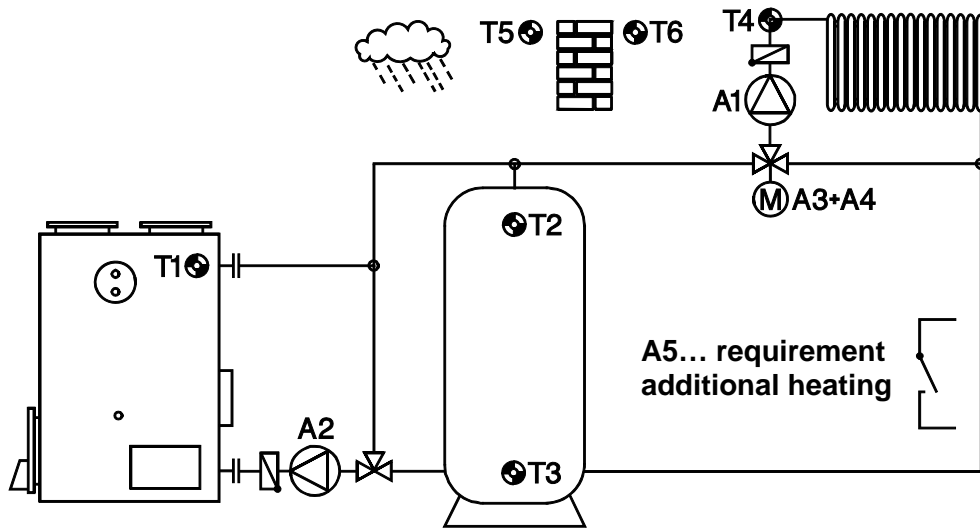

Sensors

- T1.... Boiler
- T2.... Tank top
- T3.... Tank bottom
- T4.... Heating circuit flow
- T5.... Outdoor temperature
- T6.... Room sensor

Outputs

- A1.... Heat circuit pump
- A2.... Tank feed pump
- A3.... Mixer open
- A4.... Mixer close
- A5.... Burner requirement

Basic function (P0): Release of heating circuit pump **A1** according to boiler and buffer temperature, activation of buffer feed pump **A2**, burner requirement applying to buffer.

<p>A1 off T1 < min1 and T2 < min2</p> <hr/> <p>A1 on</p> <hr/> <p>Switch-off cond. HPu A1 off</p>	<p>A2 off T1 < min1</p> <hr/> <p>diff1 A2 on</p> <hr/> <p>T3</p>	<p>Burner A5 T2 < max</p>	<p>Required settings: min1 ...switch-on thresh. T1 ⇒ A1,2 min2 ... switch-on thresh. T2 ⇒ A1 max ...burner requirement T2 ⇒ A5 diff1 ...boiler T1 – buffer T3 ⇒ A2 diff2 ...see programs 2, 3, 4, 5 Vmax, Vmin T+20, T-20 Tnorm, Tabs Mixer control parameter Mr Heating pump parameter HPu Time program</p>
--	---	---	---

$$A1 = (T1 > min1 \text{ or } T2 > min2) \& (\text{heating} = \text{active})$$

$$A2 = T1 > min1 \& T1 > T3 + diff1$$

$$A5 = T2 < max$$

Program 1: Burner requirement **A5** refers to sensor **T3**

$$A5 = T3 < max$$

Program 2: Separated switch-on and switch-off thresholds for burner requirement.

$$A5 \text{ on} = T2 < min2 + diff2$$

$$A5 \text{ off} = T2 > max$$

Program 3: as program 2, but switch-off threshold refers to **T3** (holding circuit).

$$A5 \text{ on} = T2 < min2 + diff2$$

$$A5 \text{ off} = T3 > max$$

Program 4: Burner requirement refers to nominal flow temperature "**Vsoll**".

$$A5 = T2 < Vsoll + diff2 \ \& \ (heating = active)$$

Program 5: Separated switch-on and switch-off thresholds for burner requirement. Burner requirement refers to nominal flow temperature "**Vsoll**", switch-off threshold refers to **T3** (holding circuit).

$$A5 \text{ on} = T2 < Vsoll + diff2 \ \& \ (heating = active)$$

$$A5 \text{ off} = T3 > Vsoll + diff2$$

Program 6: Separated switch-on and switch-off thresholds for burner requirement. Burner requirement refers to nominal flow temperature "**Vsoll**"

$$A5 \text{ on} = T2 < Vsoll + diff2 \ \& \ (heating = active)$$

$$A5 \text{ off} = T2 > max$$

Program 7: Separated switch-on and switch-off thresholds for burner requirement. Burner requirement refers to nominal flow temperature "**Vsoll**", switch-off threshold refers to **T3** (holding circuit).

$$A5 \text{ on} = T2 < Vsoll + diff2 \ \& \ (heating = active)$$

$$A5 \text{ off} = T3 > max$$

all programs +8: Burner requirement is only allowed, if solid fuel boiler is cold.

$$A5 (+8) = T1 < min1 \ \& \ A5$$

all programs +160: Heating circuit pump **A1** is only released by buffer tank temperature **T2** and not by boiler temperature **T1**.

$$A1 = T2 > min2 \ \& \ (heating = active)$$

Time programs are possible for heating circuit **A1** and burner requirement **A5**

Diagram 16: Automatic boiler, hot water tank, heating circuit, burner requirement

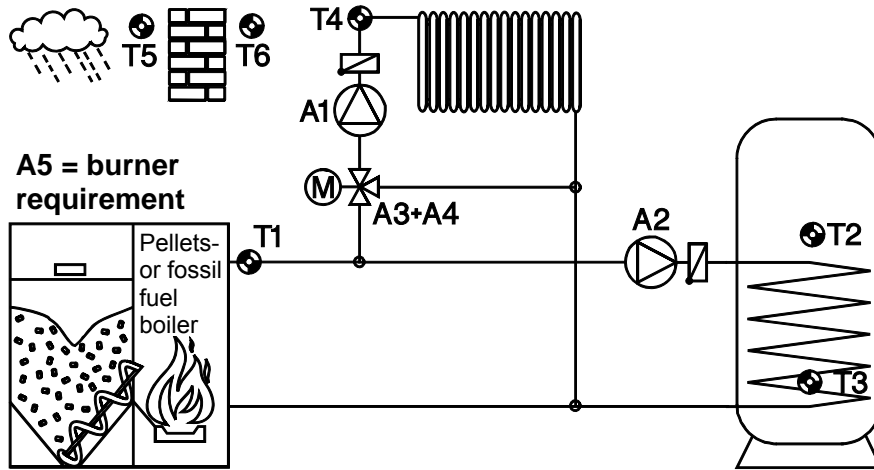

Sensors

- T1.... Boiler
- T2.... Tank top
- T3.... Tank bottom
- T4.... Heat circuit flow
- T5.... Outdoor temperature
- T6.... Room sensor

Outputs

- A1.... Heat circuit pump
- A2.... Tank feed pump
- A3.... Mixer open
- A4.... Mixer close
- A5.... Burner requirement

Basic function (P16): No buffer tank; tank feed pump = **A2**; burner requirement = **A5**.

For **sliding boiler operation without mixer**: It makes sense to set the thresholds **min1** and **min2** to 5°C (=no function) and to activate the pump switch-off condition $V_{soll} < V_{min}$ (Menu HPU).

Heating not active: Switch-off the burner requirement when nominal tank temperature **max** is reached. Tank feed pump is still active until boiler temperature falls below **min1** for discharge of the boiler residual energy.

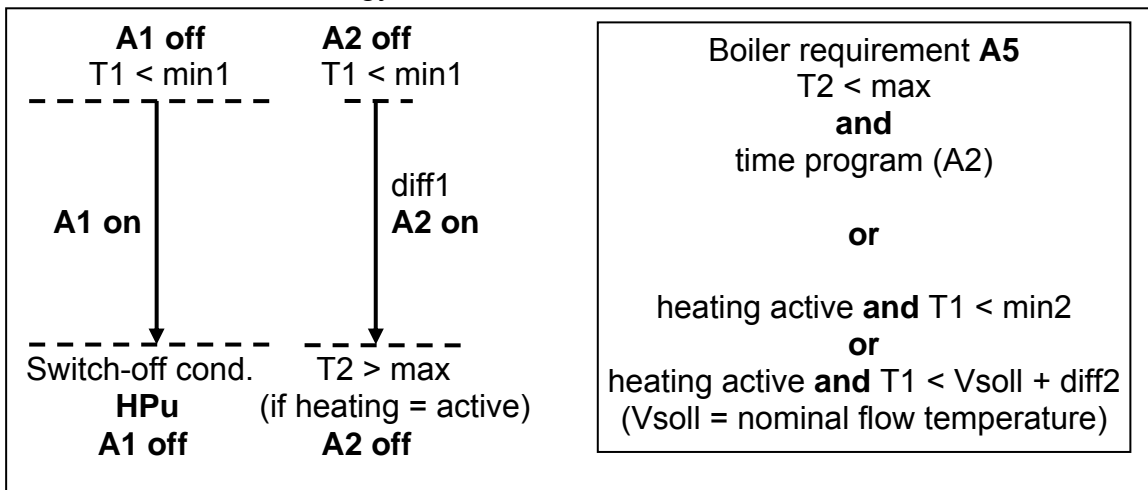

Required settings:

min1 ...switch-on thresh. T1 ⇒ **A1,2** **min2** ...switch-on thresh. T1 ⇒ **A5**
max ...limit tank T2 ⇒ **A2,5** **diff1** ...boiler T1 – tank T2 ⇒ **A2**
diff2 ...boiler T1 – V_{soll} ⇒ **A5**
Vmax, Vmin, T+20, T-20, Tnorm, Tabs, mixer control parameter Mr
heating pump parameter HPu, time program tp

$A1 = T1 > min1 \ \& \ (heating = active)$

$A2 = T1 > min1 \ \& \ T1 > T2 + diff1 \ \& \ (T2 < max \ or \ (heating = not \ active))$

$A5 = (T2 < max \ \& \ tp(A2)) \ or \ ((T1 < min2 \ or \ T1 < Vsoll + diff2) \ \& \ (heating = active))$

all programs +1: priority for hot water tank

$A1 (+1) = A1 \ only \ if \ not \ ((T2 < max) \ \& \ tp(A2))$

Together with "all Programs +2" applies:

$A1 (+3) = only \ if \ not \ ((T3 < max) \ \& \ tp(A2))$

all programs +2: Separated switch-on and switch-off thresholds for burner requirement **A5**
(holding-circuit)

$A2 = T1 > min1 \ \& \ T1 > T3 + diff1 \ \& \ (T3 < max \ or \ (heating = not \ active))$

$A5 \ on = (T2 < max \ \& \ tp(A2)) \ or \ ((T1 < min2 \ or \ T1 < Vsoll + diff2) \ \& \ (heating = active))$

$A5 \ off = (T3 > max \ \& \ tp(A2)) \ \& \ ((T1 > min2 \ \& \ T1 > Vsoll + diff2) \ \& \ (heating = active))$

all programs +4: as program 16, but feed pump function **A2** refers to **T2**

$A2 = T1 > min1 \ \& \ T1 > T2 + diff1 \ \& \ T2 < max \ (independent \ from \ heating)$

all programs +8: as program 16, but burner requirement is only referring to demand of heating circuit and tank feeding and not to comparison to boiler temperature.

$A5 = (T2 < max \ \& \ tp(A2)) \ or \ (heating = active)$

Time programs are possible for heating circuit **A1** und hot water requirement **A2**. For **A2** time program **tp(A2)** manages only on the requirement **A5** and not on the feed pump **A2**.

Diagram 32: Automatic boiler, (combined) buffer, heating circuit, burner requirement

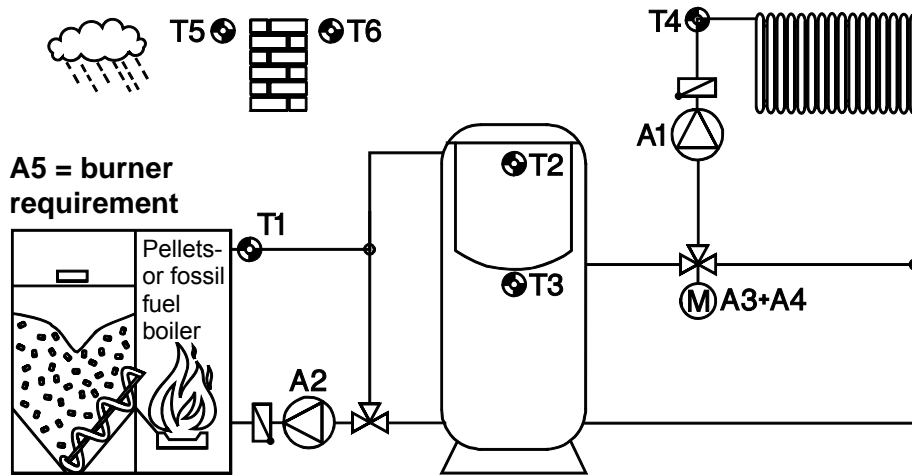

Sensors

- T1.... Boiler
- T2.... Tank top
- T3.... Tank center
- T4.... Heating circuit flow
- T5.... Outdoor temperature
- T6.... Room sensor

Outputs

- A1.... Heating circuit pump
- A2.... Tank feed pump
- A3.... Mixer open
- A4.... Mixer close
- A5.... Burner requirement

Basic function (P32): The combined tank is maintained at temperature. Tank feed pump **A2**; mixer control **A3+A4**; burner requirement **A5**. Sensor **T1** is available for eventual speed control function for boiler flow (**A2**).

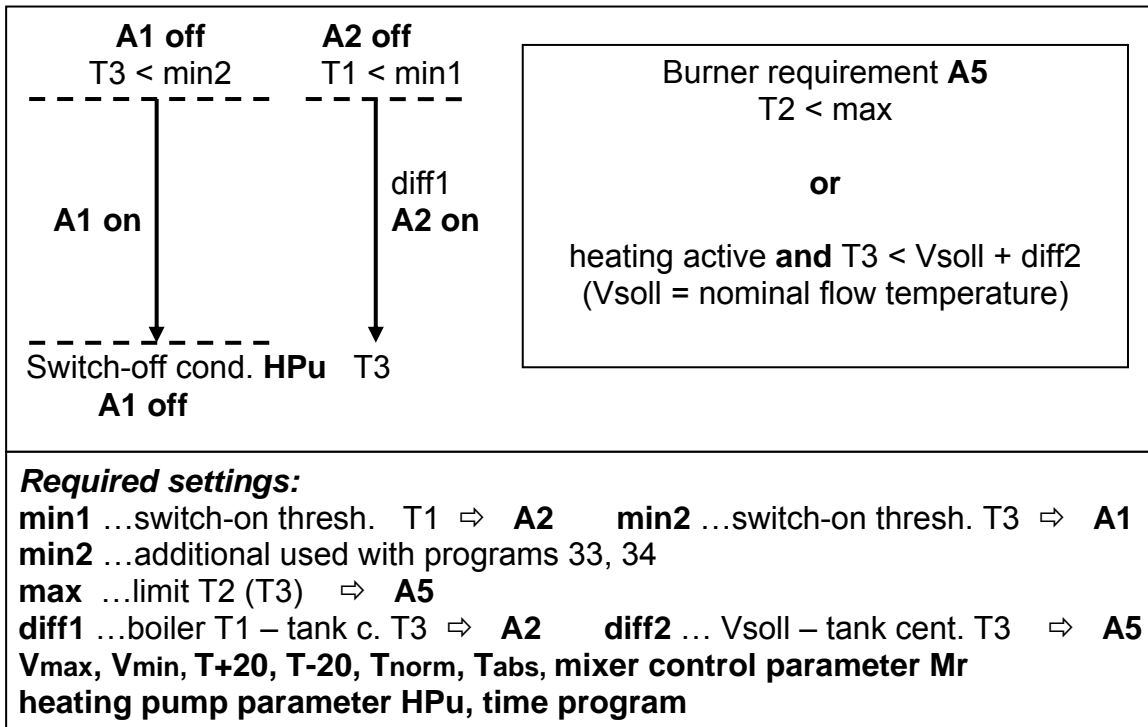

- A1 = T3 > min2 & (heating = active)**
- A2 = T1 > min1 & T1 > T3 + diff1**
- A5 = T2 < max or (T3 < Vsoll + diff2 & (heating = active))**

Program 33: Separated switch-on and switch-off thresholds for burner requirement

$$A5 \text{ on} = T2 < \min2 + \text{diff2}$$

$$A5 \text{ off} = T2 > \max$$

Program 34: as program 33, but switch-off threshold on T3 (holding-circuit).

$$A5 \text{ on} = T2 < \min2 + \text{diff2}$$

$$A5 \text{ off} = T3 > \max$$

Program 35: Holding circuit with difference on nominal flow temperature Vsoll

$$A1 = T2 > \min2 \ \& \ (\text{heating} = \text{active})$$

$$A2 = T1 > \min1 \ \& \ T1 > T3 + \text{diff1}$$

$$A5 \text{ on} = T2 < \max \ \text{or} \ (T2 < \text{Vsoll} + \text{diff1} \ \& \ (\text{heating} = \text{active}))$$

$$A5 \text{ off} = T2 > \max \ \& \ (T3 > \text{Vsoll} + \text{diff2} \ \& \ (\text{heating} = \text{active}))$$

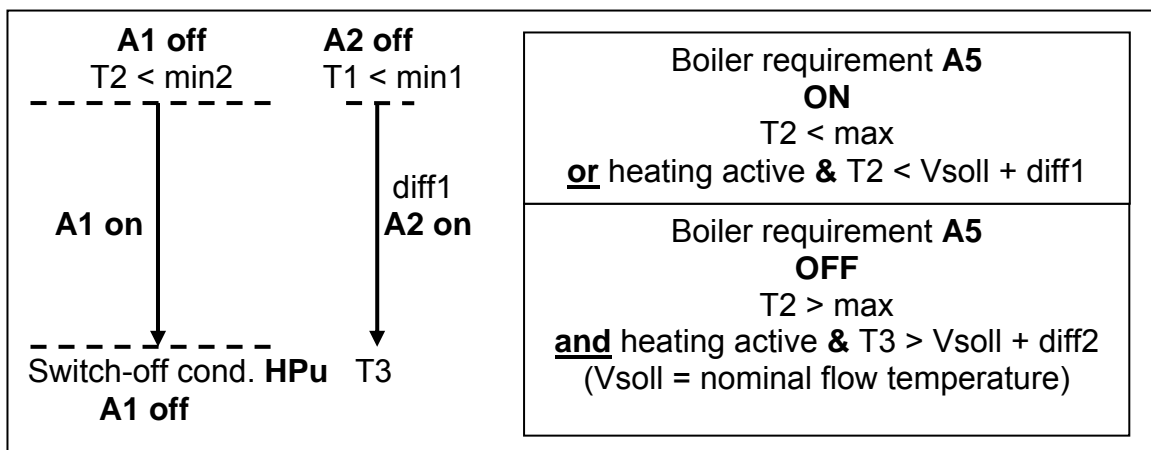

Program 36: Heating circuit pump and burner requirement are separated.

$$A1 = T2 > \min2 \ \& \ (\text{heating} = \text{active})$$

$$A2 = T1 > \min1 \ \& \ T1 > T3 + \text{diff1}$$

$$A5 = T3 < \max$$

all programs +8: Buffer feed pump A2 is switched on immediately with burner requirement (for fuel value units with minimum circulation quantity of water)

$$A2 = A2 \ \text{or} \ A5$$

Time programs are possible for heating circuit **A1** and burner requirement **A5**. For **A5** the time program manages only on the hot water requirement **A2**, because the burner requirement is linked with **A1** (heating active).

Diagram 48: buffer, hot water tank, heating circuit, burner requirement

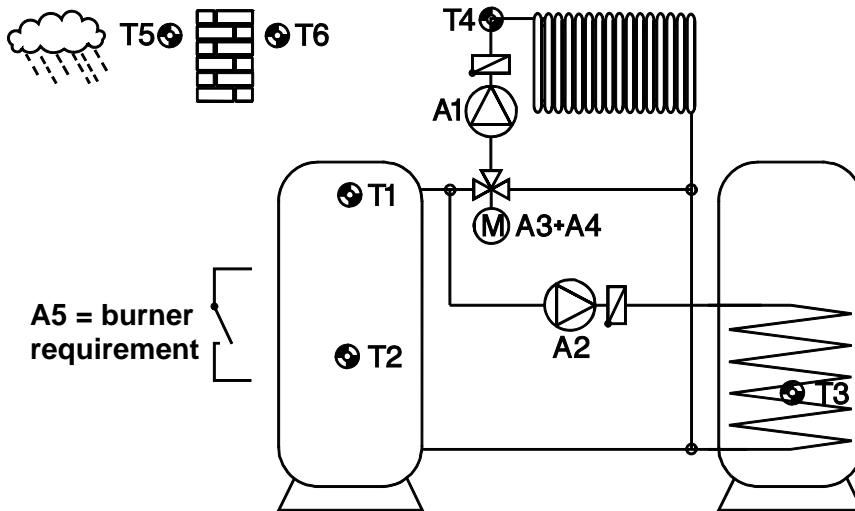

Sensors

- T1.... Buffer top
- T2.... freely useable
- T3.... Hot water tank bottom
- T4.... Heating circuit flow
- T5.... Outdoor temperature
- T6.... Room sensor

Outputs

- A1.... Heating circuit pump
- A2.... Hot water tank feed pump
- A3.... Mixer open
- A4.... Mixer close
- A5.... Burner requirement

Basic function (P48): Controlling the heating circuit pump **A1**; hot water feed pump **A2**; burner requirement **A5**

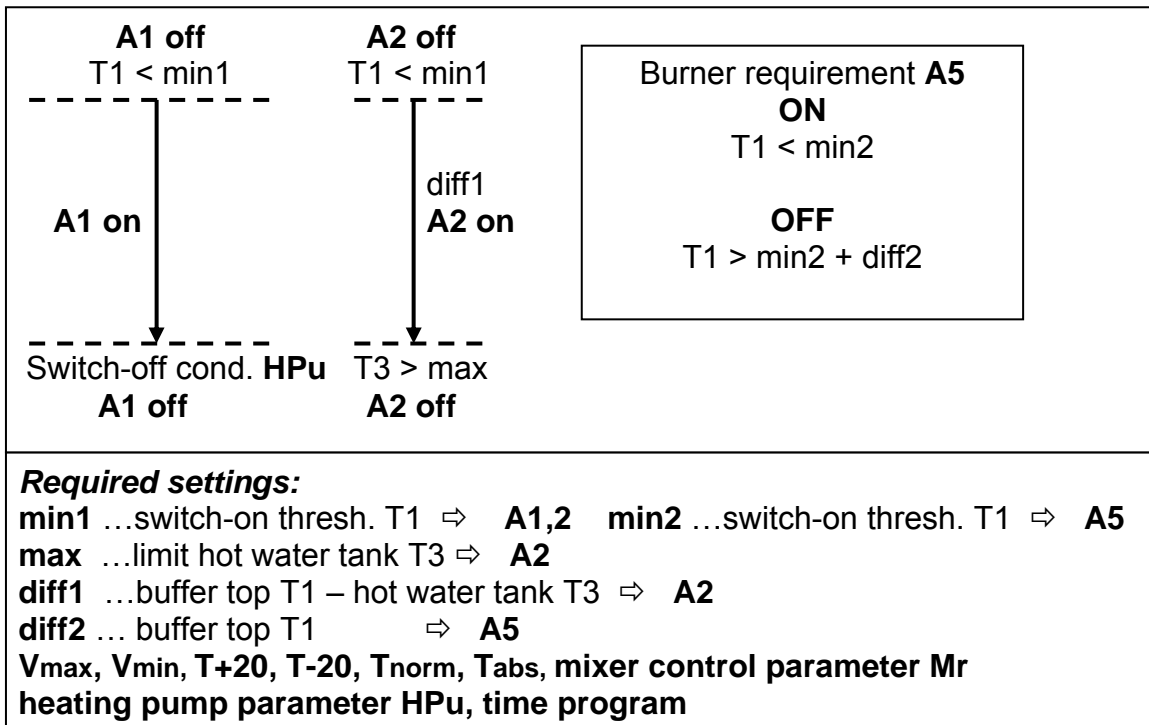

- A1 = T1 > min1 & (heating = active)**
- A2 = T1 > min1 & T1 > T3 + diff1 & T3 < max**
- A5 on = T1 < min2**
- A5 off = T1 > min2 + diff2**

Program 49: as program 48, but switch-off threshold of burner requirement on **T2** (holding-circuit)

A5 on = $T1 < min2$

A5 off = $T2 > min2 + diff2$

Program 50: Burner requirement referring to nominal flow temperature **Vsoll** and **T2**

A5 = $T2 < min2$ or $T1 < Vsoll + diff2$ & (heating = active)

Program 51: as program 50, but in consideration of hot water tank temperature **T3**

A5 = $T3 < min2$ or $T1 < Vsoll + diff2$ & (heating = active)

Program 52: separated sensors for switch-on and switch-off threshold of burner requirement (holding-circuit)

A5 on = $T1 < Vsoll + diff2$ & (heating = active)

A5 off = $T2 > min2$

Program 53: as program 52, but in consideration of the hot water tank temperature **T3** (holding-circuit)

A5 on = $T3 < max$ & ($T1 < min1$ or $T1 < T3 + diff1$)

or ($T1 < Vsoll + diff2$ & (heating = active))

A5 off = $T2 > min2$ & $T3 > max$

Program 54,55: as programs 52, 53, but **A2** (hot water) has priority to **A1**

A1 (54,55) = A1 only if not (($T3 < max$) & $tp(A2)$)

all programs +8: Second heating source besides buffer with sensor **T2**.

All conditions at **T1** apply to **T2** too. The **higher** temperature is active.

All conditions only at **T2** remain unchanged.

Example: Program 56 (=48+8)

A1 = ($T1 > min1$ or $T2 > min1$) & (heating = active)

A2 = ($T1 > min1$ or $T2 > min1$) & ($T1 > T3 + diff1$ or $T2 > T3 + diff1$) & $T3 < max$

A5 on = $T1 < min2$ and $T2 > min2$

A5 off = $T2 > min2 + diff2$ or $T1 > min2 + diff2$

Example: Program 57 (=49+8)

A1 = ($T1 > min1$ or $T2 > min1$) & (heating = active)

A2 = ($T1 > min1$ or $T2 > min1$) & ($T1 > T3 + diff1$ or $T2 > T3 + diff1$) & $T3 < max$

A5 on = $T1 < min2$ and $T2 > min2$

A5 off = $T2 > min2 + diff2$

Time programs are possible for **A1**, **A2** and **A5**. Using program 50, 51 or 53 the time program for **A5** manages only on burner requirement for hot water service.

Diagram 64: Solid fuel boiler, buffer, hot water tank, heating circuit

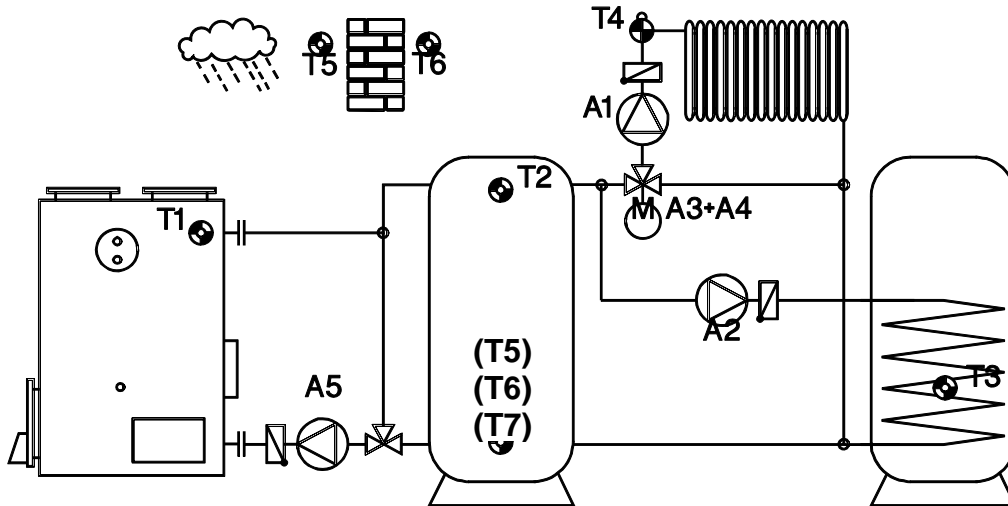

Sensors

- T1.... Boiler
- T2.... Buffer top
- T3.... Hot water tank bottom
- T4.... Heating circuit flow
- T5.... Outdoor temperature
or buffer bottom (all programs +4)
- T6.... Room sensor or buffer bottom (all programs +2)
- T7.... Buffer bottom (all programs +1)

Outputs

- A1.... Heating circuit pump
- A2..Hot water tank feed pump
- A3.... Mixer open
- A4.... Mixer close
- A5.... Buffer feed pump

Basic function (P64): Enable of heating circuit pump **A1**, when boiler or buffer tank temperature have exceeded their minimum thresholds; controlling of hot water tank feed pump **A2**; mixer control **A3 & A4**; Controlling of buffer tank feed pump **A5**.

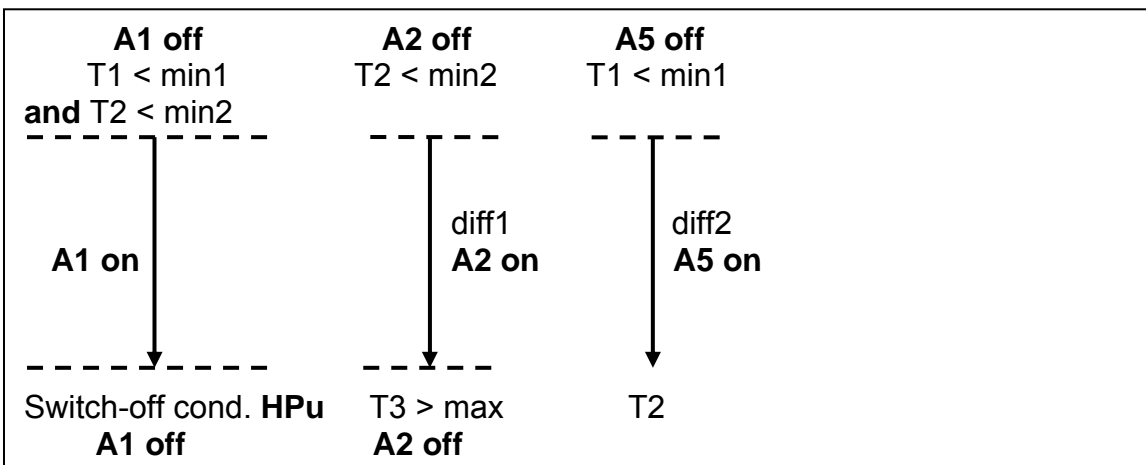

Required settings:

min1 ...switch-on thresh. T1 ⇔ **A1,5** **min2** ... switch-on thresh.T2 ⇔ **A1,2**
max ...limit hot water tank T3 ⇔ **A2**
diff1 ...buffer T2 – hw tank T3 ⇔ **A2** **diff2** ... boiler T1 - buffer T2 ⇔ **A5**
Vmax, Vmin, T+20, T-20, Tnorm, Tabs, mixer control parameter Mr
heating pump parameter HPU, time program

A1 = (T1 > min1 or T2 > min2) & (heating = active)
A2 = T2 > min2 & T2 > T3 + diff1 & T3 < max
A5 = T1 > min1 & T1 > T2 + diff2

all programs +1: Feeding the hot water tank refers to the boiler as to the buffer tank temperature.

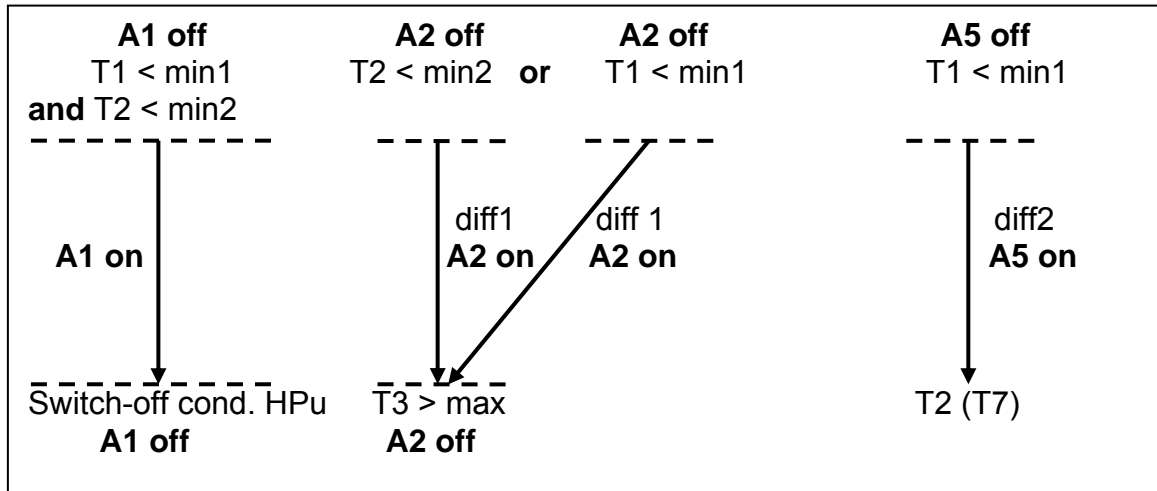

$$A2 = ((T1 > \text{min}1 \ \& \ T1 > T3 + \text{diff}1) \ \text{or} \ (T2 > \text{min}2 \ \& \ T2 > T3 + \text{diff}1)) \ \& \ T3 < \text{max}$$

Sensor 7 for all programs +1:

The function of this program variation can be optimized by a 7th sensor. The sensor **T7** must be the same sensor type as sensor **T2**, i.e. **both** sensors must be either KTY or PT1000. The controller switches over from sensor **T2** to sensor **T7** (tank bottom) when buffer feed pump **A5** is required. As no information exists about the top tank temperature at that time, it is necessary to use **program 65** (64 & 1) to make sure, that the boiler temperature **T1** has alternative information for switching hot water tank pump **A2**.

Schematic wiring diagram and operation mode:

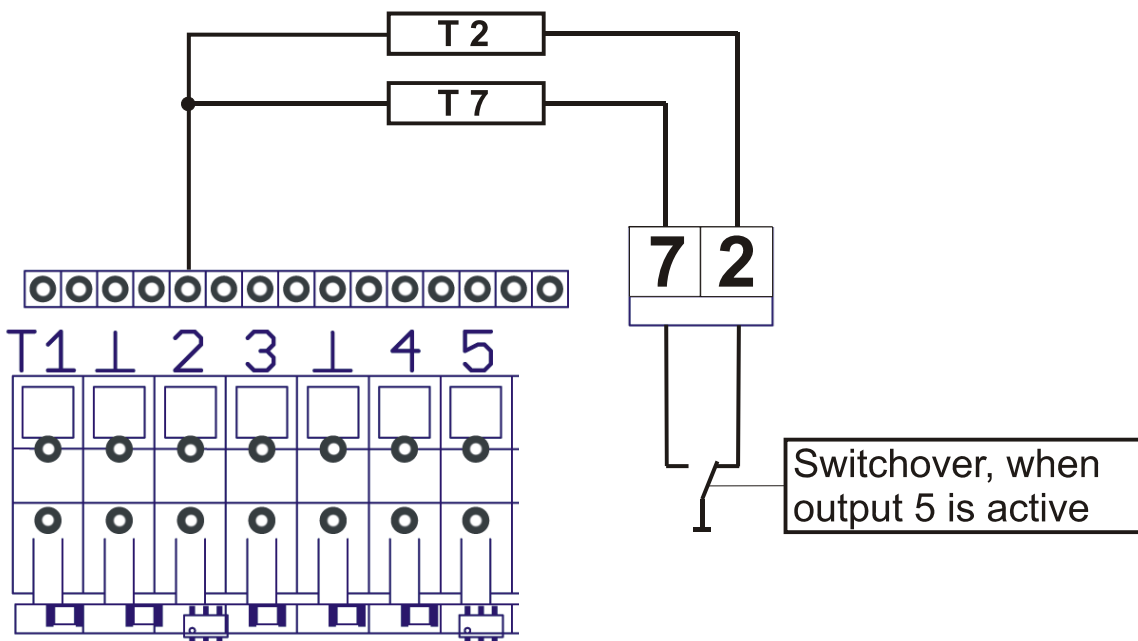

The temperature of sensor **T7** is displayed instead of sensor **T2** when output **A5** is active.

all programs +2: Sensor **T6** is not employed as room sensor, but as reference sensor for feeding buffer tank (tank bottom).

Note: **T6** must be set as standard sensor (**Std**) (see selector switch position **Mod – Par**). In position "**Par**" the use of sensor **T6** must be set:

rAS ⇒ **T6** is used as room sensor

Std ⇒ **T6** is no room sensor, frost protection at **T5** keeps active

Setting in menu mixer control parameter „**Mr**“: **Atr** = outdoor temperature control or **Fir** = fixed value control

$$A5 = T1 > min1 \ \& \ T1 > T6 + diff2$$

all programs +4: Sensor **T5** is not employed as room sensor, but as reference sensor for feeding buffer tank (tank bottom). Outdoor temperature control for heating circuit is not possible (not usable with „all programs +2).

Note: Setting in menu mixer control parameter "**Mr**": **Fir** = fixed value control, or using a room sensor **rtr** = room temperature control.

$$A5 = T1 > min1 \ \& \ T1 > T5 + diff2$$

all programs +8: Potential free contact **A5** is linked out with output **A2**.

all programs +160: Heating circuit pump is enabled only by buffer tank temperature **T2** and not by boiler temperature **T1**.

$$A1 = T2 > min2 \ \& \ (heating = active)$$

similar programs to diagram above: see program 85 and 86 (after diagram 80)

Time programs are possible for heating circuit **A1** and hot water tank feeding **A2**

Diagram 80: Solar power unit, (combined) buffer tank, heating circuit, burner requirement

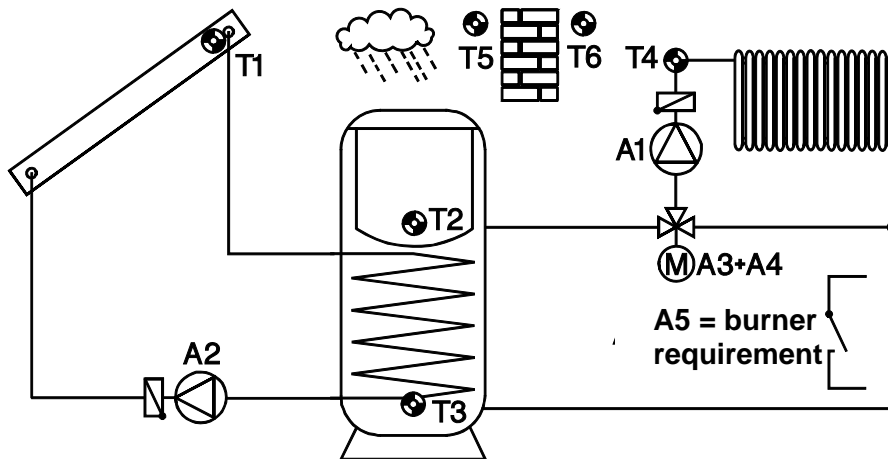

Sensors

- T1.... Collector
- T2.... Tank top
- T3.... Tank bottom
- T4.... Heating circuit flow
- T5.... Outdoor temperature
- T6.... Room sensor

Outputs

- A1.... Heating circuit pump
- A2.... Solar pump
- A3.... Mixer open
- A4.... Mixer close
- A5.... Burner requirement

Basic function (P80): Enable of heating circuit pump by minimum threshold *min1* at sensor **T2**; control of solar pump **A2** and burner requirement **A5**.

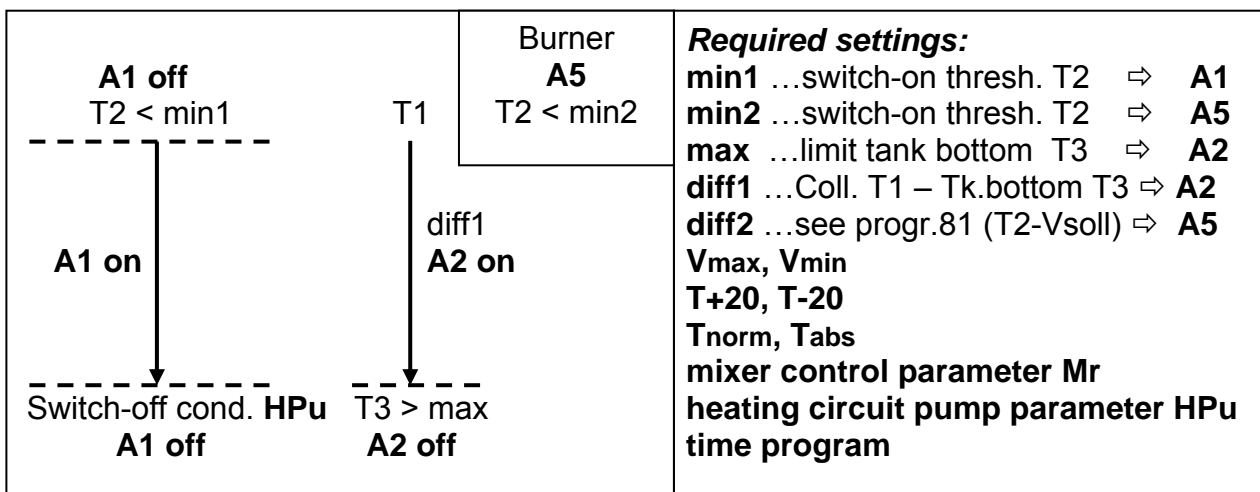

$$A1 = T2 > min1 \text{ \& (heating = active)}$$

$$A2 = T1 > T3 + diff1 \text{ \& } T3 < max$$

$$A5 = T2 < min2$$

Program 81: Burner requirement referring to nominal flow temperature **Vsoll**; time program for **A1** defines the burner requirement for heating circuit, time program linked with **A5** hot water service.

$$A5 = T2 < min2 \text{ or } (T2 < Vsoll + diff2 \text{ \& (heating = active)})$$

Program 82: Instead of burner requirement (program 80) **A5** is a hot water tank feed pump. Sensor **T6** is no room sensor, but a tank sensor. **Note:** **T6** must be set as standard sensor (**Std**) (see selector switch position **Mod – Par**). In position “**Par**” the use of sensor **T6** must be set:

rAS ⇒ **T6** is used as room sensor

Std ⇒ **T6** is no room sensor, frost protection at **T5** keeps active

Setting in menu mixer control parameter „**Mr**“: **Atr** = outdoor temperature control or **Fir** = fixed value control

$$A5 = T2 > \text{min1} \ \& \ T2 > T6 + \text{diff2} \ \& \ T6 < \text{min2}$$

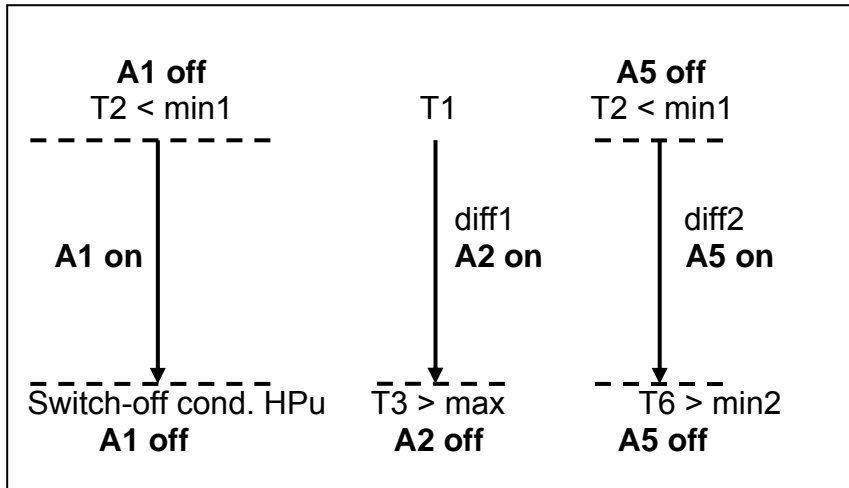

Program 83: **A5** is a hot water tank feed pump. Therefore the sensor **T6** is situated in the boiler. **Note:** **T6** must be set as standard sensor (**Std**) (see selector switch position **Mod – Par**).

Heating circuit pump **A1** is enabled by buffer tank or boiler temperature.

$$A1 = T2 > \text{min1} \ \text{or} \ T6 > \text{min2} \ \& \ (\text{heating} = \text{active})$$

$$A5 = T6 > \text{min2} \ \& \ T6 > T3 + \text{diff2}$$

Program 84: Enable of heating circuit pump **A1** without observance of any energy source temperature. **A5** is a feed pump between **T2** and **T3** without maximum threshold.

$$A1 = (\text{heating} = \text{active})$$

$$A2 = T1 > T3 + \text{diff1} \ \& \ T3 < \text{max}$$

$$A5 = T2 < \text{min2} \ \& \ (T2 > T3 + \text{diff2})$$

Program 85: A5 is a feed pump between boiler and buffer tank T2; A2 is the feed pump between boiler and hot water tank T3.

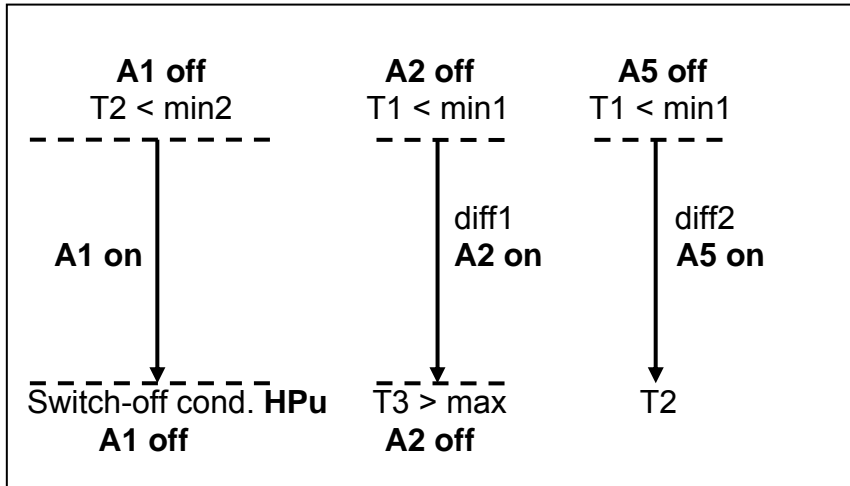

A1 = T2 > min2 & (heating = active)

A2 = T1 > min1 & T1 > T3 + diff1 & T3 < max

A5 = T1 > min1 & (T1 > T2 + diff2)

Program 86: A1 and A2 as program 85, but A5 refers to T6 (no room sensor). **Note:** T6 must be set as standard sensor (**Std**) (see selector switch position **Mod – Par**).

A5 = T1 > min1 & (T1 > T6 + diff2)

Time programs are possible for heating circuit A1, solar circuit A2 and burner requirement A5.

Diagram 96: Boiler (or buffer tank), hot water tank, 2 heating circuits

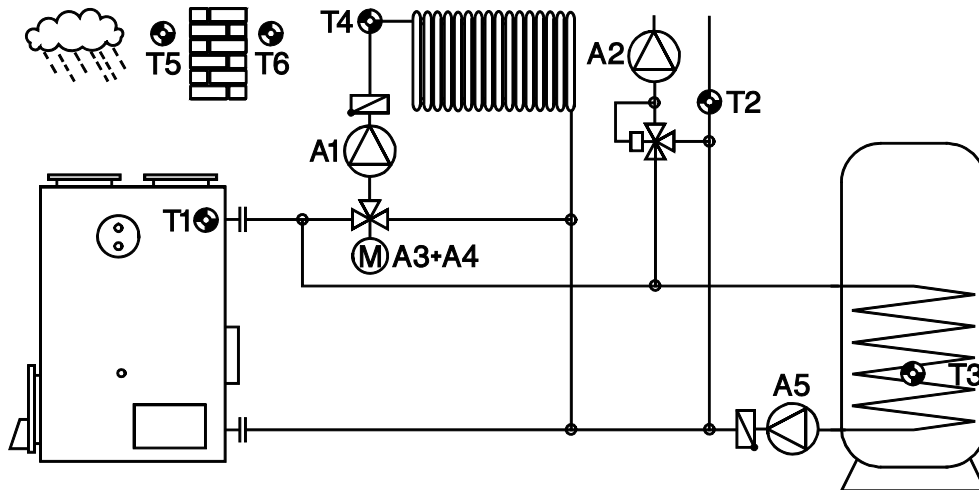

Sensors

- T1.... Boiler
- T2.... Heating circuit 2 return
- T3.... Tank bottom
- T4.... Heating circuit 1 flow
- T5.... Outdoor temperature
- T6.... Room sensor

Outputs

- A1.... Heating circuit pump 1
- A2.... Heating circuit pump 2
- A3.... Mixer open
- A4.... Mixer close
- A5.... Tank feed pump

Basic function (P96): Controlling of heating circuit pump **A1**, **A2** and hot water tank feed pump **A5**: mixer control for heating circuit 1 (**A3&A4**); controlling of the second heating circuit can be reached by absolute value control of pump speed control.

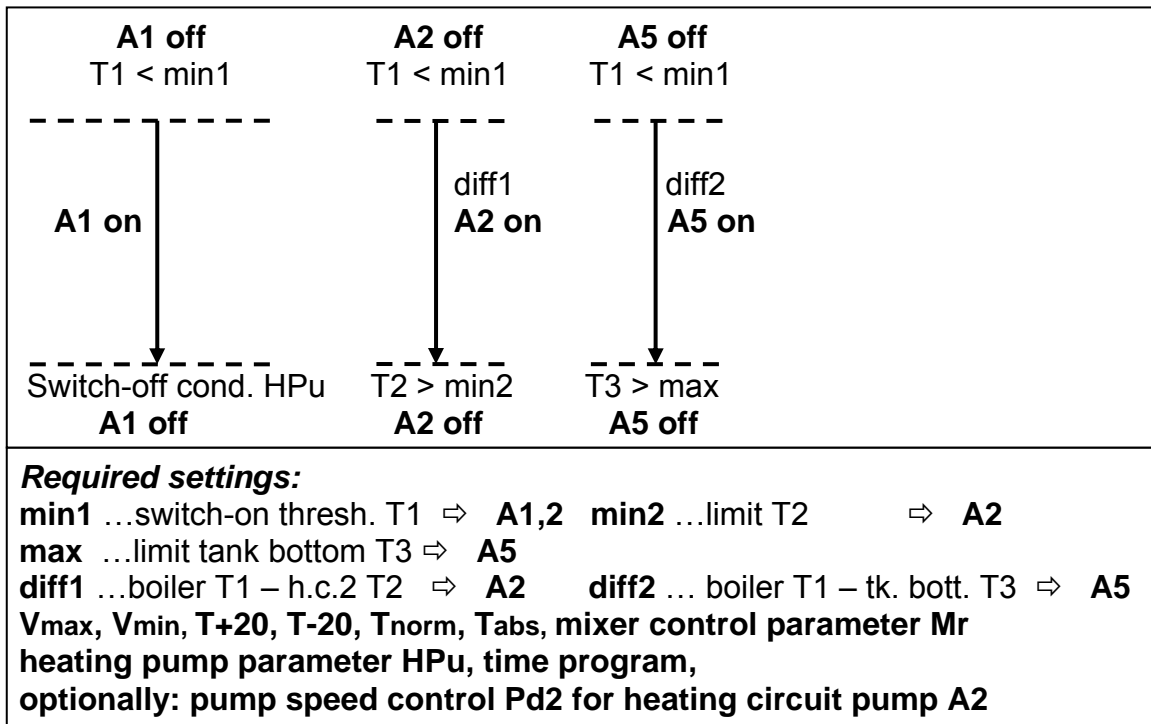

A1 = T1 > min1 & (heating = active)

A2 = T1 > min1 & T1 > T2 + diff1 & T2 < min2

A5 = T1 > min1 & T1 > T3 + diff2 & T3 < max

Program 98: Combined buffer tank instead of boiler and hot water tank. Thus output **A5** can be used for burner requirement by **T1**.

$$A5 \text{ on} = T1 < \text{max}$$

$$A5 \text{ off} = T1 > \text{max} + \text{diff2}$$

Program 100: as program 98, but switch-off threshold of burner requirement at **T3** (holding-circuit).

$$A5 \text{ on} = T1 < \text{max}$$

$$A5 \text{ off} = T3 > \text{max} + \text{diff2}$$

Program 104: as programs 98 resp. 100, but burner requirement refers to nominal flow temperature and basic temperature (hot water).

$$A5 \text{ on} = T1 < \text{max} \text{ or } T3 < \text{Vsoll} + \text{diff2} \ \& \ (\text{heating} = \text{active})$$

$$A5 \text{ off} = T1 > \text{max} \ \& \ T3 > \text{Vsoll} + \text{diff2} \ \& \ (\text{heating} = \text{active})$$

all programs +1: The heating function (heating = active) refers also to output **A2**.

$$A2 = T1 > \text{min1} \ \& \ T1 > T2 + \text{diff1} \ \& \ T2 < \text{min2} \ \& \ (\text{heating} = \text{active})$$

Time programs are possible for **A1**, **A2** and **A5**.

Diagram 112: Heat pump control and requirement, heating circuit pump, solar collector, hot water tank

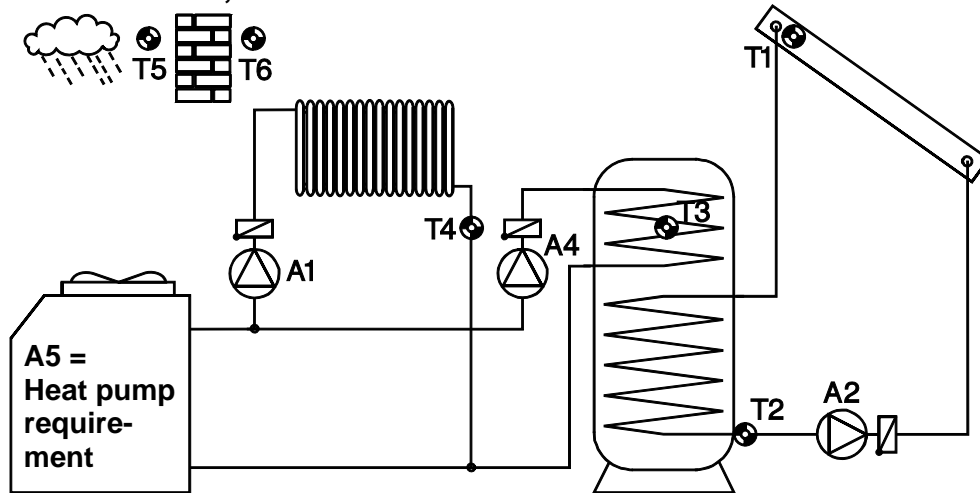

Sensors

- T1.... Collector
- T2.... Tank bottom
- T3.... Tank top
- T4.... Heating circuit return
- T5.... Outdoor temperature
- T6.... Room sensor

Outputs

- A1.... Heating circuit pump
- A2.... Solar pump
- A3.... Differential function
- A4.... Hot water tank feed pump
- A5.... Heat pump requirement

Required settings:

- min1**.... switch-on thresh. T1 ⇒ A2
- max**.... limit hot water tank T2 ⇒ A2
- diff1**.... coll. T1-tank T2 ⇒ A2
- diff2**.... switch-off thresh. return T4 - Vsoll ⇒ A5

(Vsoll = nominal flow temperature)

min2... hot water requirement T3 ⇒ A4,5

Vmax, Vmin, T+20, T-20, Tnorm, Tabs, heating pump parameter HPu, time program,

Additional settings in menu PnL (ew = factory settings "ex works"):

- Tc** cycle time setting range: 0 to 90 minutes (tc0 - tc9) ew: tc3 (30 minutes)
- Tr** run time setting range: 0 to 9 minutes (tr0 - tr9) ew: tr2 (2 minutes)
- Tb** blocking time setting range: 0 - 90 minutes (tb0 - tb9) ew: tb3 (30 minutes)

Basic function (P112): Heating circuit pump is switched on for set run time **tr** if: heating active & return temperature **T4** < **Vsoll** (nominal flow temperature depending on outdoor temperature) or set cycle time **tc** is over)

When after run time **tr** the return temperature **T4** < **Vsoll**, the heat pump is required by **A5** (condition: blocking time **tb** is over). **A1** and **A5** will be switched off, when **T4** > **Vsoll** + **diff2**.

A1 = according to description above

A2 = (T1 > min1) & (T1 > T2 + diff1) & (T2 < max)

A3 = T1 > T3 + diff2

A4 = T3 < min2

A5 = T3 < min2 or heat pump requirement for heating

Program 113: As program 112, but heating circuit pump is switched of when hot water requirement occurs (hot water priority).

Diagram 128: Buffer tank, heating circuit via pre-mixed district heating pipe, switch-over valve hot water, heating requirement resp. feed pump

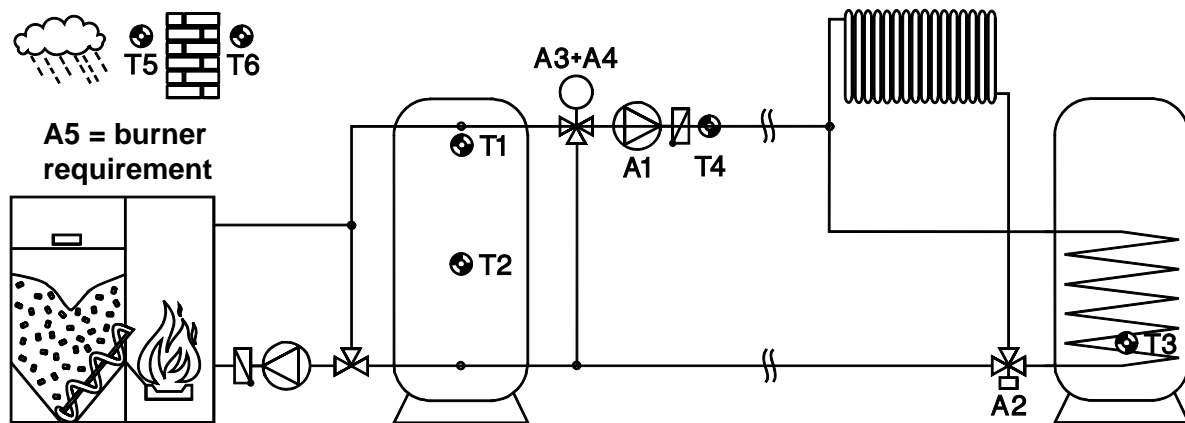

Sensors

- T1.... Buffer tank top
- T2.... Buffer tank bottom
- T3.... Hot water tank
- T4.... Heating circuit flow
- T5.... Outdoor temperature
- T6.... Room sensor

Outputs

- A1.... Heating circuit pump
- A2.... 3-way valve hot water tank
- A3.... Mixer open
- A4.... Mixer close
- A5.... Burner requirement

Basic function (P128): Heating circuit is supplied by pre-mixed district heating pipe. Heating circuit pump **A1** runs for hot water requirement too; 3-way valve **A2** opens for hot water requirement.

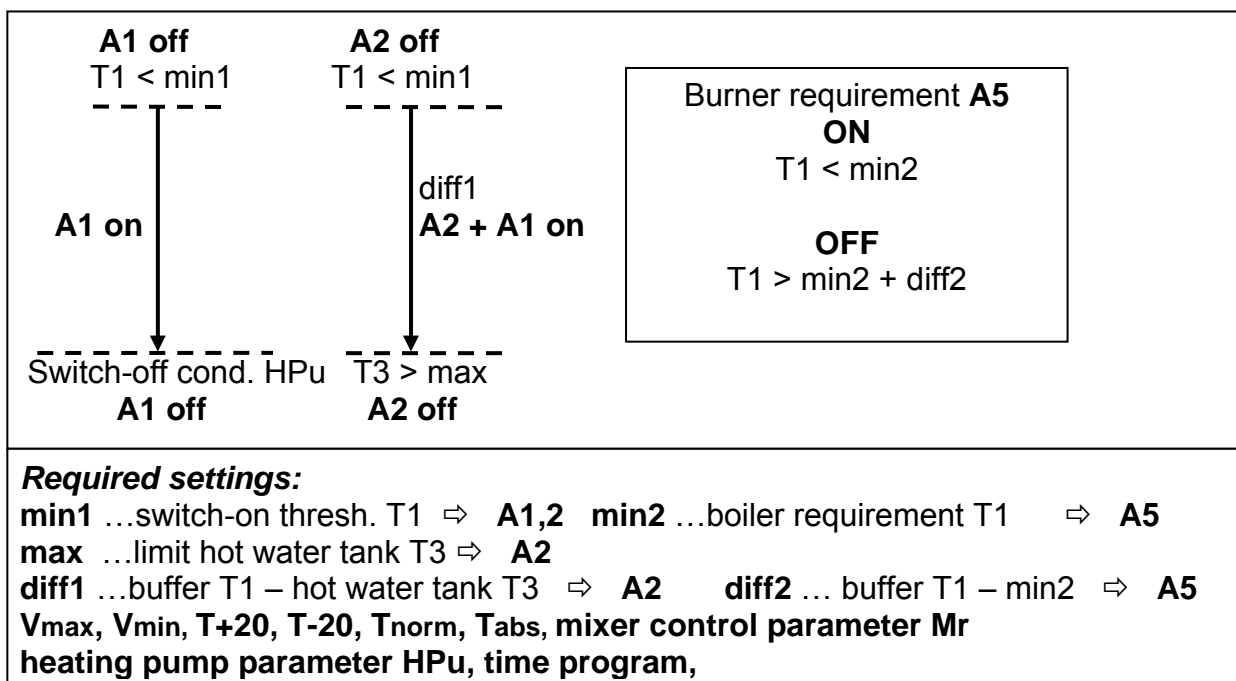

A1 = T1 > min1 & (heating = active) or A2 (hot water requirement)

A2 = T1 > min1 & T1 > T3 + diff1 & T3 < max

A5 on = T1 < min2

A5 off = T1 > min2 + diff2

Program 129: As Program 128, but switch-off threshold of burner requirement refers to **T2** (holding-circuit).

$$A5 \text{ on} = T1 < \text{min}2$$

$$A5 \text{ off} = T2 < \text{min}2 + \text{diff}2$$

Program 130: **A5** has feed pump function instead of burner requirement. Sensor **T6** is not employed as room sensor, but as tank sensor.

Note: **T6** must be set as standard sensor (**Std**) (see selector switch position **Mod – Par**). In position “**Par**” the use of sensor **T6** must be set:

rAS ⇒ **T6** is used as room sensor

Std ⇒ **T6** is no room sensor, frost protection at **T5** keeps active

Setting in menu mixer control parameter „**Mr**“: **Atr** = outdoor temperature control or **Fir** = fixed value control

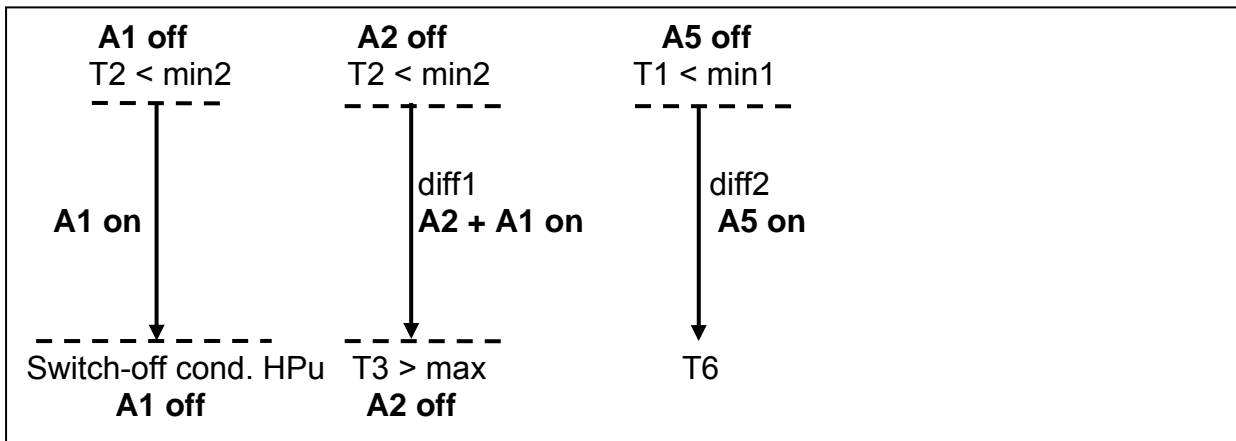

$$A1 = T2 > \text{min}2 \ \& \ (\text{heating} = \text{active}) \ \text{or} \ A2$$

$$A2 = T2 > \text{min}2 \ \& \ T2 > T3 + \text{diff}1 \ \& \ T3 < \text{max}$$

$$A5 = T1 > \text{min}1 \ \& \ T6 + \text{diff}2$$

Program 131: As program 130. Exchange of **A2** with **A5**.

$$A2 \Leftrightarrow A5$$

Diagram 144: Automatic boiler, tank, mixer for increasing return, heating circuit pump, burner requirement

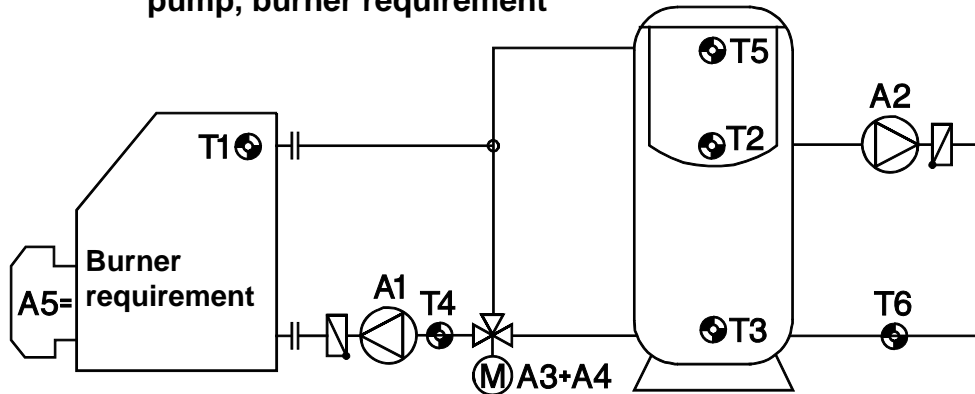

Sensors

- T1... Automatic boiler
- T2... Tank center
- T3... Tank bottom
- T4... Return line boiler
- T5... Tank top
- T6... Return heating circuit

Outputs

- A1... Feed pump
- A2... Heating circuit pump
- A3... Mixer open
- A4... Mixer close
- A5... Burner requirement

Basic function (P144): Controlling of buffer feed pump **A1** and heating circuit pump **A2**, controlling of return temperature by mixer **A3&A4**, burner requirement **A5** (holding-circuit); heating circuit control can be applied by pump speed control.

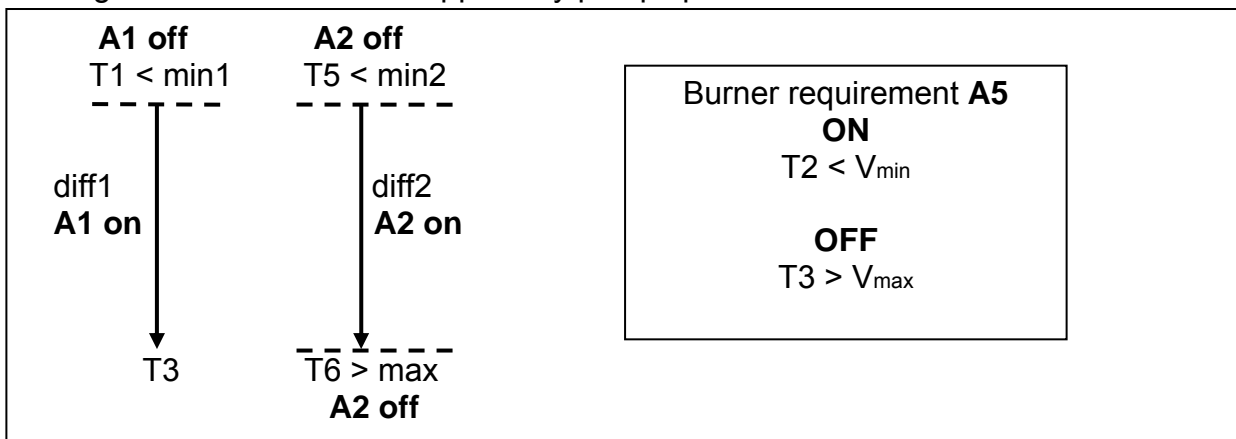

Required settings:

- min1** ...switch-on thresh. T1 ⇒ **A1**
 - min2** ...switch-on thresh. T5 ⇒ **A2**
 - max** ...heating circuit return line T6 ⇒ **A2**
 - diff1** ...boiler T1 – tank T3 ⇒ **A1**
 - diff2** ... tank T5 – heating circuit T6 ⇒ **A2**
 - Vmin** ...burner requirement on T2 ⇒ **A5**
 - Vmax** ... burner requirement off T3 ⇒ **A5**
- mixer control parameter Mr (fixed value control Fir:T+20, T-20), time program, optionally: pump speed control Pd2 for heating circuit pump A2**

$$\begin{aligned}
 A1 &= T1 > min1 \ \& \ T1 > T3 + diff1 \\
 A2 &= T5 > min2 \ \& \ T5 > T6 + diff2 \ \& \ T6 < max \\
 A5 \ on &= T2 < Vmin \\
 A5 \ off &= T3 > Vmax
 \end{aligned}$$

Program 145: Heating circuit pump is switched mainly by thermostat threshold **min2**, **T5** = outdoor temperature.

$$A2 = T2 > \text{min2} \ \& \ (\text{heating} = \text{active})$$

Program 146: As Program 144, but heating circuit pump is switched by controlled system **T2** – **T6** instead of **T5** – **T6**.

$$A2 = T2 > \text{min2} \ \& \ T2 > T6 + \text{diff2} \ \& \ T6 < \text{max}$$

Time programs are possible for **A2** and **A5**.

Installing instructions

Installing the sensor(s)

Correct arrangement and installation of the sensors is extremely important for correct functioning of the system. It should be ascertained that the sensors are completely inserted in the immersion sleeves. The threaded cable connections can serve as strain relief. Fundamentally sensors should not be exposed to moisture (such as condensation) since this can diffuse through the cast resin and damage the sensor. If this happens, heating the sensor to 90°C for an hour might help. When using immersion sleeves in NIRO tanks (inoxydable) or pools particular attention must be given to their **corrosion resistance**.

- **Boiler sensor (boiler flow):** This sensor is either screwed into the boiler using an immersion sleeve or attached to the flow line at a short distance to the boiler (see also "clip-on sensors").

- **Buffer sensor:** It is recommended to install the sensor in the upper part of the tank as a reference sensor using the immersion sleeve supplied. The best position as reference sensor for the load pump between the boiler and buffer is just above the return outlet. For tanks without a screw-in facility for the immersion sleeve the sensor can be inserted under the insulation against the wall of the tank if necessary. In this case attention should be paid to achieving a long-term secure seating (e.g. cable fastening).

- **Clip-on sensor:** Optimally secured using roll springs, pipe clamps or hose band clips to the line. Make sure the material used is suitable (corrosion, temperature resistance, etc.). Finally the sensor must be well insulated so that the exact pipe temperature is recorded without being influenced by the ambient temperature.

- **Outdoor temperature sensor:** This sensor is installed on the coldest wall (usually the north side) approx. one to two meters above ground level. Temperature influences from nearby air shafts, open windows, etc. are to be avoided.

Line extension

All of the sensor cables with a cross-section of 0.75mm² can be extended up to 30m. Beyond 30m they can be extended by use of a suitably larger cross section. The sensor and the probe can be connected by putting the heat-shrinkable tubing truncated to 4 cm over a wire and twisting the bare wire ends.

The heat-shrinkable tubing is then pushed over the twisted bare ends and carefully heated (e.g. with a lighter) until this has closed tightly around the joint.

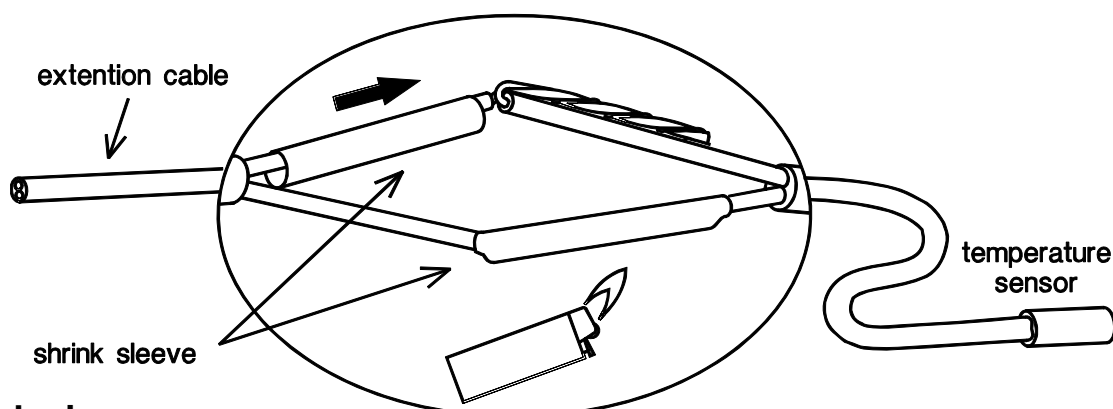

Cable laying

In order to obtain interference-free signal transmission (to avoid measurement fluctuations) the sensor lines must not be subject to interference factors. With the generally accepted use of unshielded cables sensor lines are to be laid in their own cable channel at least 20 cm away from mains cables.

Installing the unit

CAUTION! ALWAYS PULL THE MAINS PLUG BEFORE OPENING THE CASE!

Unscrew the 4 screws at the edges of the case. The controlling electronic is situated in the cover plate and is connected by a ribbon cable to the mains module, which is set in the basin of the case. The basin of the case can be screwed on through the two holes to the wall using the fastening screws provided (**with the cable bushings downwards**). For easier handling the mains module can be taken out of the case.

Electrical connection

Warning: The electrical connection should only be made by a professional electrician in accordance with the relevant local guidelines. The sensor lines may not be fed through the same cable channel as the supply voltage.

Notice: The system must be grounded to protect it from damage by lightning according to regulations; sensor failure caused by electrical storms or electrostatic charging can usually be traced to insufficient grounding.

All sensors and pumps resp. valves must be connected to the controller according to the numbering of the chosen diagram. All sensor grounds are interconnected and fully interchangeable.

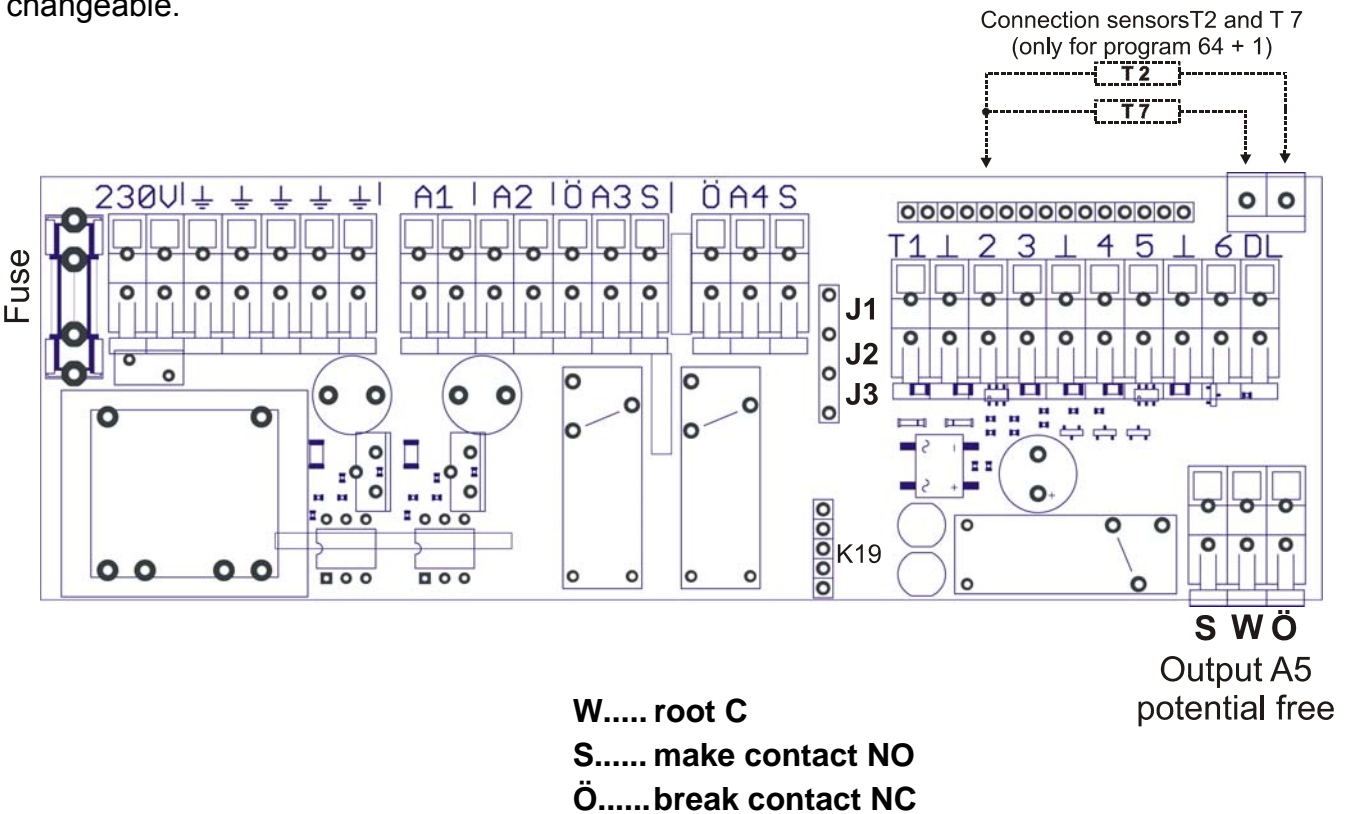

The relay output A4 can be made potential-free by setting the **jumpers** J1-J2-J3. For this purpose the jumper J2 must be set in the center instead of jumpers J1 and J3 (standard).

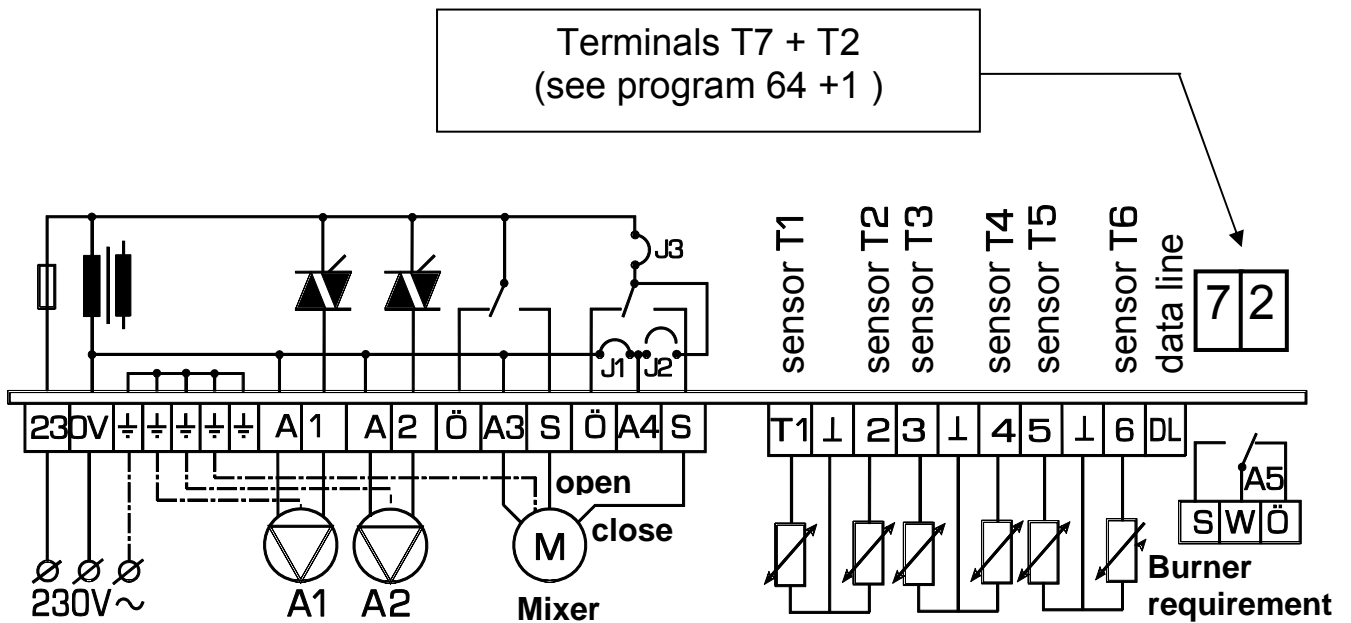

W..... root C
 S..... make contact NO
 Ö.....break contact NC

The fifth output **A5** is in the area of sensor terminals, which has a potential free switch-over contact. The connections W (root C) and S (make contact NO) are normally used for burner requirement.

Data line (DL)

The data line was specially developed for the UVR series and is only compatible with the products of Technische Alternative. It is only made for generating outputs and is suitable as interface to the PC for transferring the measured temperatures and output states.

Any cable with a cross section of 0.75 mm² can be used for the data link (e.g. twin-strand) having a max. length of 30 m. For longer cables, we recommend the use of shielded cable.

Interface to PC: The data is cached via the data converter **D-LOGG** or boot loader **BL-NET** and transferred to the PC on request. An individual power pack (CAN-NT) is necessary for supplying power to the **BL-NET**!

Selector switch

The selector switch has 16 different positions. Each position has two functions (e.g. switch position **min2 / T2**). The value, which is nearer to the selector switch, will be displayed without pressing of the yellow key "**Eingabe**" (e.g. **T2**). By pressing the yellow key "**Eingabe**" (= "input") the second value will be displayed (e.g. **min2**). The blue keys "**ab**" (= "down") resp. "**auf**" (= "up") change the settings. Holding the key pressed increases resp. decreases constantly the value, short taps cause a change of 1.

The interior legend (e.g. **T5** = displayed temperature of outdoor sensor 5) has **no direct connection** to the outside legend (e.g. **diff1** = difference between 2 sensors).

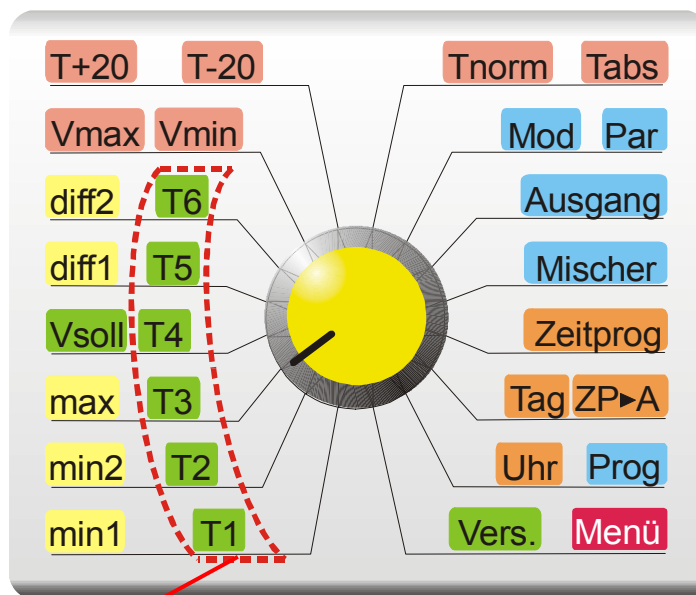

T1 - T6	Actual temperature of the sensors
min1,2	The minimal threshold min generally prevents boilers from being clogged with soot. The hysteresis has an increasing effect, i.e. reaching the threshold plus hysteresis the output will switch on, falling below the threshold it will switch off. Factory setting (ex works = ew): min1 = 60°C, min2 = 30°C; setting range: 0 to 150 °C
max	The maximum function limits the storage of tanks. The hysteresis has a decreasing effect, i.e. reaching the threshold the output will switch off, falling below the threshold minus hysteresis it will switch on again; ew : 70 °C; setting range: 0 to 150 °C
diff1,2	The output will be released, when the temperature difference between two set sensors exceeds this value. Normal set value: approx. 5K. The hysteresis has an increasing effect, i.e. reaching the temperature difference plus hysteresis the output will switch on, falling below the difference it will switch off; ew : diff1 and diff2 5.0 K; setting range: 0 to 99 K

Schematic representation of setting values:

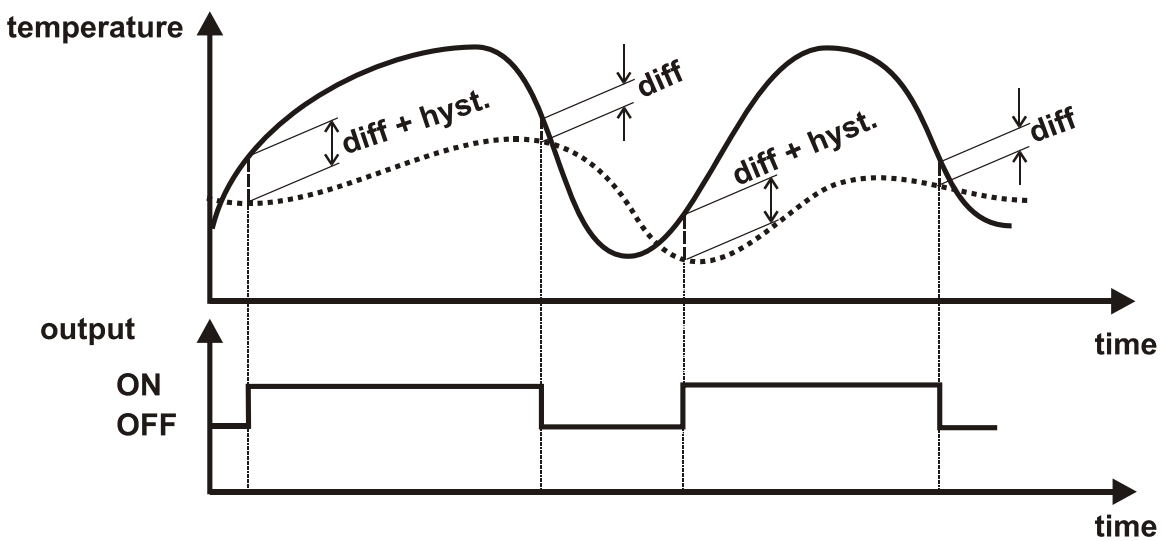
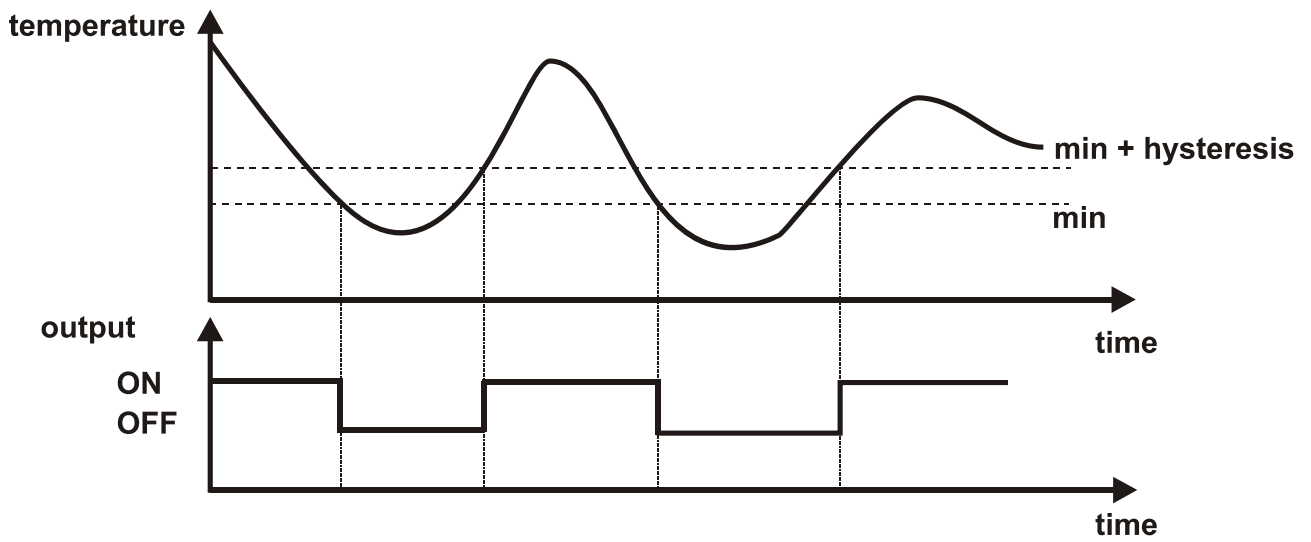
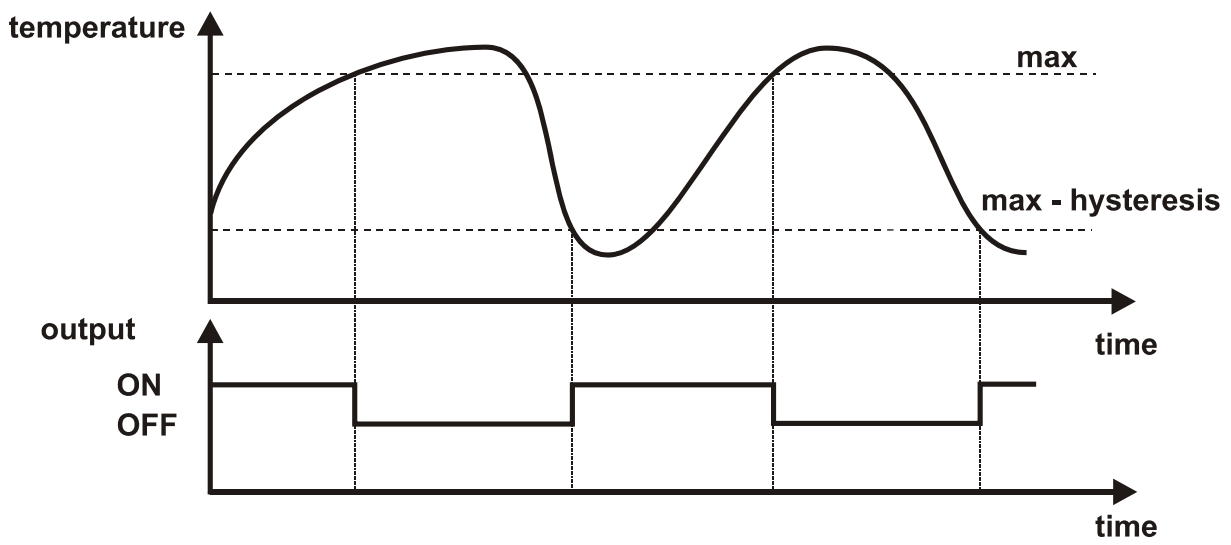

Vsoll	Nominal flow temperature, which is calculated based on measured temperatures and heating curve (not changeable check value). In normal cases it must be nearly the same value as temperature T4 (flow sensor).
Vmin	Even if the calculated nominal flow temperature is decreasing this threshold, the controller allows no lower temperature; ew = 25 °C; setting range: 0 to 99°C
Vmax	Protecting function against overheating of temperature sensitive parts (e.g. floor heating pipes); no higher temperature is allowed for mixer control; ew = 80 °C; setting range: 0 to 99°C
T-20	For complete definition of the heat curve the second value for -20°C outdoor temperature is necessary. T-20 is the necessary flow temperature at -20°C outdoor temperature; ew = 30°C; setting range: 0 to 99°C
T+20	Necessary flow temperature at outdoor temperature of +20°C for reaching the desired room temperature; ew = 70°C; setting range: 0 to 99°C
Tnorm	Desired room temperature for heating mode (heating temperature); ew = 20°C; setting range: 0 to 99°C
TabS	Desired room temperature for lowering mode (lowered temperature); ew = 15°C; setting range: 0 to 99°C
Mod	Switching over between several modes (ew = Aut): Aut – automatic mode FEI – holiday function nor – hold heating mode UrL – vacation function AbS – lowering mode Stb – standby function PAr – party function
Par	Input of parameters for functions defined under Mod .
Ausgang (=Output)	Each output can be selected by pushing the blue keys auf / ab and can be set to “ Ein ” (=On), “ Aus ” (=Off) or AUT omatic mode by pressing the keys “ Eingabe ” and auf/ab simultaneously. Attention! If an output is set to “ Ein ” (=On) or “ AUS ” (=Off), the program functions have no influence to this output.
Mischer (=Mixer)	Switching over mixer control between Automatic and „ Hand “ (=manual mode) by simultaneous pressing the keys „ Eingabe “ and “ auf ” or “ ab ”. Manual Change of mixer setting is possible with auf/ab , but after it the controller will balance the change in some minutes.
Zeitprog (=time program)	Input of time programs; this function enables – depending on the program – blocking resp. enable of outputs and for A1 switch over between heating and lowering mode of the heating function.
Tag (= day)	Actual day of the week resp. day, to which a time window is allocated at ZP⇒A.
ZP⇒A	Allocation of time program („ZP“) to outputs („A“).
Uhr (= clock)	Setting of the actual time, important for correct function of time windows. The controller has a power reserve of approx. 24 hours, i.e. when blackout longer than 24 hours occurs, time must be set again.

Prog	Selection of the program number according to the chosen diagram. The program number defines the basic function of the controller and is the most important input . Setting by the blue keys <i>ab/auf</i> (down/up); ew = P 0
Vers	In this switch position the software version of the computer is displayed (e.g. P5.6). It shows the “intelligence” of the controller and must be advertised to the manufacturer for enquiry calls. It cannot be changed.
Menü	<p>„Menü“ (= menu) allows the setting of about 50 different parameters, which are set ex works to standard settings. Sometimes it is necessary to change them. A change of these values should only be done, if the user has knowledge of all functions as these settings can change the basic features of the controller. Different parameters are stored in sub menus:</p> <ul style="list-style-type: none"> Mr..... Mixer control parameters Hpu..... Settings for heating circuit pump LES..... Legionella protection function SEn.... Sensor type – switch-over between KTY and PT1000 PnL..... After-running time Hst..... Hysteresis - setting of the hystereses for exact balancing of the system Pd1, 2... Pump speed control for outputs A1 and A2

The settings of the **menu functions ex works** can be restored at any time using the yellow key (“**Eingabe**” = entry) when plugging the unit in.

The settings of **all the parameters and menu functions ex works** can be restored at any time using both blue keys (“**ab/auf**” = up/down) when plugging the unit in.

Mod (Operating mode) - Par (Parameters)

The different operating modes refer *exclusively to mixer control and heating circuit pump*. All other outputs are still controlled according to program and setting in all operating modes. That concerns the standby function as well.

Automatic mode „Aut”

Automatic mode switches over between normal heating mode and lowering mode due to the time switch function. In parameter “**Par**” the application of the sensor **T6** (room sensor or used in another way) must be set. Setting mode: Hold “**Eingabe**”, change with “**ab/auf**” key.

- Par** = **rAS** ⇨ T6 is used as room sensor RAS
- = **Std** ⇨ T6 is no room sensor, frost protection function keeps active over T5
- = **Unb** ⇨ T6 is no room sensor, no frost protection function

Normal heating mode „nor”

Normal heating mode continues. Time switch function has no influence to heating mode. No lowering mode will be activated. No selection of parameters!

Lowering mode „AbS”

In lowering mode the room temperature will be kept at the level set in adjustment “**TabS**”. No selection of parameters!

Party mode „PAr”

Party mode keeps the room temperature at the level of normal heating mode. For this case the time must be set in “**Par**”, at which the automatic mode should start again.

Note! “**PAr**” = Party operation mode, not to confuse with “**Par**” = Parameter

Holiday mode „FEI”

When selecting this function and input of number of coming public holidays in “**Par**”, the day of input will operate as Saturday and the specified number of days as Sundays. I.e. the time switch function during these days complies with these of Saturday resp. Sunday. After this time the function will be cancelled out of memory.

Vacation mode „UrI”

Setting the length of vacation in days (in “**Par**”) the room temperature will be kept during the vacation at lowering temperature (“**TabS**”). After this time the controller switches back to automatic mode and the function is cancelled out of memory.

Standby mode „Stb”

By setting standby mode the controller operates only in frost protection mode. When the outdoor temperature **T5** decreases the frost protection threshold set in “**Par**”, the heating circuit operates in lowering mode.

Room sensor RASPT

Operation mode: The room sensor **RASPT** is a special development of „Technische Alternative“ and is provided for installing in living rooms (reference room). It should not be installed near to a heating source or to a window.





It is possible to change the room temperature in heating mode in a range of approx. +/- 4°C and to select between several modes (automatic, normal, lowered and frost protection mode).

Connection: The **RASPT** has to be connected to the terminal position T6 and sensor mass (ground).

Setting: Operating with controller HZR65 the room sensor must be defined as parameter “**rAS**” in automatic mode. Only in this case the controller detects the values of the sensor.



Switching between different operating modes:

- Automatic mode 
- Normal mode 
- Lowering mode 
- Frost protection mode 
- Changing the room temperature by +/- 4°C 

Frost protection conditions for heating circuit

The frost protection limit is set in mode “**Stb**” (Standby) as parameter.

Factory setting: +5°C, setting range: 0 – 99 °C

Mode	Par - setting in mode Aut	Frost protection activation of heating-circuit pump (decreasing the frost protection limit)
Automatic/lowered/normal	rAS	only by room sensor T6, independent from outdoor sensor T5
Automatic/lowered/normal	Std	by outdoor sensor T5
Automatic/lowered/normal	Unb	no frost protection
Standby on the controller	rAS	by room sensor T6 and outdoor sensor T5
Standby on the controller	Std	by outdoor sensor T5
Standby on the controller	Unb	by outdoor sensor T5
Standby on room sensor RASPT	rAS	only by room sensor T6, independent from outdoor sensor T5
Standby on room sensor RAS (KTY)	rAS	only by outdoor sensor T5

Setting the time switch function

As soon a time program is allocated to the heating circuit output **A1** this function allows normal heating mode only **within** the switch- on and switch-off times. I.e. the function switches over between normal heating and lowered mode. This function mode acts only on heat circuit with output **A1**.

In case of the other outputs switching according to program function is only allowed within the switch-on and switch-off times which are allocated to the output (except mixer outputs).

It is possible to select up to 5 time programs with each 3 switch-on and 3 switch-off times. Beginning with selection of a switching point (P1.1 to P5.6) with blue "**ab/au**" keys it is possible to allocate a switching time to the switching point by holding the yellow "**Eingabe**" key when changing the value by pushing the blue "**ab/au**" keys (see flow chart for time program)

After setting the switching points the time programs must be allocated to outputs and days of the week (day by day Monday to Sunday or blocked for work days **WT** (Monday to Friday)).

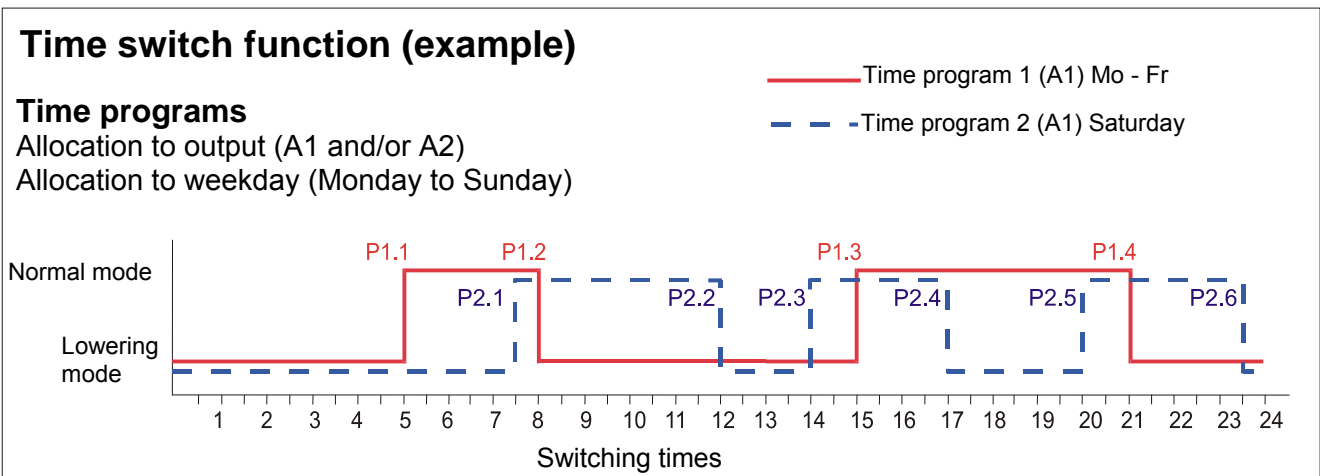

Following principles of programming switch time function have to be observed:

- ◆ The same time programs can be allocated to several outputs and/or weekdays. For this purpose in position **ZP**→**A** one day after the other must be selected (or with "**WT**" the block Monday to Friday) and a time program allocated to the desired output. If no time program is allocated to the output, the function according to the program is allowed, i.e. switch-on and switch-off according selected program with difference and thermostat function. If time windows overlap, the switch-on condition of the output will be preferred.
- ◆ After completed allocation of time windows to weekday resp. week program the actual weekday **must** be set. Only after that the menu position may be left.
- ◆ All switching points selected in "**Zeitprog**" with odd numbers (1, 3, 5) are switch-on times and all numbers with even numbers (2, 4, 6) are switch-off times.

Time program

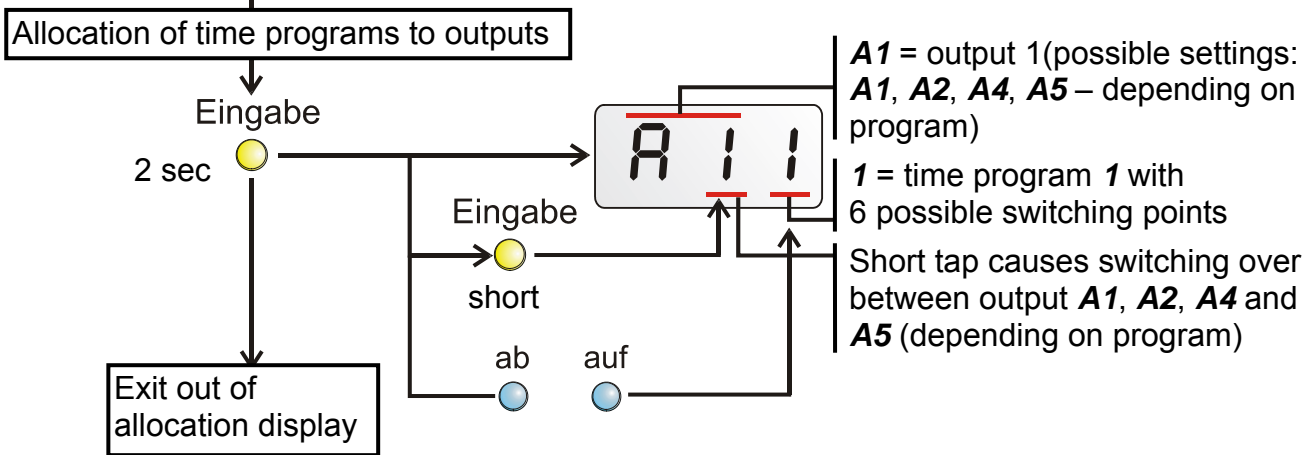
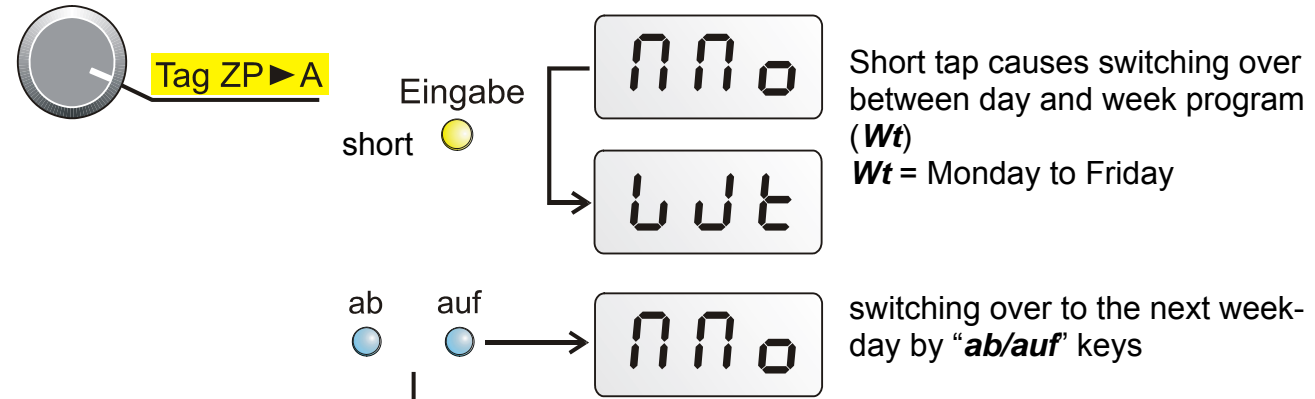
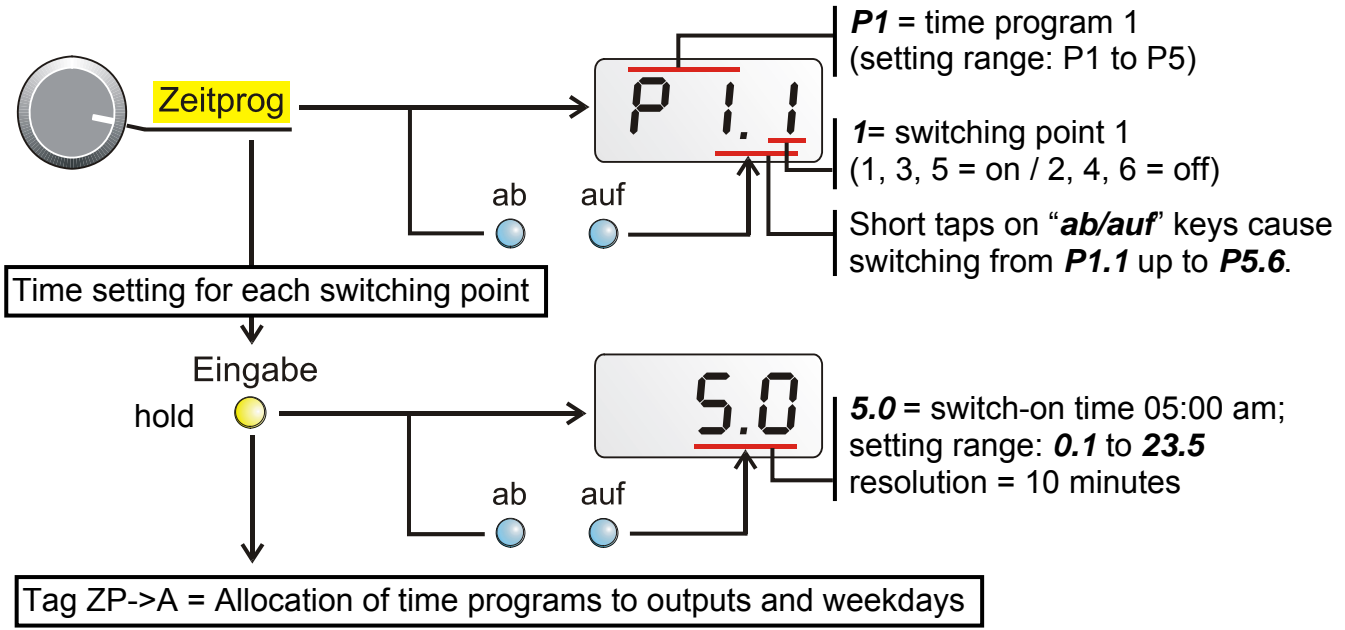

Exit from menu happens by pressing the yellow „Eingabe“ key for 2 seconds, turning the selector switch or automatically after one minute.

At the end of setting and allocation of time programs it is very important, to set the actual weekday before leaving the menu.

Menu ("Menü")

By means of sub menus („Menü“ in switching position Vers/Menü) the selection of further basic functions for optimizing the heating system is possible. These functions can change the control features radically; therefore the handling with these sub menus should be done only by experts, resp. persons, who studied this manual exactly. Not each function makes sense for each diagram resp. program.

Following sub menus are available:

- ◆ **Mr** – Mixer control parameter
- ◆ **HPu** – Heating circuit pump parameter
- ◆ **LES** – Legionella protection function
- ◆ **PnL** – After-running time
- ◆ **SEn** – Sensor type
- ◆ **HSt** – Settings of hystereses
- ◆ **Pd1** – Pump speed control for output 1
- ◆ **Pd2** – Pump speed control for output 2

Entry to menu (first menu level = main menu)

Pressing the yellow „**Eingabe**“ key for 2 seconds in switching position **Vers/Menü** causes entry to the main menu. The display shows the first sub menu "**Mr**" (= Mixer control parameter).

Advance:

A short tap on the yellow „**Eingabe**“ key switches over to the next sub menu (e.g. **HPu** = Heating circuit pump parameter)

Entry to sub menu:

Pressing the yellow „**Eingabe**“ key for 2 seconds causes entry to the sub menu. Possibility of 8 sub menus provides clear program structure.

Advance in sub menus:

Advance in the sub menu occurs by short tap on the yellow "**Eingabe**" key.

Modification:

In sub menus each value can be modified by blue „**auf/ab**“ keys.

Exit from sub menu:

Exit from sub menu happens by pressing the yellow „**Eingabe**“ key for 2 seconds.

Exit from main menu:

There are three possibilities for exit from main menu:

- ◆ by pressing the yellow „**Eingabe**“ key for 2 seconds when "**End**" is displayed;
- ◆ by turning the selector switch;
- ◆ automatically after one minute.

Restoring factory settings („ex works“):

The settings of the **menu functions** ex works can be restored at any time using the yellow "**Eingabe**" key when plugging the unit in.

Mixer control parameter Mr n n r

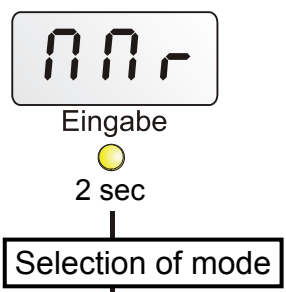

- Menu – mixer control mode
- A t r = Outdoor temperature control (factory setting, ex works=**ew**)
 - F , r = Fixed value control
 - d t r = Difference temperature control
 - A r r = Outdoor & room temperature control
 - r t r = Room temperature control

i As not all parameters are needed in all modes, only the necessary parameters are displayed.

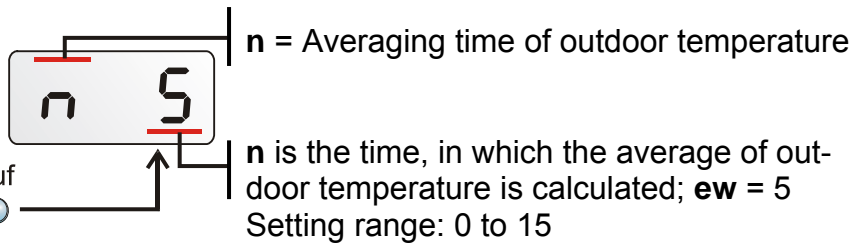
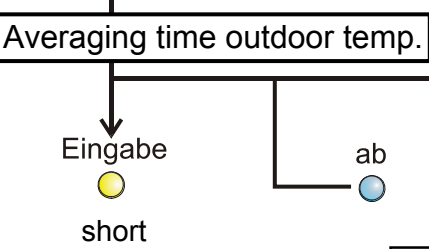
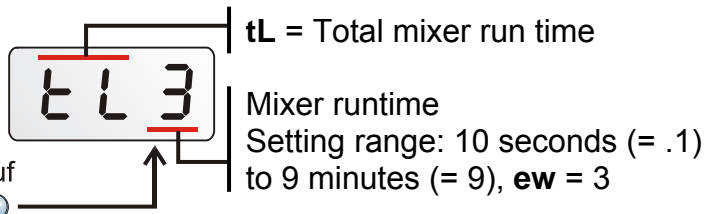
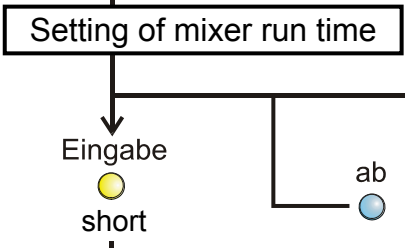

i The controller calculates the averaging time of outdoor temperature over an integration time of 2^n minutes, $n=6$ means an average time of $2^6 = 64$ minutes.

Percentage of room influence

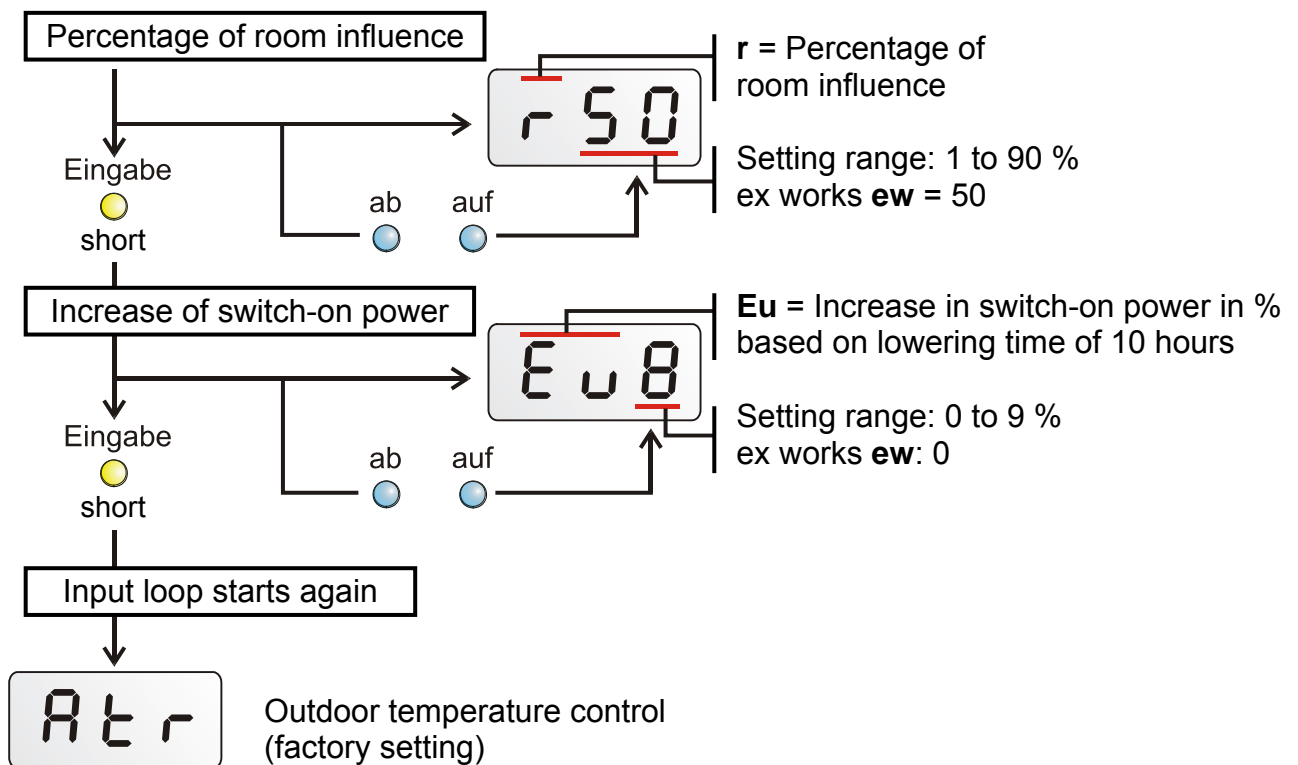

Exit from menu happens by pressing the yellow „**Eingabe**“ key for 2 seconds, turning the selector switch or automatically after one minute.

Fir - Fixed value control

In **normal heating mode** the nominal flow temperature is kept at the value set in “**T-20**” and in **lowering mode** at the value set in “**T+20**”. Switch-over occurs is based on time switch function (allocation of time windows to output **A1**).

Atr – Outdoor temperature control

The flow temperature varies between **Vmin** and **Vmax** based on the heat curve depending on outdoor temperature. Heat curve is determined by settings **T+20** and **T-20**. Switch-over occurs based on time switch function (allocation of time windows to output **A1**).

rtr – Room temperature control

In normal heating mode room temperature **Tnorm** is controlled based on set flow temperature **T-20**.

In lowering mode room temperature **Tabs** is controlled based on set flow temperature **T+20**. If the room temperature differs from **Tnorm** resp. **Tabs** the flow temperature will be calculated and modified according to the room influence factor **r**.

Switch-over between normal heating and lowering mode occurs by allocation of a time window to output **A1**.

Arr - Outdoor temperature & room temperature control

This operating mode combines the advantages of outdoor temperature control with advantages of room temperature control.

Flow temperature changes according to the heating characteristic (**T+20** and **T-20**) depending to outdoor temperature between limits **Vmin** and **Vmax**.

Flow temperature is corrected according to room influence factor **r**, when room temperature differs from **Tnorm** resp. **Tabs**.

Switch-over between normal heating and lowering mode occurs by allocation of a time window to output **A1**.

dtr – Difference temperature controlling

In this mode it is possible to keep a constant temperature difference between heating circuit flow **T4** (**Vsoll** = nominal flow temperature) and sensor **T5**. The desired constant difference between **T4** and **T5** is set by values **T+20** or **T-20**

Function:	$V_{sollr} = T5 + T_{+20} - T_{-20}$	T5 = measured value = 22°C
Example:	$V_{sollr} = 22 + 10 - 0 = 32°C$	T+20 = set value = 10K
		T-20 = set value = 0K

Application: e.g. district heating transmission station

Eu – Percentage of increase in switch-on power

Increase in switch-on power causes increasing of flow temperature depending on lowering time for shortening the heating-up period.

Function:	$V_{soll} = V_{sollr} + \frac{V_{sollr} * Z * Eu}{3060}$	Vsoll = Nominal flow temperature
		Z = Numerator is increased every 20 minutes by 1 when A1 is switched-off and is decreased by 1 every minute when A1 is switched on.
		Eu = Percentage of increase in switch-on power according to switch-off time of 10 hours.
		Vsollr = Nominal flow temperature calculated by the controller

Heating circuit pump parameter HPu HPu

These parameters cause switching-off behavior of heating circuit pump, when:

- ◆ nominal room temperature is reached;
- ◆ outdoor temperature increases threshold;
- ◆ calculated nominal flow temperature falls below **Vmin**;
- ◆ a certain sensor exceeds temperature threshold (excess temperature).

Additional mixer behavior while deactivated heating circuit pump can be set.

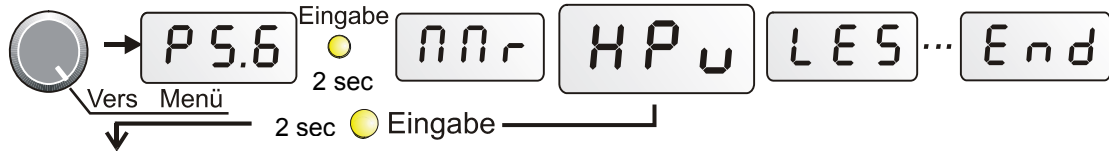

Switch-off heating circuit pump when nominal room temperature is reached

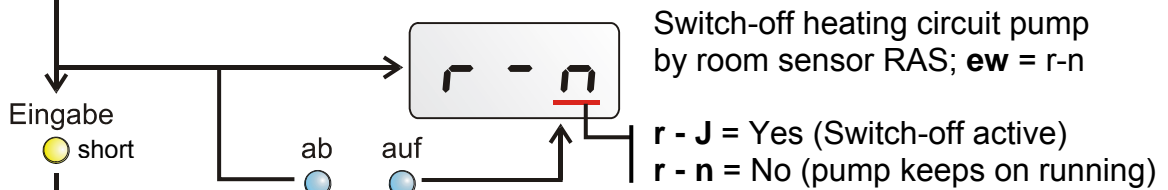

Hysteresis of room sensor when switch-off is active

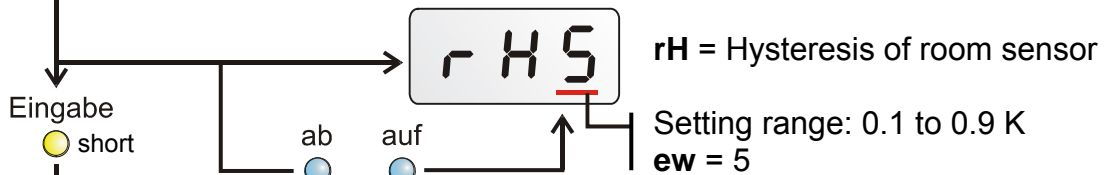

Switch-off heating pump depending on outdoor temperature

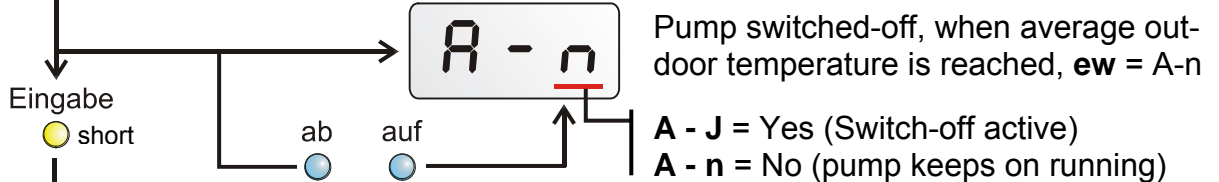

Nominal value of threshold when outdoor temperature switch-off is active

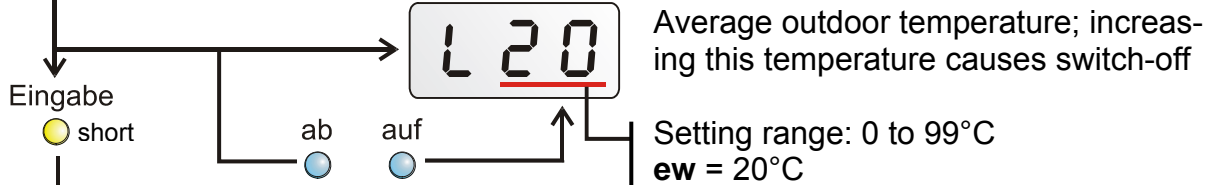

Setting of integration time for average outdoor temperature

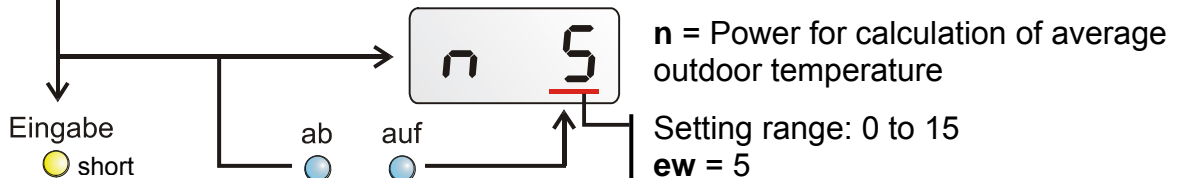

i The controller calculates the average value of outdoor temperature during integration time of 2^n minutes. $N = 5$ means, that the average value is calculated over $2^5 = 32$ minutes.

Switch-off heating pump when nominal flow temperature $V_{soll} < V_{min}$

Switch-off heating pump when nominal flow temperature $V_{soll} < V_{min}$

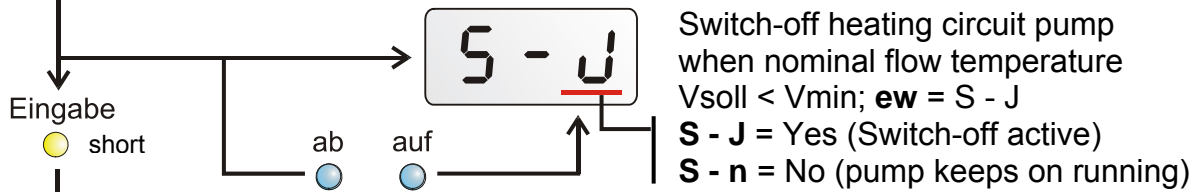

Allocation of sensor for excess temperature protection function

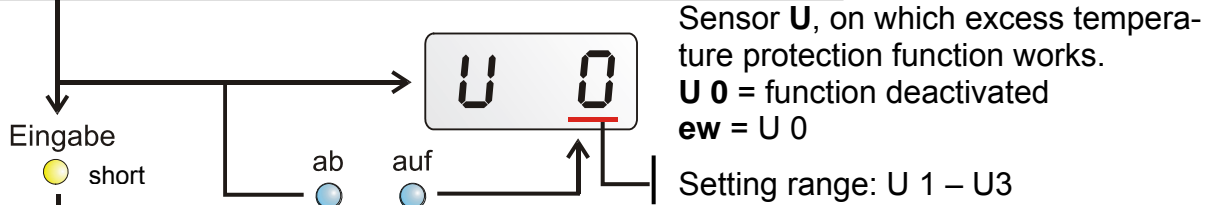

Temperature threshold for excess temperature protection function

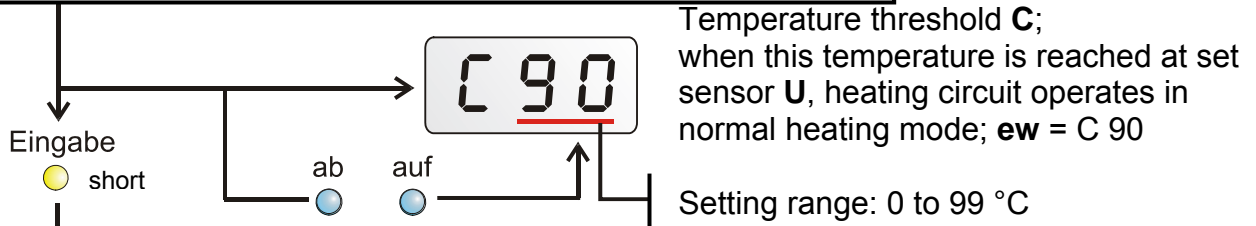

Mixer behavior when heating circuit pump is switched off

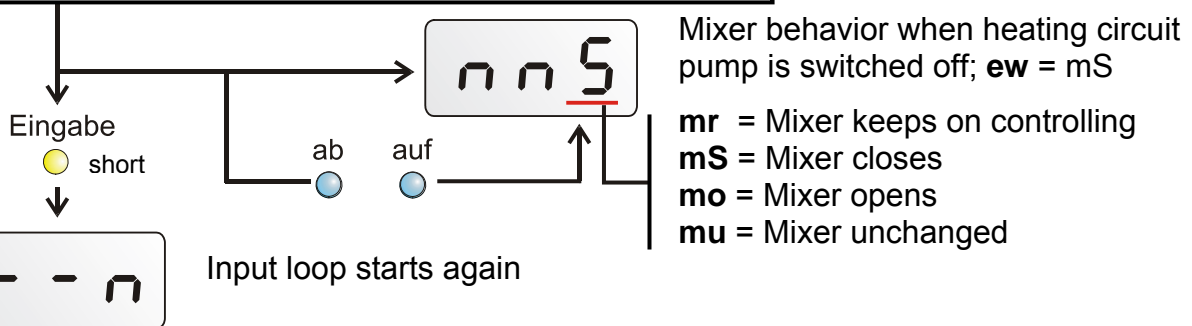

Exit from menu happens by pressing the yellow „**Eingabe**“ key for 2 seconds, turning the selector switch or automatically after one minute.

Legionella protection function LES LES

For avoiding production of legionellae this protection function can be activated. After lapse of cycle time (t_c) tank temperature is heated up to nominal temperature (C) beginning from start time (h) (depending to program).

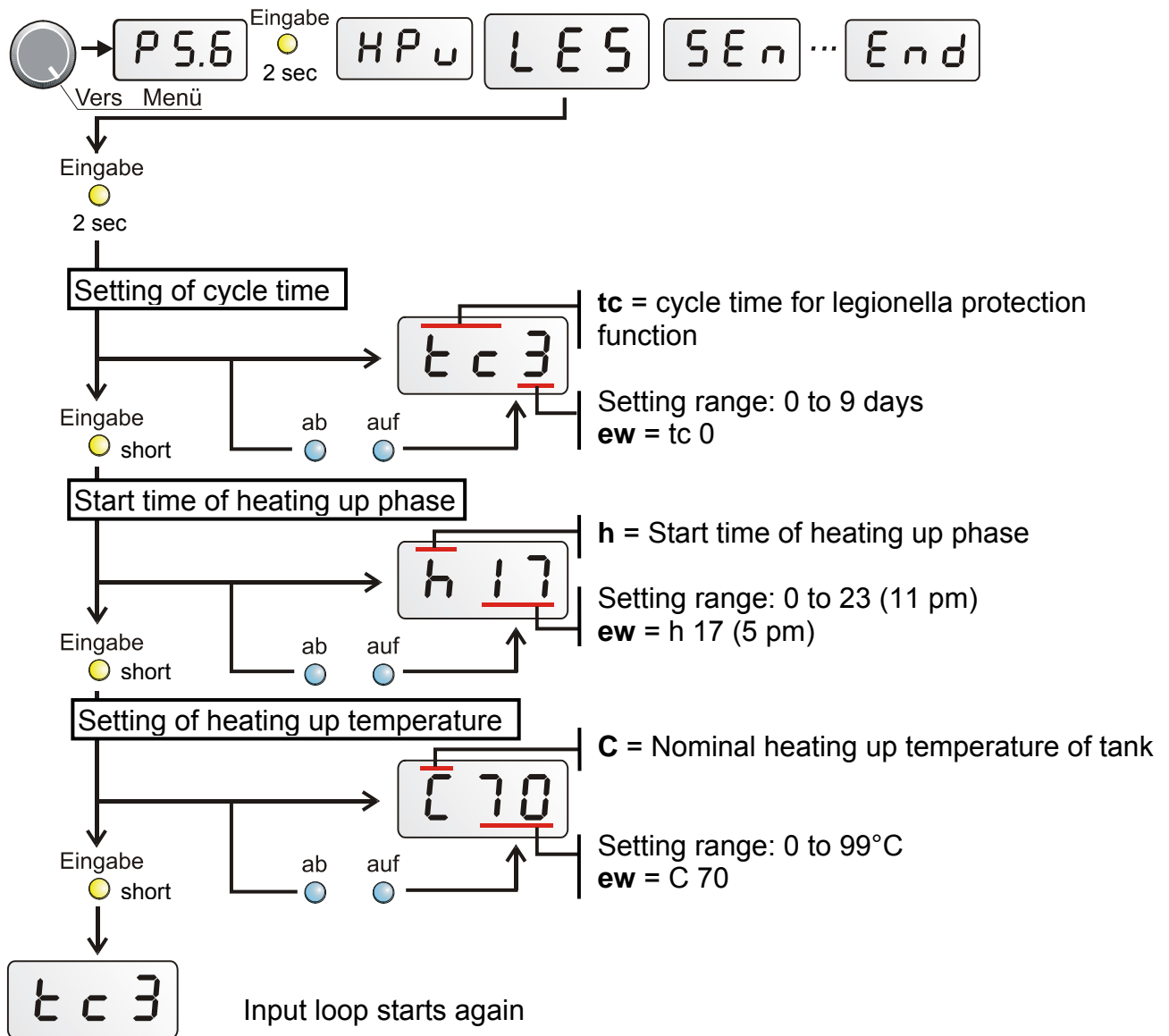

Exit from menu happens by pressing the yellow „**Eingabe**“ key for 2 seconds, turning the selector switch or automatically after one minute.

Sensor type Sen SEn

Menu **Sensor type** allows switch-over of sensors between Pt1000 and semi-conductor (KTY) types. Factory setting (ex works) of all sensors is **Pt1000 (P)**.

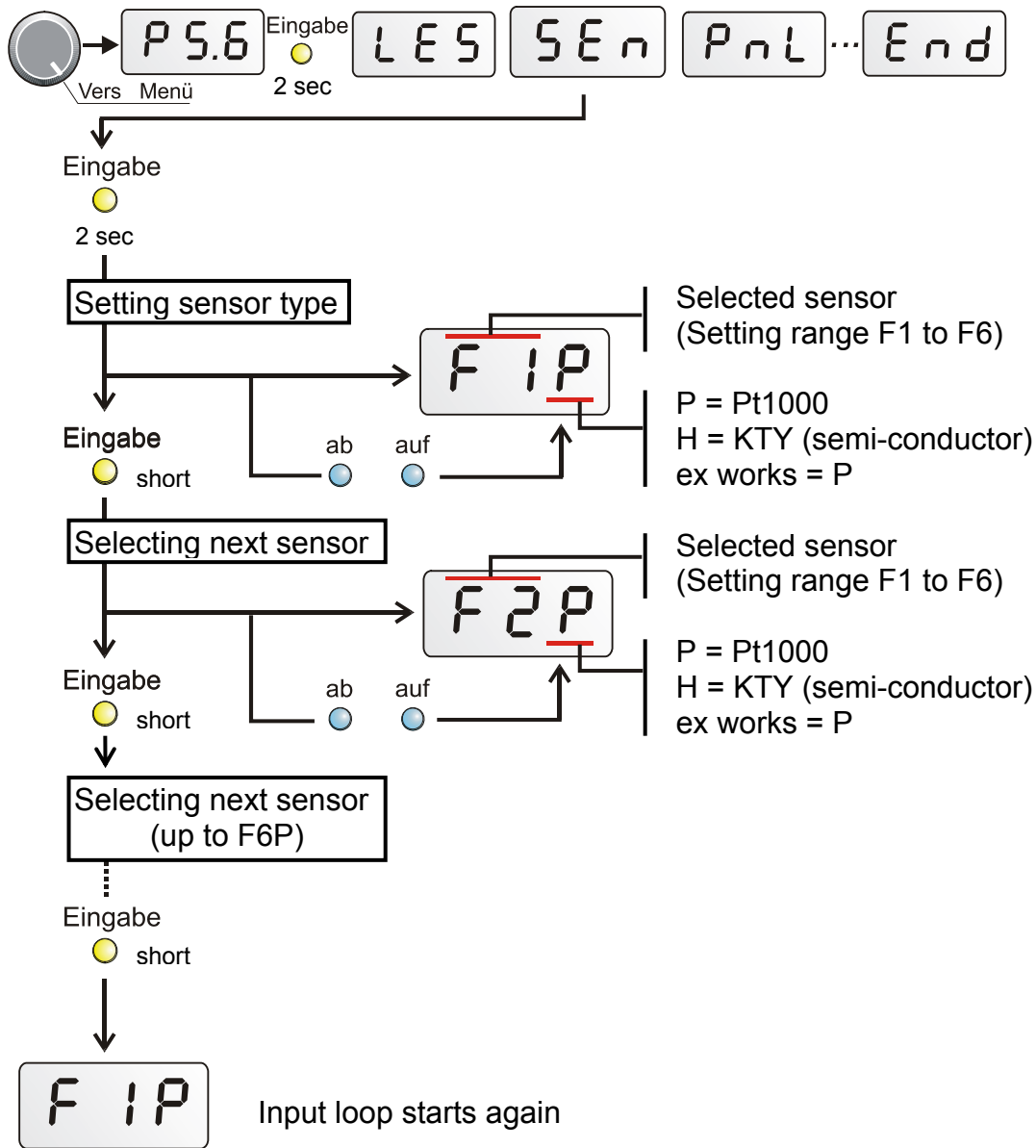

Exit from menu happens by pressing the yellow „**Eingabe**“ key for 2 seconds, turning the selector switch or automatically after one minute.

After-running time PnL P n L

During the start phase, the pumps may repeatedly switch on and off for a long time, especially with solar and heating systems with long hydraulic system lines. This response can be reduced by using a speed control or increasing the pump after-run time.

Depending on the selected program each output can be allocated an after-running time, except mixer outputs.

Example: After access to the sub menu PnL the display shows "t13". That means, the pump after-running time for output 1 is 3 minutes.

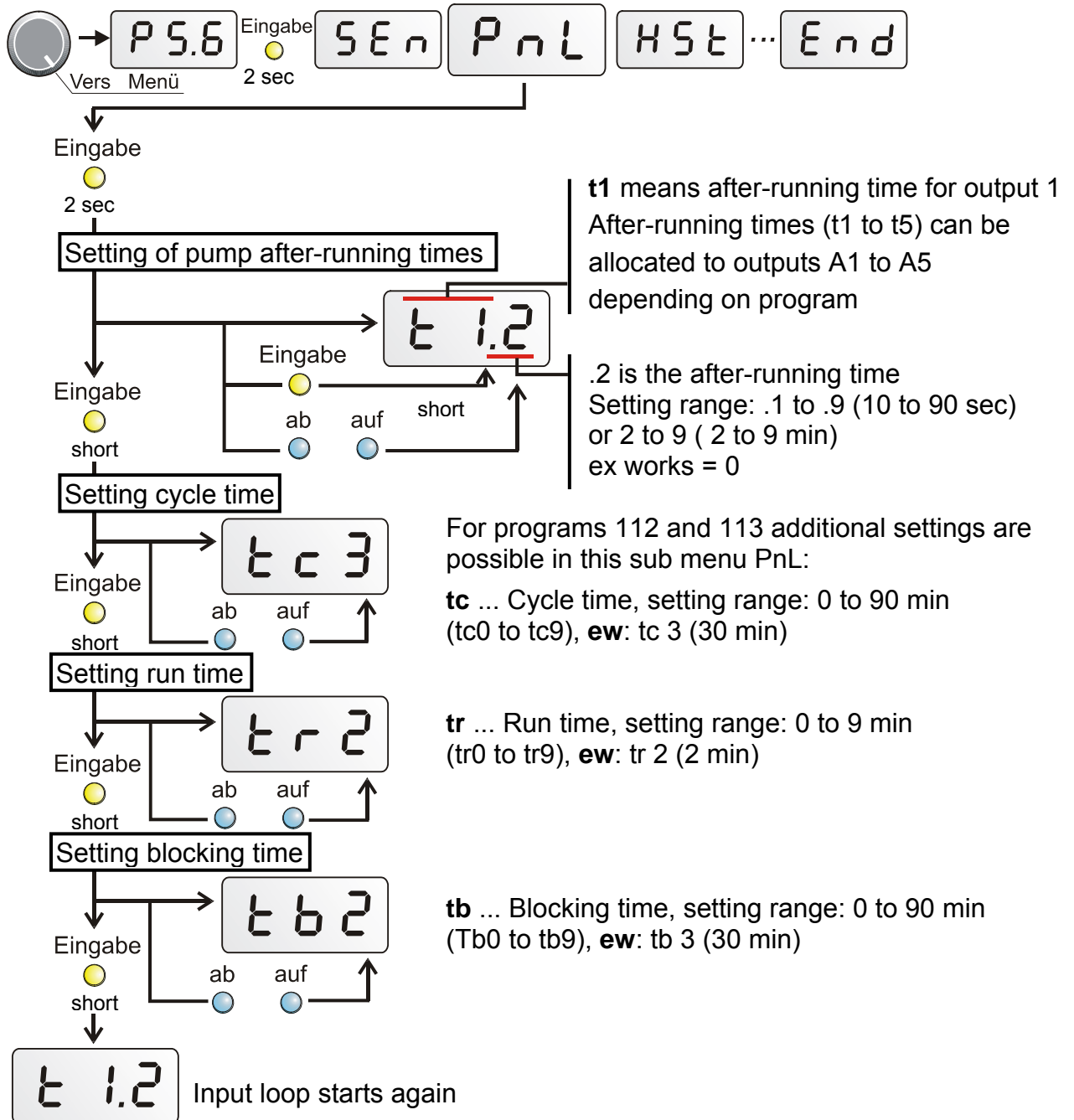

Exit from menu happens by pressing the yellow „**Eingabe**“ key for 2 seconds, turning the selector switch or automatically after one minute.

Switching hysteresees HSt HSt

Switching hysteresis is the difference between switch-on and switch-off temperature. I.e. a thermostat set to 70°C with 10K hysteresis switches off at 70°C and on at 60°C.

Hysteresees are not constant, but change with measured temperature. Setting range is between 1 to 9K per 64°C.

The changing according to temperature has the advantage, that different consumers resp. tanks can be used with the same settings at same time. Thus a pool with maximum temperature 30°C gets a lower hysteresis, a buffer tank with max. temperature 90°C a high one.

Each setting value of the selector switch (e.g. min1, min2, max etc.) has its own hysteresis.

The hysteresis of the differential values diff1, diff2 refer to the colder sensor. E.g. if the colder sensor shows 64°C, the output is switched on increasing the difference diff + hysteresis 3K and switched off decreasing the difference value diff.

H1	diff 1	H5	max
H2	diff 2	H6	frost protection limit
H3	min 1	H7	reserve
H4	min 2		

Example: H13 means hysteresis of diff1 with 3K per 64°C.
All hysteresees are set to 3K per 64°C ex works.

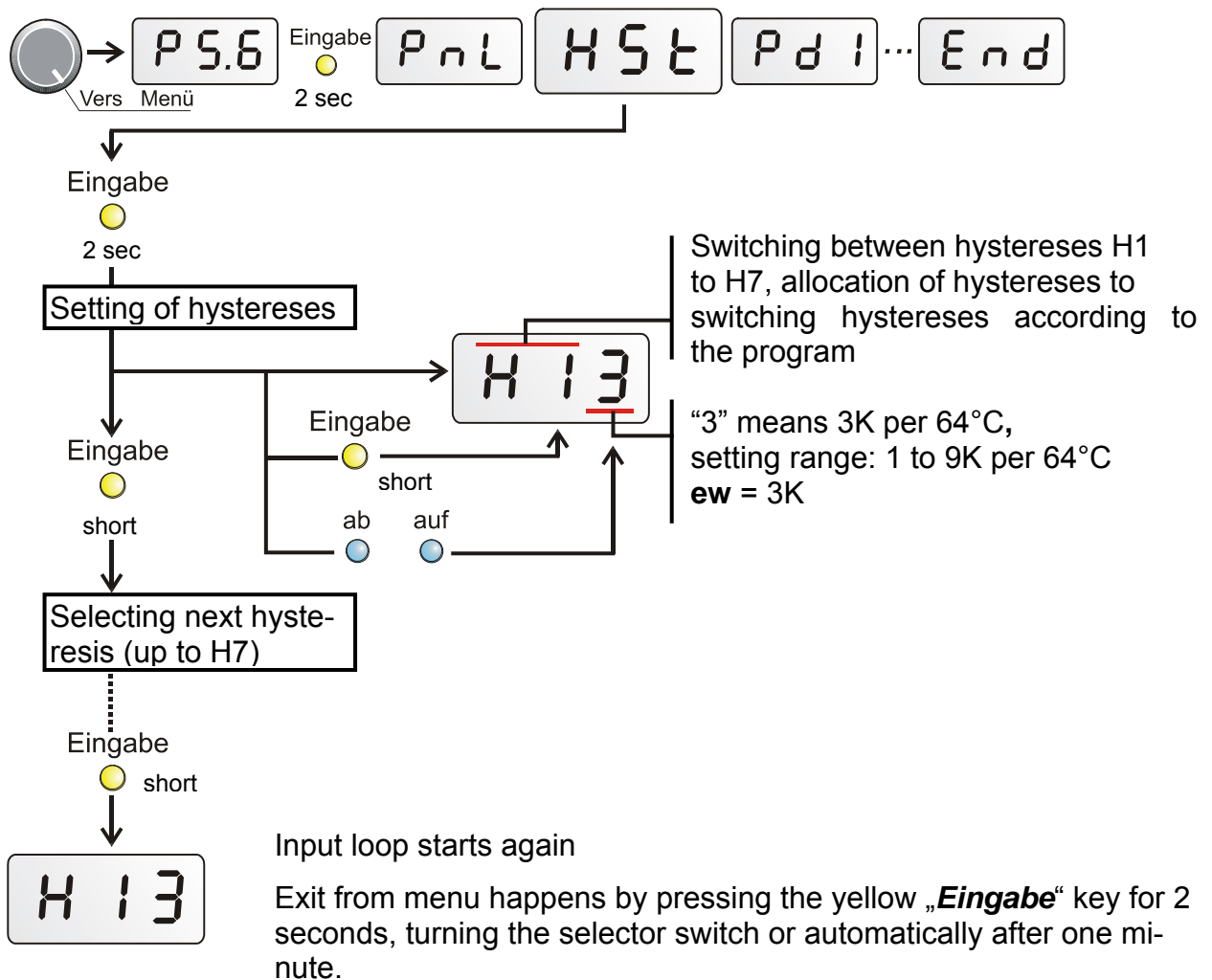

Pump speed control Pd1, Pd2

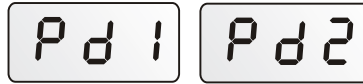

This menu allows activating and adjustment the outputs A1 and A2 for pump speed control.

Decrease of flow, e.g. in a boiler, causes – because of the longer dwell time in it – an increase of output temperature. So it is possible to get the boiler and the tank as well to a useable temperature level in short time, but that causes a worse efficiency.

The sensor creates together with controller, pump and the hydraulic system a control loop, which makes it possible to keep the temperature at the sensor constant by speed variation. Three control functions are available; they can be activated together:

- ◆ **Absolute value control** – Maintaining a sensor at constant temperature
- ◆ **Differential control** - Keeps the temperature constant between two sensors
- ◆ **Event control** - If a set temperature event occurs, the speed control starts, thus keeping a sensor constant.

Advice: Differential control and event control allow setting the temperature sensor T7. In this case T7 means nominal flow temperature Vsoll.

Setting of pump speed control for output A1

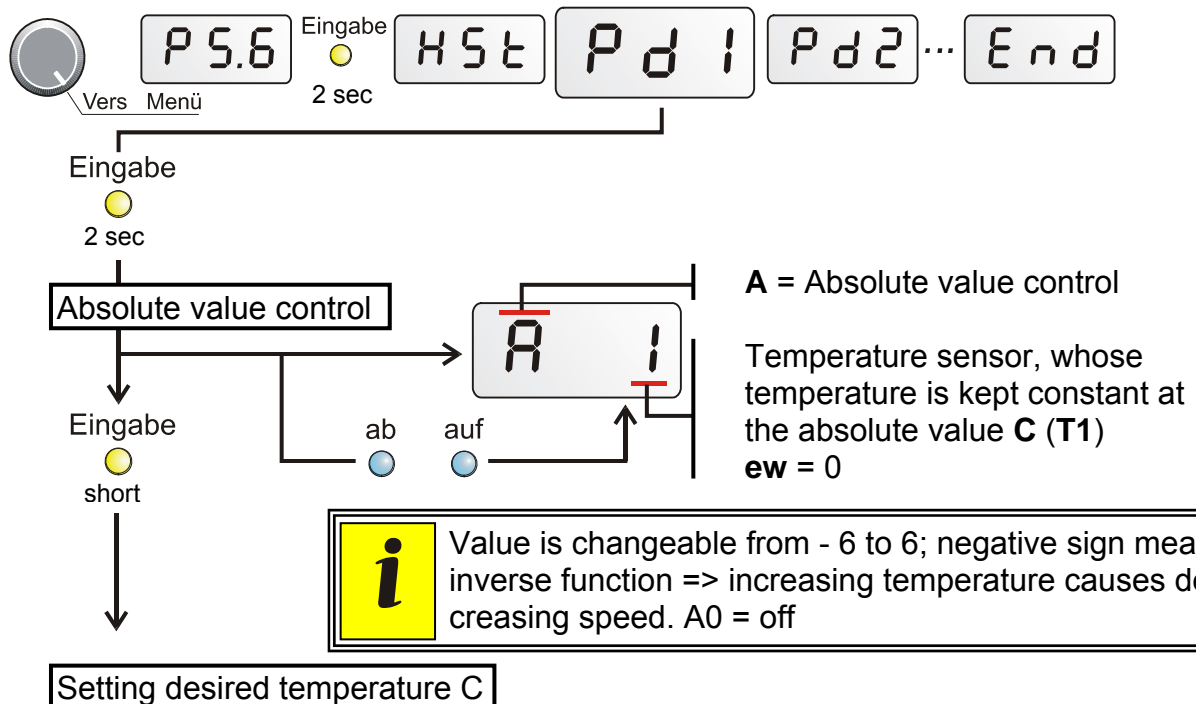

Setting desired temperature C

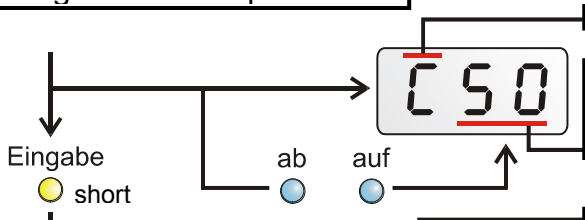

C = constant temperature value
 Temperature in °C,
 sensor is kept constant at this temperature
ew = 50°C

Differential control

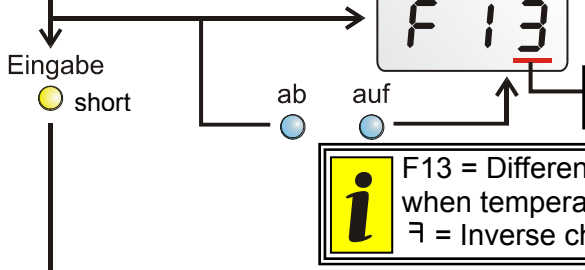

F = Differential control
 "1" = warmer temperature sensor **T1**
 "3" = colder temperature sensor **T3**
ew = 0

i F13 = Differential control between T1 and T3. Speed increases, when temperature difference increases
 ∇ = Inverse characteristic F 0 = Off

Setting differential temperature d

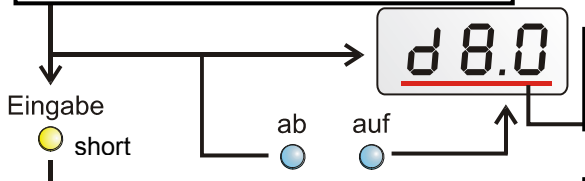

d8.0 = constant kept temperature difference
 8.0K between sensors **T1** and **T3** ("F13")
ew = 8.0K

Event control

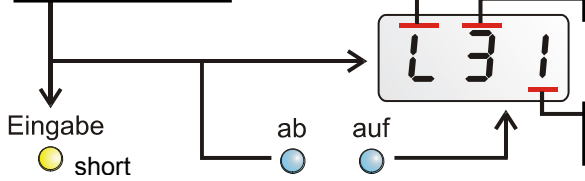

L = Event control (limiting function)
 On sensor **T3** operates value "b"
 On sensor **T1** operates value "H"
ew = 0

Limiting temperature b

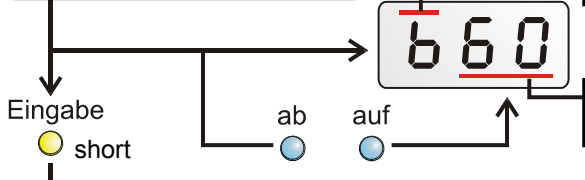

"b" = limiting temperature
 When sensor **T3** increases 60°C sensor **T1**
 will be kept at temperature "H", **ew** = 60°C

Maximum value H/h

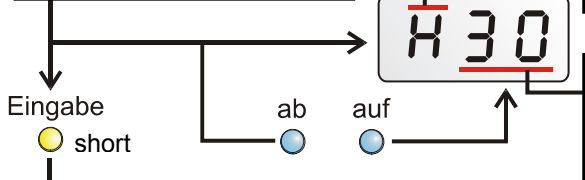

"h" = maximum value between 0 to 99°C
 "H" = maximum value between 100 to 199°C
H30 = Maximum value 130°C for the second
 set sensor in position "L" (Example: Sensor 1);
 sensor **T1** will be kept at 130°C constantly;
ew = H30 (130°C)

Setting proportional part

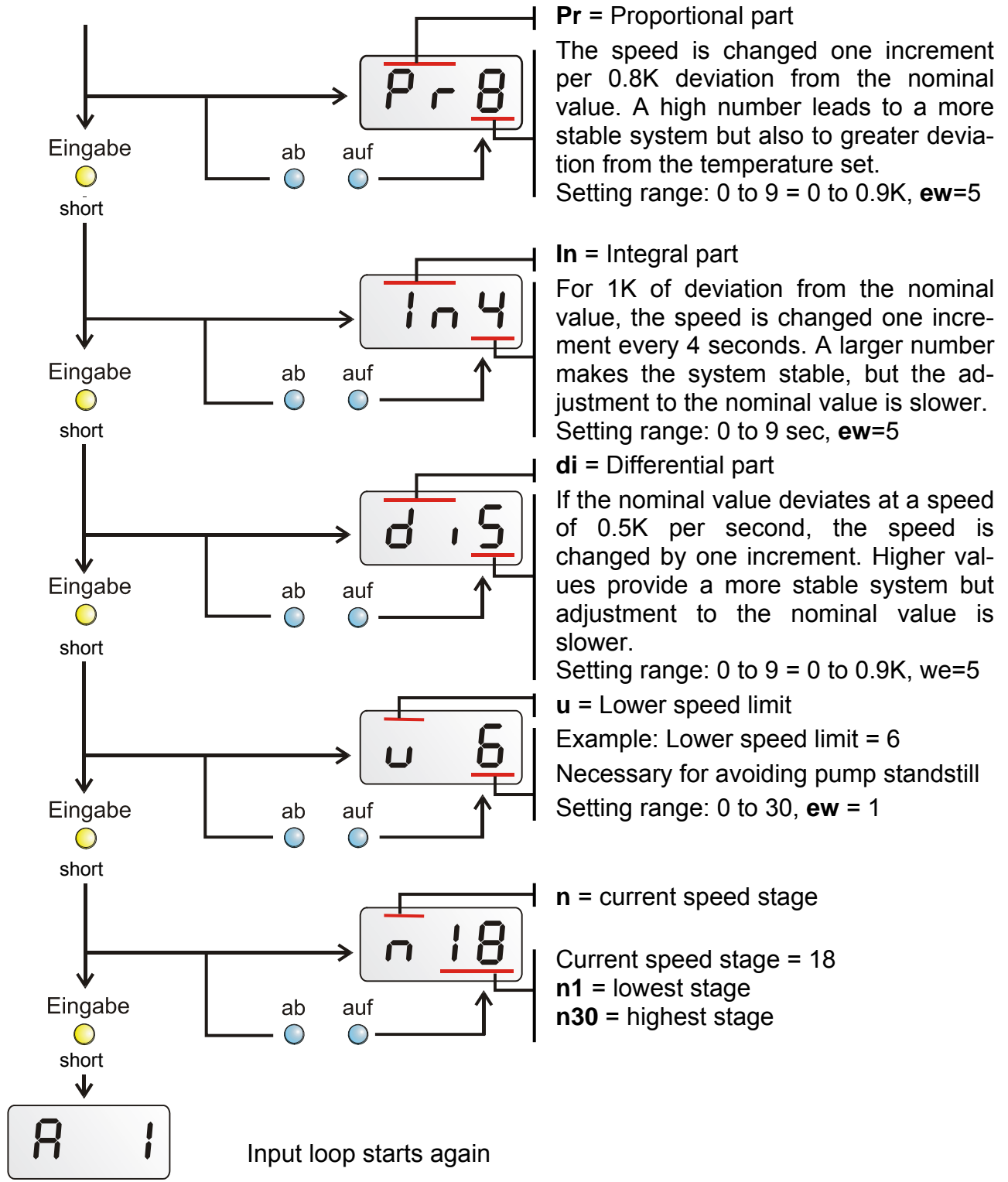

Exit from menu happens by pressing the yellow „Eingabe“ key for 2 seconds, turning the selector switch or automatically after one minute.

Technical Data

Power supply:	230V +-10%, 50- 60Hz,
Power input:	max. 4 VA
Fuse:	3.15 a fast acting (device & output)
Supply cable:	3x 1mm ² H05VV-F conforming to EN 60730-1
Protection class:	IP40
Allowed ambient temperature:	0 to 45°C
Sensors:	Pt1000, accuracy between 0 and 1000°C: +-0.35K
Tank sensor BFPT1000:	Diameter 6 mm, according to immersion sleeves, incl. 2 m cable (up to 90°C continuous load)
AUSPT:	Outdoor sensor in mounting housing (light grey)
RASPT:	Room sensor with possibility of remote control and switching between operating modes
Difference temperature:	adjustable from 0 to 99°C (diff)
Thresholds:	adjustable from 0 to 150°C (min, max)
Hysteresis:	adjustable from 1 to 9°C per 64°C
Speed control:	30 speed stages result in change of amount of max. 1:10.
Temperature display:	from -50 to +199°C
Resolution:	from -9.9 to 100°C with 0.1°C, otherwise 1°C
Accuracy:	typ. 0.4 and max. +-1K in range 0 to 100°C
Outputs:	Triac output 1 and output 2 (minimum load of 20W required) Relay contacts outputs 3, 4 and 5
Rated current load A1, A2:	250V / 1.5 A,
Rated current load A3, A4, A5:	250V / 2.5A
Quantity delivered:	Controller with 6 temperature sensors (3 x BFPT1000, 1 x KFPT1000, 1 x RASPT, 1 x AUSPT1000), 3 immersion sleeves 140mm, mounting material, mains cable with plug

Table of settings

If the control system fails unexpectedly, all of the settings should be reset for initial configuration. In this case, problems are inevitable if all of the setting values are entered in the following table. **If there are questions, this table has to be provided.** Only then is a simulation possible to reproduce the error.

ew = factory setting (ex works)

cs = controller settings

	ew	cs		ew	cs
Values					
Sensor T1		°C	Output A1	Aut	
Sensor T2		°C	Output A2	Aut	
Sensor T3		°C	Output A5	Aut	
Sensor T4		°C	Mixer output A3/A4	Aut	
Nom. flow value Vsoll		°C			
Sensor T5		°C	Program Prog.	0	
Sensor T6		°C	Version		

Basic, heat curve and mode parameters					
min1	60 °C	°C	Modus Mod	Aut	
min2	30 °C	°C	Par	rAS	
max	70 °C	°C			
diff1	5.0 K	K			
diff2	5.0 K	K			
Vmin	25 °C	°C			
Vmax	80 °C	°C			
T-20	70 °C	°C			
T+20	30 °C	°C			
Tnorm	20°C	°C			
Tab	15°C	°C			

Mixer control parameters <i>Mr</i>			Heating circuit pump parameter <i>HPu</i>		
Mixer control mode	Atr		Switch-off by room sensor	r - n	
Mixer run-time tL	3 min	min	Hysteresis room sensor rH	5	K
Averaging time of outdoor temperature n	5		Switch-off outdoor temperature	A - n	
Room influence r	50%	%	Nom. value outdoor temperature L	20°C	°C
Increase in switch-on power Eu	0 %	%	Averaging time of outdoor temperature n	5	
			Switch-off nominal flow temperature	S - J	
			Sensor for excess temperature protection function U	0	
			Temp. threshold C	90 °C	°C
			Mixer behavior	mS	

	ew	cs		ew	cs
Legionella protection function LES			Sensor type SEn		
Cycle time t_c	0	d	Sensor T1	F1P	
Start time h	17 h	h	Sensor T2	F2P	
Nominal temperature C	70 °C	°C	Sensor T3	F3P	
			Sensor T4	F4P	
			Sensor T5	F5P	
			Sensor T6	F6P	

Pump after-running time PnL			Hystereses HSt		
Output 1 t1	t10		Hysteresis H1	H13	
Output 2 t2	t20		Hysteresis H2	H23	
Output 5 t5	t50		Hysteresis H3	H33	
Cycle time t_c	tc3		Hysteresis H4	H43	
Run time tr	tr2		Hysteresis H5	H53	
Blocking time tb	tb3		Hysteresis H6	H63	

Speed control					
Speed control 1 Pd1			Speed control 2 Pd2		
Absolute value control	A 0		Absolute value control	A 0	
Desired value for A	c50	°C	Desired value for A	c50	°C
Differential control	F 0		Differential control	F 0	
Desired value for F	d8.0	K	Desired value for F	d8.0	K
Limiter function	L 0		Limiter function	L 0	
Limit for L	b60	°C	Limit for L	b60	°C
Maximum value for L	H30	°C	Maximum value for L	H30	°C
Proportional part	Pr5		Proportional part	Pr5	
Integral part	In5		Integral part	In5	
Differential part	di5		Differential part	di5	
Minimum speed	U 1		Minimum speed	U 1	

Time programs (Zeitprogr)										
	Program P1		Program P2		Program P3		Program P4		Program P5	
ON	P1.1		P2.1		P3.1		P4.1		P5.1	
OFF	P1.2		P2.2		P3.2		P4.2		P5.2	
ON	P1.3		P2.3		P3.3		P4.3		P5.3	
OFF	P1.4		P2.4		P3.4		P4.4		P5.4	
ON	P1.5		P2.5		P3.5		P4.5		P5.5	
OFF	P1.6		P2.6		P3.6		P4.6		P5.6	

Allocation of time programs to outputs and weekdays Tag ZP->A (enabled allocations of outputs are different depending to the program)			
Weekday	Output A1	Output A2	Output A5
Monday Mo			
Tuesday Di			
Wednesday Mi			
Thursday Do			
Friday Fr			
Saturday Sa			
Sunday So			

Instructions for troubleshooting

In general, all of the settings in the menus and the terminals should be checked if there is an error. The most frequent errors:

- ◆ Check the program number.
- ◆ If an output does not switch – check, if “**Auf**” is set at position “**Ausgang**”
- ◆ Check the thresholds for on/off (min/max) and the set differential temperatures (diff). Have the thermostat and differential thresholds been (resp. not been) reached?
- ◆ What is changed in the sub menus?
- ◆ Can the output be switched on/off in manual mode? - If endurance runs and standstill at the output produce an appropriate reaction, the unit is definitely not broken.
- ◆ Are all of the sensors connected to the right terminals? - Heat the sensor using a lighter and check the display.

Incorrect temperature displayed:

- ◆ If a value such as -999 is displayed when a sensor short-circuits or 999 if there is an interruption, the cause may not be a material or terminal error. Are the correct sensor types (KTY or PT1000) selected under the menu **SEn**? The factory settings have all inputs set to **P** (Pt1000).
- ◆ The sensor can also be checked without a measuring device simply by changing the part that is probably defective with one that works at the strip terminal and checking the display. The resistance measured with an ohmmeter should have the following value according to the temperature:

Temp. [°C]	0	10	20	25	30	40	50	60	70	80	90	100
R(Pt1000) [Ω]	1000	1039	1078	1097	1117	1155	1194	1232	1271	1309	1347	1385
R(KTY) [Ω]	1630	1772	1922	2000	2080	2245	2417	2597	2785	2980	3182	3392

If the unit does not run when it has power, the quick-blow fuse 3.15A that protects the control system and the output should be checked and exchanged if necessary.

The settings of the **menu functions ex works** can be **restored** at any time using the yellow key „**Eingabe**“ when plugging the unit in.

The settings of **all the parameters and menu functions ex works** can be restored at any time using both blue keys (“**ab/auf**”) when plugging the unit in.

As the programs are constantly being revised and improved, there may be a difference in the numbering of the sensors, pumps, and programs. Only the instruction manual provided with the device delivered applies (identical version number). The version number of the manual must correspond to the one for the device.

If the control system malfunctions despite these checks as described above, please contact your retailer or the manufacturer directly. The cause of the error can only be determined if the **table of settings has been completely filled** in along with a description of the error. If possible, also include a hydraulic diagram of the system.



TECHNISCHE ALTERNATIVE

ELEKTRONISCHE STEUERUNGSGERÄTEGESELLSCHAFT M. B. H.
A-3872 Amaliendorf, Langestraße 124

EC- DECLARATION OF CONFORMITY

Document- Nr.: / Date TA10009 / 02.09.2010
Company / Manufacturer: Technische Alternative
elektronische SteuerungsgerätegesmbH.
Address: A- 3872 Amaliendorf, Langestraße 124
Product: HZR 65
The stated above product complies with the following essential requirements:
EU requirements: 2006/95/EG Low voltage standard
2004/108/EG Electromagnetic compatibility

Employed standards:

EN 60730-1:2009 08 01 Automatic electrical controls for household and similar use -
Part 1: General requirements
EN 61000-6-3:2007 11 01 Electromagnetic compatibility (EMC) - Part 6-3: Generic
standards - Emission standard for residential, commercial
and light-industrial environments
EN 61000-6-2:2006 05 01 Electromagnetic compatibility (EMC) - Part 6-2: Generic
standards - Immunity for industrial environments
Position of CE - label: On packaging, manual and type label



Issuer: Technische Alternative
elektronische SteuerungsgerätegesmbH.
A- 3872 Amaliendorf, Langestraße 124

This declaration is submitted by:

General management

This declaration certifies the agreement with the named standards, contains however
no warranty of characteristics.
The security advices of included product documents are to be considered.

UIDNr.: ATU 17986204, Firmenbuch-Nr.: FN37578m, DVR-Nr.:1011553, ARA-Lizenz-Nr.:1996

Telefon ++43(0)2862/53635 Fax ++43(0)2862/53635-7 E-mail: mail@ta.co.at <http://www.ta.co.at>

Guarantee conditions

Note: The following guarantee conditions do not in any way limit the legal right to a guarantee, rather expand your rights as a consumer.

1. The company Technische Alternative elektronische Steuerungsgerätegesellschaft m. b. H. provides a two-year guarantee from the date of purchase by the end consumer for all the devices and parts which it sells. Defects must be reported immediately upon detection and within the guarantee period. Technical support knows the correct solution for nearly all problems. In this respect, contacting us immediately will help to avoid unnecessary expense or effort in troubleshooting.
2. The guarantee includes the free of charge repair (but not the cost of on site fault-finding, removal, refitting and shipping) of operational and material defects which impair operation. In the event that a repair is not, for reasons of cost, worthwhile according to the assessment of Technische Alternative, the goods will be replaced.
3. Not included is damage resulting from the effects of overvoltage or abnormal ambient conditions. Likewise, no guarantee liability can be accepted if the device defect is due to: transport damage for which we are not responsible, incorrect installation and assembly, incorrect use, non-observance of operating and installation instructions or incorrect maintenance.
4. The guarantee claim will expire if repairs or actions are carried out by persons who are not authorized to do so or have not been so authorized by us or if our devices are operated with spare, supplementary or accessory parts which are not considered to be original parts.
5. The defective parts must be sent to our factory with an enclosed copy of the proof of purchase and a precise description of the defect. A filled in "service advice note", which can be downloaded from our homepage www.ta.co.at, will accelerate processing. A prior clarification of the defect with our technical support is necessary.
6. Services provided under guarantee result neither in an extension of the guarantee period nor in a resetting of the guarantee period. The guarantee period for fitted parts ends with the guarantee period of the whole device.
7. Extended or other claims, especially those for compensation for damage other than to the device itself are, insofar as a liability is not legally required, excluded.

TECHNISCHE ALTERNATIVE

elektronische Steuerungsgerätegesellschaft m. b. H.

A-3872 Amaliendorf Langestraße 124

Tel ++43 (0)2862 53635

Fax ++43 (0)2862 53635 7

E-Mail: mail@ta.co.at

--- www.ta.co.at ---



© 2011