

UVR 64

Version P 5.3-2 EN

Four - Circuit Universal Controller



Operation

Installation instructions



TECHNISCHE
ALTERNATIVE

Informations

The hydraulic diagrams of this manual are only diagrams in principle. They do not describe or replace a professional system development. There is no guarantee for function if directly copied.

The settings of the **menu functions ex works** can be restored at any time using the yellow key ("Eingabe" = entry) when plugging the unit in.

The settings of **all the parameters and menu functions ex works** can be restored at any time using both blue keys ("ab/auf" = up/down) when plugging the unit in.

Table of contents

Safety requirements	5
Maintenance	5
Generally applicable rules	6
Hydraulic diagrams	7
Diagram 0: Solar power system with 2 consumers and 2 feed pumps	7
Diagram 16: Solar power system with 3 consumers and feed pump function	9
Diagram 32: Solar power system with 4 consumers	11
Diagram 48: Burner requirement, 2 feed pumps and simple solar power unit	13
Diagram 64: Solar power system with two solar panels and two consumers	18
Diagram 80: Layering storage tank, feed pump and domestic hot water preparation	21
Diagram 96: Solar power system with two consumers and two feed pump functions	24
Diagram A0: Solar system with two consumers, feed pump, burner requirement	26
Diagram B0: Solar power system, 2 feed pump functions, burner requirement	28
Diagram C0: Solar power system with 3 consumers, bypass function	30
Diagram D0: Simple solar power system, 2 feed pumps, feed pump for domestic hot water tank	32
Installing instructions	35
Installing the sensor(s)	35
Installing the unit	37
Electrical connection	37
Data line (DL)	38
Selector switch	39
Assignment of time windows (F>A)	41
Program selection (Progr.), Assignment of priority (Vorr.)	42
Additional functions	43
Programming procedure (Menü)	43
Sensor type	45
Function control	46
Collector excess temperature limit	47
Start function (ideal for tube collectors)	48
Priority menu	49
After-running time	50
Hysteresen	50
Pump speed control	51
Absolute value control A	51
Differential control F	52
Limiter function L	52
Waveform	52
Pump standstill	53
Stability problems	53
Pump speed processor	54
Auxiliary output A5	56
Instructions for troubleshooting	58
Table of settings	59
Technical data	61

Safety requirements:



All installation and wiring work on the controller must only be carried out in a zero-volts state.

The opening, connection and commissioning of the device may only be carried out by competent personnel. In so doing, all local security requirements must be adhered to.

The device corresponds to the latest state of the art and fulfills all necessary safety conditions. It may only be used or deployed in accordance with the technical data and the safety conditions and rules listed below. When using the device, the legal and safety regulations apposite to the particular use are also to be observed.

- ▶ The device must only be installed in a dry interior room.
- ▶ It must be possible to isolate the controller from the mains using an all-pole isolating device (plug/socket or double pole isolator).
- ▶ Before starting installation or wiring work, the controller must be completely isolated from the mains voltage and protected against being switched back on. Never interchange the safety extra-low voltage connections (sensor connections) with the 230V connections. Destructive and life-threatening voltages at the device and the connected sensors may occur.
- ▶ Solar thermal systems can become very hot. Consequently there is a risk of burns. Take care when fitting temperature sensors!
- ▶ For safety reasons, the system should only be left in manual mode when testing. In this operating mode, no maximum temperatures or sensor functions are monitored.
- ▶ Safe operation is no longer possible if the controller or connected equipment exhibits visual damage, no longer functions or has been stored for a lengthy period of time under unsuitable conditions. If this is the case, place the controller and equipment out of service and secure against unintentional use.

Maintenance:

The system does not require maintenance if handled and used properly. Use a cloth moistened with soft alcohol (such as spirit) to clean. Do not use cleansers and/or solvents such as trichlorethene.

As none of the components relevant to accuracy are under loads when used properly, they have a long service life without much drift. The unit thus does not have any adjustment options. No adjustments are needed.

The design characteristics of the unit must not be changed during repairs. Spare parts must correspond to the original spare parts and be as good as new.

Generally applicable rules for the proper use of this unit:

- ◆ When used for floor and wall heaters: here, a safety thermostat must be used just as with conventional heater controllers. It has to switch off the heating loop pump if there is overheating regardless of the output from the controller to prevent indirect damage from excess temperatures.
- ◆ It is necessary to set all „**Required settings**“ mentioned in the hydraulic diagrams.
- ◆ Relay output A4 can be made potential-free by resetting the jumpers.
- ◆ All programs +1 (+2, +4, +8)" indicates that the selected program number can be increased by the sum total of these numbers.

Example: Diagram 0, program 1 = pump-valve system

All programs +2: program also includes the boiler temperature T5

1+2 = 3 ⇒ pump-valve system including the boiler temperature T5

- ◆ **Linking of outputs:** Possibility to cancel out the numbered outputs listed in the program diagram against each other (e.g. A1 with A2, A1 with A3 or A2 with A3, etc.). By this means it is possible to assign the speed output at will. Addition of following numbers to the selected program number:

Linking of outputs	A1 with A3	+100	A1 with A4	+200
	A2 with A3	+300	A2 with A4	+400
	A1 with A3 & A2 with A4	+500	A3 with A4	+600

Program selection

The following hydraulic diagrams are basic functions. Changes resp. additional functions are described and defined by program numbers. The program number is the most important key to correct function of the control system. Only by input of this number the controller knows, which controlling business has to be done.

The program number is selected in the switch position **Prog** by the blue keys **ab/auf (=down/up)**.

Hydraulic diagrams

Diagram 0: Solar power system with 2 consumers and 2 feed pumps

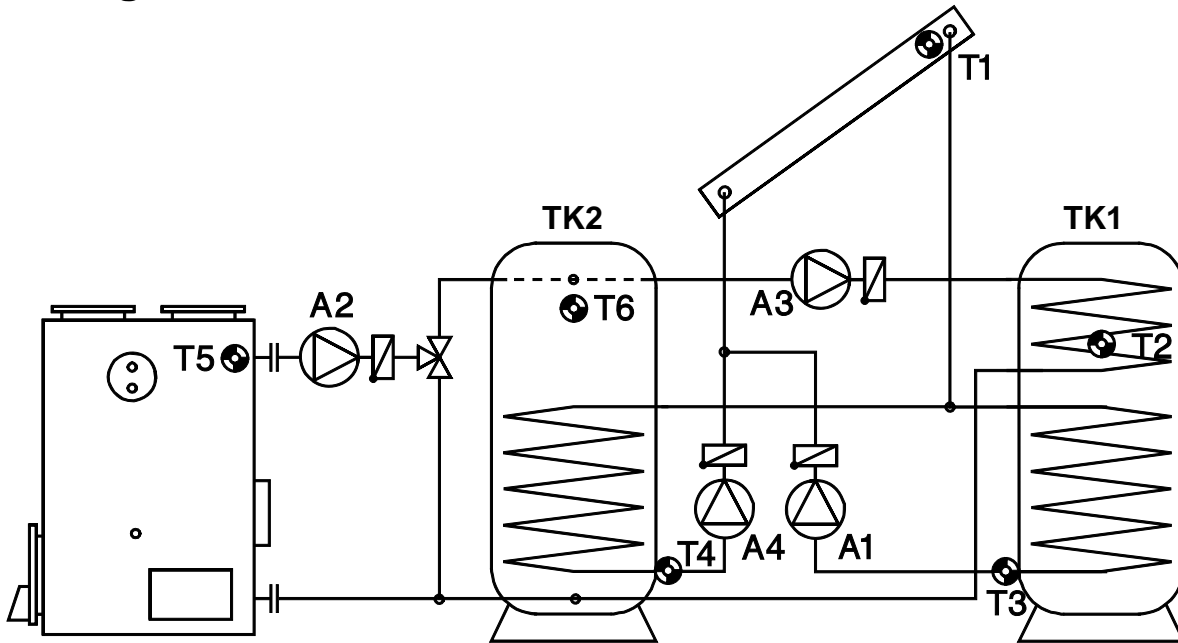

Sensors

- T1.... Collector
- T2.... Tank 1 top
- T3.... Tank 1 bottom
- T4.... Tank 2 bottom
- T5.... Boiler
- T6.... Tank 2 top

Outputs

- A1.... Solar pump circuit 1
- A2.... Feed pump tank 2
- A3.... Feed pump tank 1
- A4.... Solar pump circuit 2

Program 0: Function according to diagram

<div style="display: flex; justify-content: space-around;"> <div style="text-align: center;"> <p>T1</p> <p>↓ diff1 A1</p> <p>T3 max1</p> </div> <div style="text-align: center;"> <p>T5 min1</p> <p>↓ diff2 A2</p> <p>T4 max2 max4</p> </div> <div style="text-align: center;"> <p>T6 min2</p> <p>↓ diff3 A3</p> <p>T2 max3</p> </div> </div> <div style="margin-top: 20px; text-align: center;"> <p>↘ diff4 A4</p> </div>	<p>Required settings:</p> <table style="width: 100%; border: none;"> <tr> <td>diff1 ... coll. T1 – TK1 T3</td> <td style="text-align: right;">⇒ A1</td> </tr> <tr> <td>diff2 ... boiler T5 – TK2 T4</td> <td style="text-align: right;">⇒ A2</td> </tr> <tr> <td>diff3 ... TK2 T6 – TK1 T2</td> <td style="text-align: right;">⇒ A3</td> </tr> <tr> <td>diff4 ... coll. T1 – TK2 T4</td> <td style="text-align: right;">⇒ A4</td> </tr> <tr> <td>min1 ... switch-on temp. boiler T5</td> <td style="text-align: right;">⇒ A2</td> </tr> <tr> <td>min2 ... switch-on temp. TK2 T6</td> <td style="text-align: right;">⇒ A3</td> </tr> <tr> <td>max1 ... limit TK1 T3</td> <td style="text-align: right;">⇒ A1</td> </tr> <tr> <td>max2 ... limit TK 2 T4</td> <td style="text-align: right;">⇒ A2</td> </tr> <tr> <td>max3 ... limit TK 1 T2</td> <td style="text-align: right;">⇒ A3</td> </tr> <tr> <td>max4 ... limit TK 2 T4</td> <td style="text-align: right;">⇒ A4</td> </tr> </table> <p>Additional: Priority Vorr. (typical: A11, A20, A30, A42)</p>	diff1 ... coll. T1 – TK1 T3	⇒ A1	diff2 ... boiler T5 – TK2 T4	⇒ A2	diff3 ... TK2 T6 – TK1 T2	⇒ A3	diff4 ... coll. T1 – TK2 T4	⇒ A4	min1 ... switch-on temp. boiler T5	⇒ A2	min2 ... switch-on temp. TK2 T6	⇒ A3	max1 ... limit TK1 T3	⇒ A1	max2 ... limit TK 2 T4	⇒ A2	max3 ... limit TK 1 T2	⇒ A3	max4 ... limit TK 2 T4	⇒ A4
diff1 ... coll. T1 – TK1 T3	⇒ A1																				
diff2 ... boiler T5 – TK2 T4	⇒ A2																				
diff3 ... TK2 T6 – TK1 T2	⇒ A3																				
diff4 ... coll. T1 – TK2 T4	⇒ A4																				
min1 ... switch-on temp. boiler T5	⇒ A2																				
min2 ... switch-on temp. TK2 T6	⇒ A3																				
max1 ... limit TK1 T3	⇒ A1																				
max2 ... limit TK 2 T4	⇒ A2																				
max3 ... limit TK 1 T2	⇒ A3																				
max4 ... limit TK 2 T4	⇒ A4																				

$$\begin{aligned}
 A1 &= T1 > (T3 + \text{diff1}) \ \& \ T3 < \text{max1} \\
 A2 &= T5 > (T4 + \text{diff2}) \ \& \ T5 > \text{min1} \ \& \ T4 < \text{max2} \\
 A3 &= T6 > (T2 + \text{diff3}) \ \& \ T6 > \text{min2} \ \& \ T2 < \text{max3} \\
 A4 &= T1 > (T4 + \text{diff4}) \ \& \ T4 < \text{max4}
 \end{aligned}$$

Diagram 0

Program 1: Instead of the two solar pumps, one pump and a three-way valve are used (pump-valve system). The speed control (if activated) only operated when filling tank 1. Without a priority allocation, tank 2 is filled by priority.

A1... common pump

A4... Valve (A4/S receives power when filling tank)

All programs +2: In program 0 the feed of tank **TK1** by pump **A3** is only controlled by difference **TK2 T6 – TK1 T2**. This program also includes the boiler temperature. When feeding tank **TK1** by pump **A3** the difference boiler **T5 – TK1 T2** will be considered additionally (same setting **diff3**). Both **min** thresholds are active.

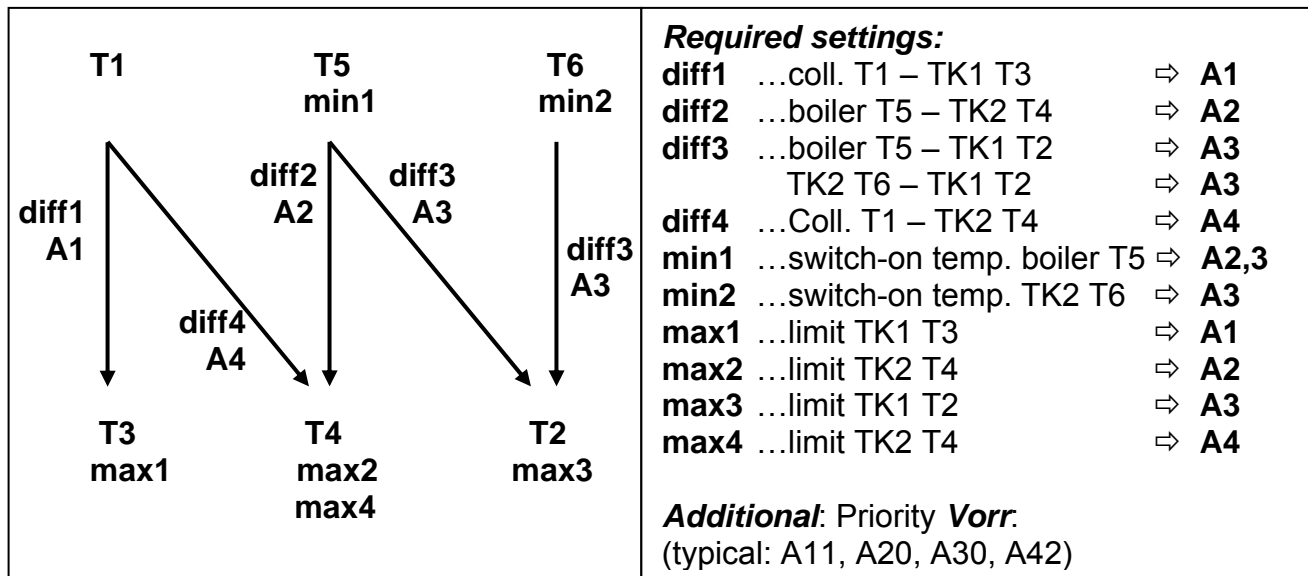

$$A1 = T1 > (T3 + diff1) \ \& \ T3 < max1$$

$$A2 = T5 > (T4 + diff2) \ \& \ T4 < max2 \ \& \ T5 > min1$$

$$A3 = T6 > (T2 + diff3) \ \& \ T2 < max3 \ \& \ T6 > min2$$

or
$$T5 > (T2 + diff3) \ \& \ T2 < max3 \ \& \ T5 > min1$$

$$A4 = T1 > (T4 + diff4) \ \& \ T4 < max4$$

All programs +4: If both tanks have reached their maximum temperature due to the solar power system, solar pump **A1** and feed pump **A3** are switched on (**reverse cooling function**). **A3 ... or** $T3 > max1 \ \& \ T6 < T3$

All programs +8: If both tanks have reached their maximum temperature due to the solar power system, solar pump **A4** and feed pump **A2** are switched on (**reverse cooling function**). **A2 ... or** $T4 > max2 \ \& \ T5 < T4$

Note: If a solar pump is switched off manually, the controller works during **reverse cooling** as the tank limit would be reached.

Program 12: The output **A2** becomes available, if the feed function of tank **TK2** is done by the boiler controller. In this program **A2** only switches with the thermostat function **max2** at **T5** (e.g. burner requirement)

Program 13: Function like program 12, but with pump–valve system at the solar sector (see program 1)

Program 14: Similar to Program 12. The burner requirement **A2** switches on at **min1** on **T5**. Switch off appears when **T2** has exceeded the threshold **max2**.

Program 15: Function like Program 14, but with pump–valve system in the solar system.

Diagram 16: Solar power system with 3 consumers and feed pump function.

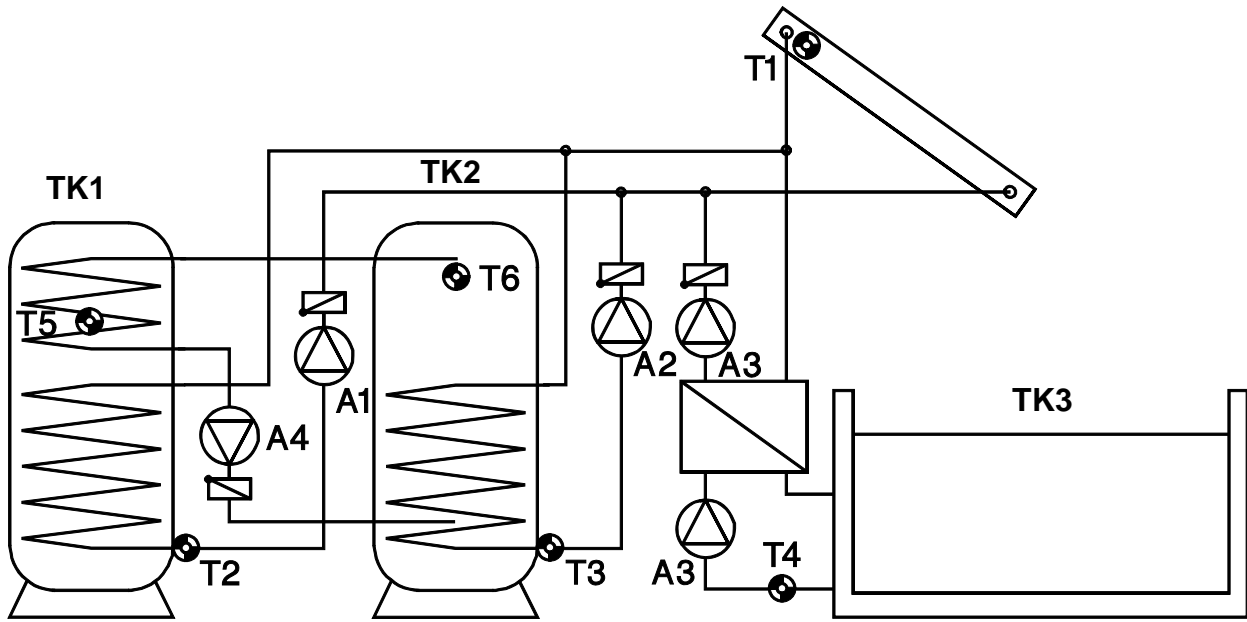

Sensors

- T1.... Collector
- T2.... Tank 1 bottom
- T3.... Tank 2 bottom
- T4.... Tank 3 (pool)
- T5.... Tank 1 top
- T6.... Tank 2 bottom

Outputs

- A1.... Solar pump tank TK1
- A2.... Solar pump buffer TK2
- A3.... Solar pump pool TK3
- A4.... Feed pump

Program 16: Function according to diagram

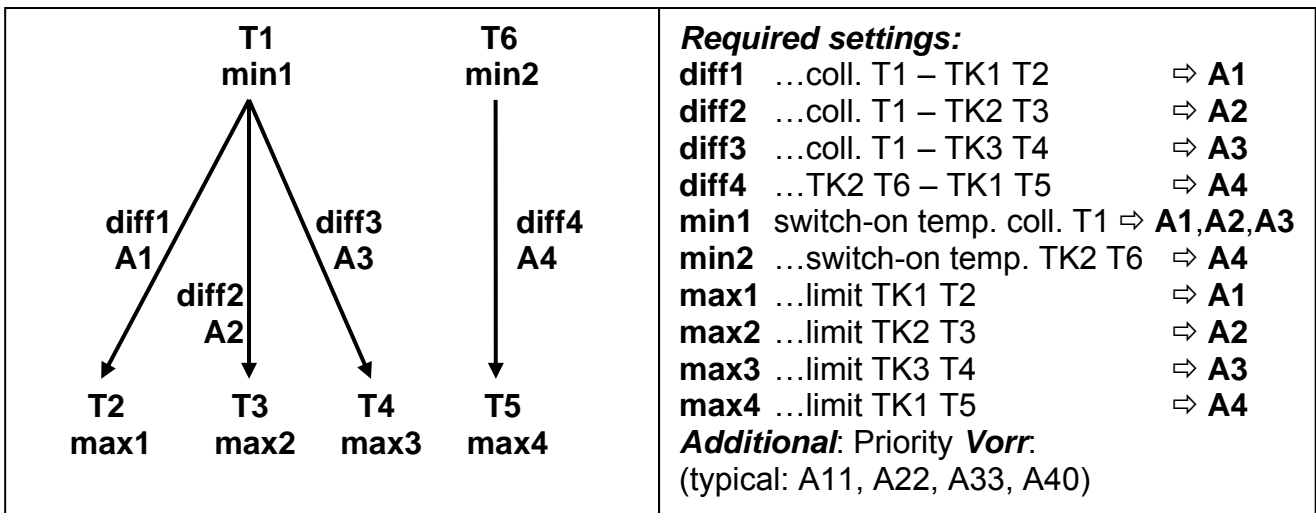

$$\begin{aligned}
 A1 &= T1 > (T2 + \text{diff1}) \ \& \ T1 > \text{min1} \ \& \ T2 < \text{max1} \\
 A2 &= T1 > (T3 + \text{diff2}) \ \& \ T1 > \text{min1} \ \& \ T3 < \text{max2} \\
 A3 &= T1 > (T4 + \text{diff3}) \ \& \ T1 > \text{min1} \ \& \ T4 < \text{max3} \\
 A4 &= T6 > (T5 + \text{diff4}) \ \& \ T6 > \text{min2} \ \& \ T5 < \text{max4}
 \end{aligned}$$

Diagram 16

Program 17: Pump-valve system between **TK1** und **TK2**. **TK1** and **TK2** are fed by a common pump **A1** and a three-way valve **A2**. The speed control (if activated) only operated when filling tank 1.

A1... common pump

A2... valve (A2/S receives power when filling tank **TK2**)

Program 18: Pump-valve system between **TK1** und **TK3**.

A1... common pump

A3... valve (A3/S receives power when filling tank **TK3**)

Program 19: A common pump feeds all **three** tanks. Valve **A3** switches between **TK2** and **TK3** and – in series – valve **A2** between **TK1** and **TK2**. I.e. if both valves are free from tension, **TK1** will be fed. The speed control (if activated) only operated when filling tank 1.

A1... common pump

A2... valve (A2/S receives power when filling tank **TK2**)

A3... valve (A3/S receives power when filling tank **TK3**)

If there is an active priority allocation, the two valves **A2** and **A3** are never switched on simultaneously: when filling into tank 2, only pump **A1** and valve **A2** are switched on, when filling into tank 3, only pump **A1** and valve **A3** are switched on.

All programs +4: **A4** is only a signal contact which shows, that all tanks have reached their *max*-thresholds.

All programs +8: If all tanks have reached their maximum temperature due to the solar power system, tank **TK2** will be fed regardless of *max2*.

Diagram 32: Solar power system with 4 consumers

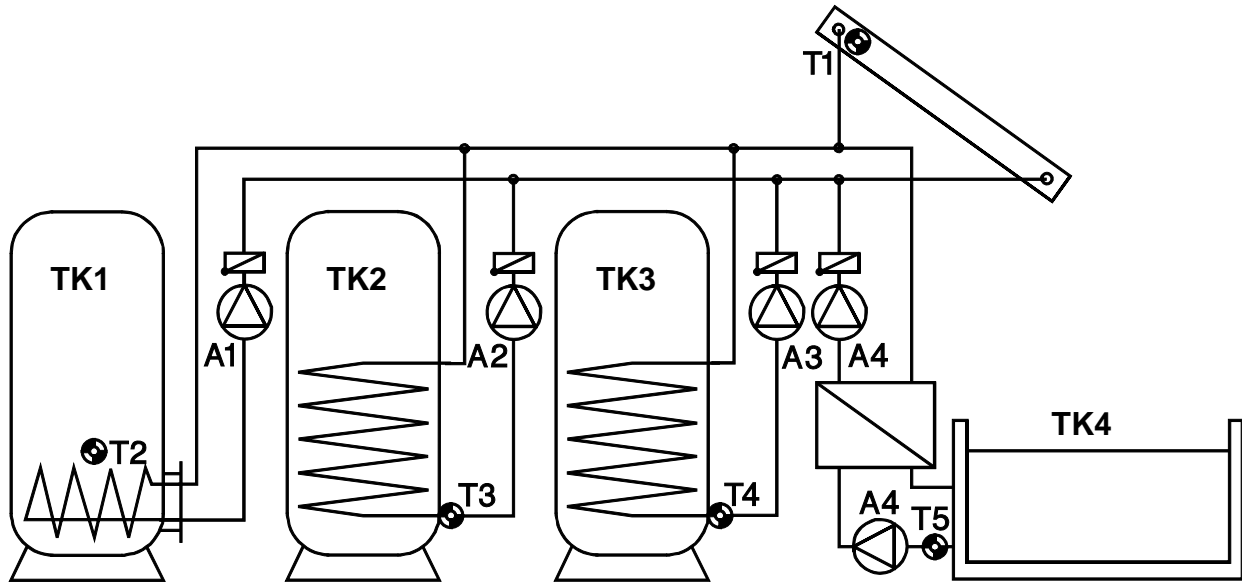

Sensors

- T1.... Collector
- T2.... Tank 1 (TK1)
- T3.... Tank 2 (TK2)
- T4.... Tank 3 (TK3)
- T5.... Tank 4 (pool TK4)
- T6.... Freely usable

Outputs

- A1.... Solar pump TK1
- A2.... Solar pump buffer TK2
- A3.... Solar pump buffer TK3
- A4.... Solar pump pool TK4

Program 32: Function according to diagram

	<p>Required settings:</p> <table style="width: 100%; border: none;"> <tr> <td>diff1 ...coll. T1 – TK1 T2</td> <td style="text-align: right;">⇒ A1</td> </tr> <tr> <td>diff2 ...coll. T1 – TK 2 T3</td> <td style="text-align: right;">⇒ A2</td> </tr> <tr> <td>diff3 ...coll. T1 – TK 3 T4</td> <td style="text-align: right;">⇒ A3</td> </tr> <tr> <td>diff4 ...coll. T1 – TK 4 T5</td> <td style="text-align: right;">⇒ A4</td> </tr> <tr> <td>min1 ...switch-on temp. coll. T1</td> <td style="text-align: right;">⇒ A1, A2, A3, A4</td> </tr> <tr> <td>max1 ...limit TK 1 T2</td> <td style="text-align: right;">⇒ A1</td> </tr> <tr> <td>max2 ...limit TK 2 T3</td> <td style="text-align: right;">⇒ A2</td> </tr> <tr> <td>max3 ...limit TK 3 T4</td> <td style="text-align: right;">⇒ A3</td> </tr> <tr> <td>max4 ...limit TK 4 T5</td> <td style="text-align: right;">⇒ A4</td> </tr> </table> <p>Additional: Priority <i>Vorr.</i> (typical: A11, A22, A33, A44)</p>	diff1 ...coll. T1 – TK1 T2	⇒ A1	diff2 ...coll. T1 – TK 2 T3	⇒ A2	diff3 ...coll. T1 – TK 3 T4	⇒ A3	diff4 ...coll. T1 – TK 4 T5	⇒ A4	min1 ...switch-on temp. coll. T1	⇒ A1, A2, A3, A4	max1 ...limit TK 1 T2	⇒ A1	max2 ...limit TK 2 T3	⇒ A2	max3 ...limit TK 3 T4	⇒ A3	max4 ...limit TK 4 T5	⇒ A4
diff1 ...coll. T1 – TK1 T2	⇒ A1																		
diff2 ...coll. T1 – TK 2 T3	⇒ A2																		
diff3 ...coll. T1 – TK 3 T4	⇒ A3																		
diff4 ...coll. T1 – TK 4 T5	⇒ A4																		
min1 ...switch-on temp. coll. T1	⇒ A1, A2, A3, A4																		
max1 ...limit TK 1 T2	⇒ A1																		
max2 ...limit TK 2 T3	⇒ A2																		
max3 ...limit TK 3 T4	⇒ A3																		
max4 ...limit TK 4 T5	⇒ A4																		

$$\begin{aligned}
 A1 &= T1 > (T2 + \text{diff1}) \ \& \ T1 > \text{min1} \ \& \ T2 < \text{max1} \\
 A2 &= T1 > (T3 + \text{diff2}) \ \& \ T1 > \text{min1} \ \& \ T3 < \text{max2} \\
 A3 &= T1 > (T4 + \text{diff3}) \ \& \ T1 > \text{min1} \ \& \ T4 < \text{max3} \\
 A4 &= T1 > (T5 + \text{diff4}) \ \& \ T1 > \text{min1} \ \& \ T5 < \text{max4}
 \end{aligned}$$

Diagram 32

Program 33: Pump-valve system between **TK1** und **TK2**. **TK1** and **TK2** are fed by a common pump **A1** and a three-way valve **A2**. The speed control (if activated) only operated when filling tank 1.

A1... common pump

A2... valve (A2/S receives power when filling tank **TK2**)

All programs +2: Pump-valve system between **TK1** und **TK3**.

A1... common pump

A3... valve (A3/S receives power when filling tank **TK3**)

All programs +4: Pump-valve system between **TK1** und **TK4**.

A1... common pump

A4... valve (A4/S receives power when filling tank **TK4**)

All programs +8: If all tanks have reached their maximum temperature due to the solar power system, tank **TK2** will be fed regardless of *max2*.

Diagram 48: Burner requirement, 2 feed pumps and simple solar power unit

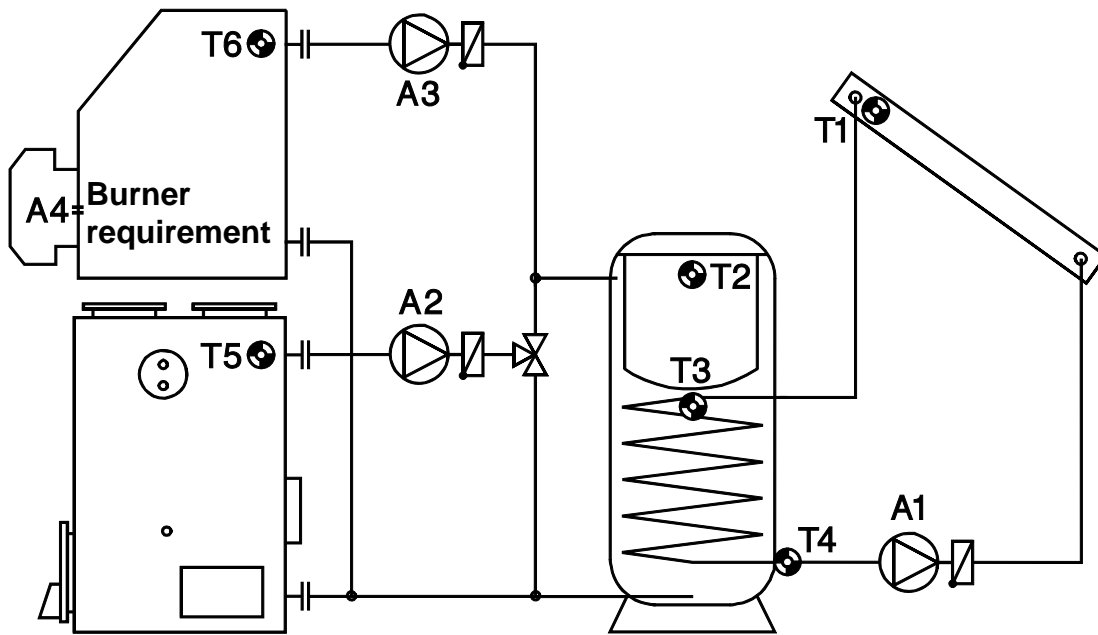

Sensors

- T1.... Collector
- T2.... Tank top
- T3.... Tank center
- T4.... Tank bottom
- T5.... Solid fuel boiler ("sfb")
- T6.... Oil/gas boiler ("ogb")

Outputs

- A1.... Solar pump
- A2.... Feed pump solid fuel boiler
- A3.... Feed pump oil/gas boiler
- A4.... Burner requirement

Program 48: Function according to diagram

T1	T5 min1	T6 min2	Burner A4 T2 max4	<p>Required settings:</p> <p>diff1 ...coll. T1 – TK T4 ⇨ A1</p> <p>diff2 ...sf-boiler T5 – TK T4 ⇨ A2</p> <p>diff3 ...oil boiler T6 – TK T3 ⇨ A3</p> <p>diff4 ...see all programs +8</p> <p>min1 ...switch-on temp. sfb T5 ⇨ A2</p> <p>min2 ...switch-on temp. ogb T6 ⇨ A3</p> <p>max1 ...limit TK T4 ⇨ A1</p> <p>max2 ...limit TK T4 ⇨ A2</p> <p>max3 ...limit TK T3 ⇨ A3</p> <p>max4 ...burner requirement TK T2 ⇨ A4</p>
↓ diff1 A1 ↓ T4 max1 max2	↘ diff2 A2 ↓ T3 max3	↓ diff3 A3 ↓ T3 max3		

$$\begin{aligned}
 A1 &= T1 > (T4 + \text{diff1}) \ \& \ T4 < \text{max1} \\
 A2 &= T5 > (T4 + \text{diff2}) \ \& \ T5 > \text{min1} \ \& \ T4 < \text{max2} \\
 A3 &= T6 > (T3 + \text{diff3}) \ \& \ T6 > \text{min2} \ \& \ T3 < \text{max3} \\
 A4 \text{ (on)} &= T2 < \text{max4} - \text{hysteresis} \\
 A4 \text{ (off)} &= T2 > \text{max4}
 \end{aligned}$$

Diagram 48

Program 49: If the tank has reached its maximum temperature due to the solar power system, solar pump **A1** and feed pump **A2** are switched on (**reverse cooling function**).

A2 ... or $T4 > max1$ & $T5 < T4$

All Programs +2: Output **A4** (burner requirement) switches on when **T2** falls below threshold **max4** and switches off when **T3** exceeds **max3**. **Max3** is no longer the tank limit for the oil/gas boiler feed pump.

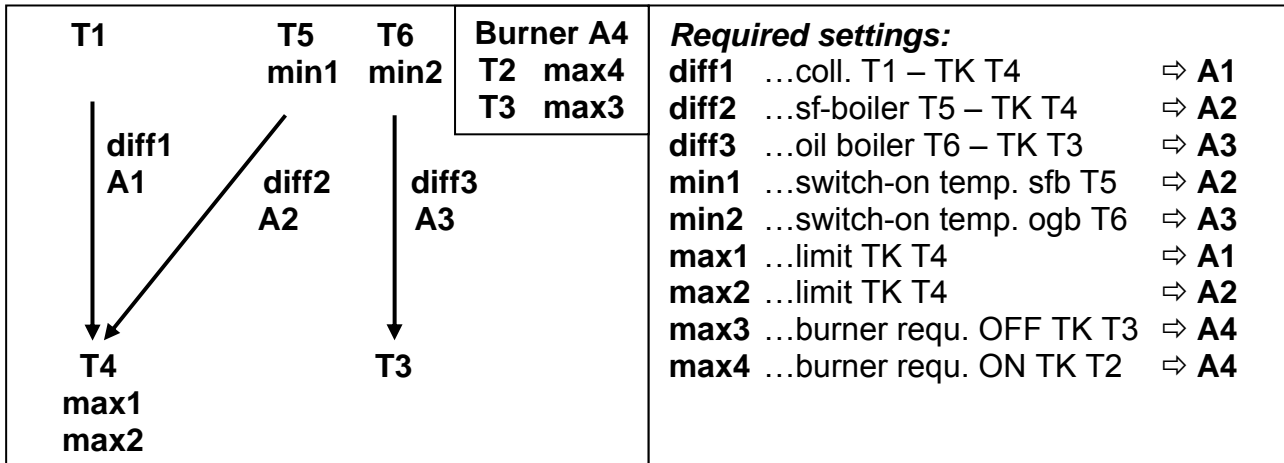

$$A1 = T1 > (T4 + diff1) \ \& \ T4 < max1$$

$$A2 = T5 > (T4 + diff2) \ \& \ T5 > min1 \ \& \ T4 < max2$$

$$A3 = T6 > (T3 + diff3) \ \& \ T6 > min2$$

$$A4 \ (on) = T2 < max4 - hysteresis$$

$$A4 \ (off) = T3 > max3$$

All Programs +4: Three independent differential loops. The tank feeding **A2** from the solid fuel boiler is controlled by the difference **diff2** between boiler sensor **T5** and the sensor **T2** (tank top)

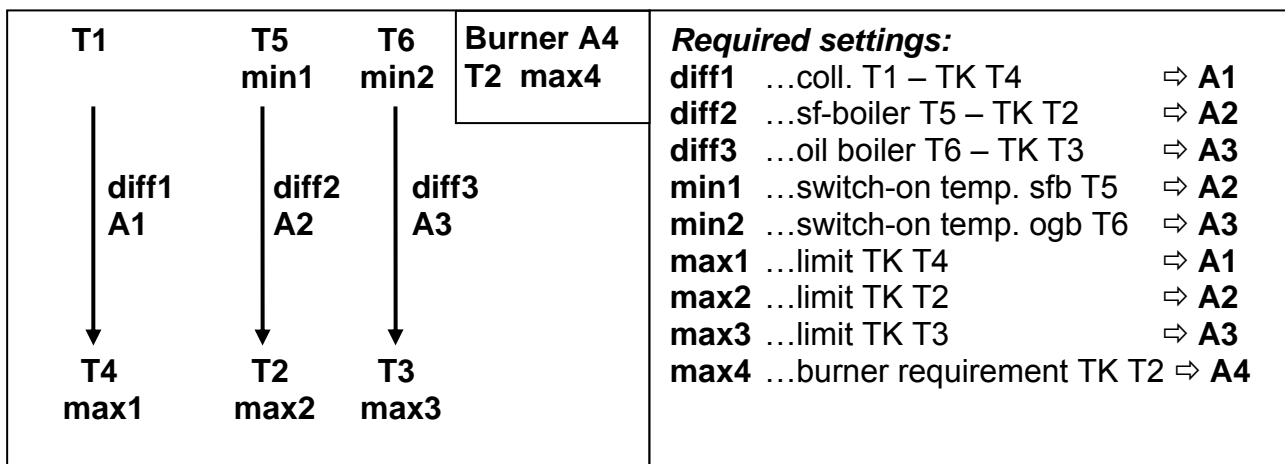

$$A1 = T1 > (T4 + diff1) \ \& \ T4 < max1$$

$$A2 = T5 > (T2 + diff2) \ \& \ T5 > min1 \ \& \ T2 < max2$$

$$A3 = T6 > (T3 + diff3) \ \& \ T6 > min2 \ \& \ T3 < max3$$

$$A4 \ (on) = T2 < max4 - hysteresis$$

$$A4 \ (off) = T2 > max4$$

All Programs +8: This program enables controlling of two generators to each one consumer. Output **A4** is switched with the difference **diff4** between **T2** and **T3** instead of burner requirement. **T2** is available for an additional fourth generator. In this case threshold **max4** operates at **T3**.

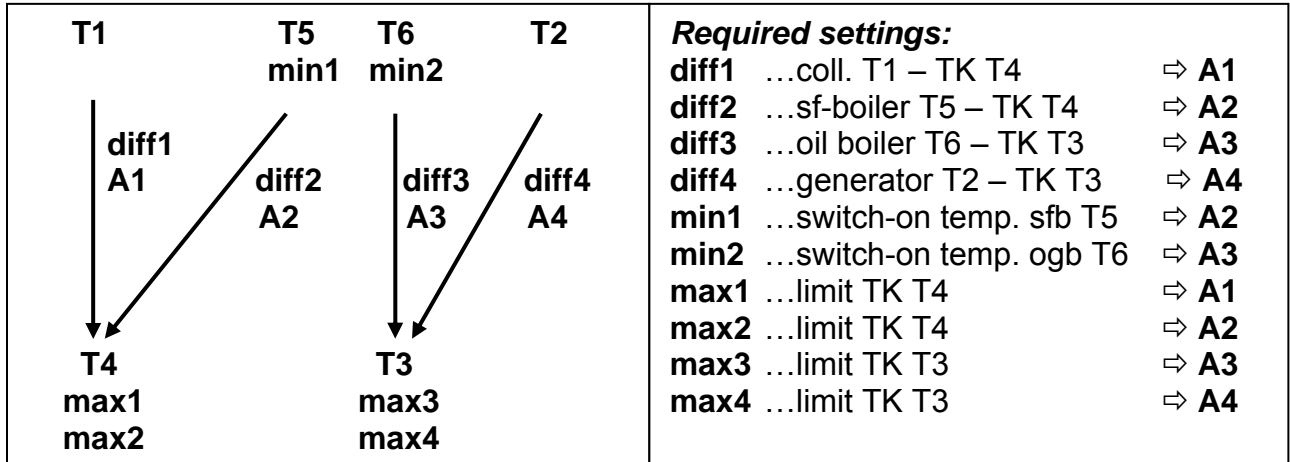

$$A1 = T1 > (T4 + diff1) \ \& \ T4 < max1$$

$$A2 = T5 > (T4 + diff2) \ \& \ T5 > min1 \ \& \ T4 < max2$$

$$A3 = T6 > (T3 + diff3) \ \& \ T6 > min2 \ \& \ T3 < max3$$

$$A4 = T2 > (T3 + diff4) \ \& \ T3 < max4$$

Program 60: The whole function offers switching of two generators to one consumer and one generator to two consumers. Output **A4** gets an additional difference function instead of burner requirement. **A4** switches, if sensor **T6** is increasing **min2** and is greater than **T2** by **diff4** and **T2** has not exceeded **max4**.

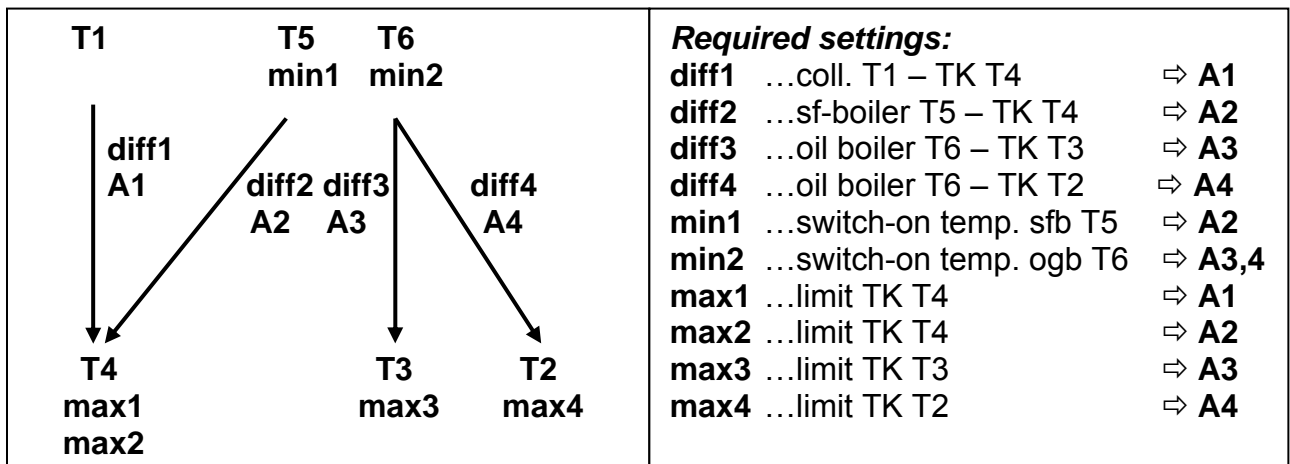

$$A1 = T1 > (T4 + diff1) \ \& \ T4 < max1$$

$$A2 = T5 > (T4 + diff2) \ \& \ T5 > min1 \ \& \ T4 < max2$$

$$A3 = T6 > (T3 + diff3) \ \& \ T6 > min2 \ \& \ T3 < max3$$

$$A4 = T6 > (T2 + diff4) \ \& \ T6 > min2 \ \& \ T2 < max4$$

Diagram 48

Program 61: Function similar to Program 60, but output **A3** does not only switch by the origin function, but additionally, if **T5** is increasing *min1* and is greater than **T3** by *diff3*

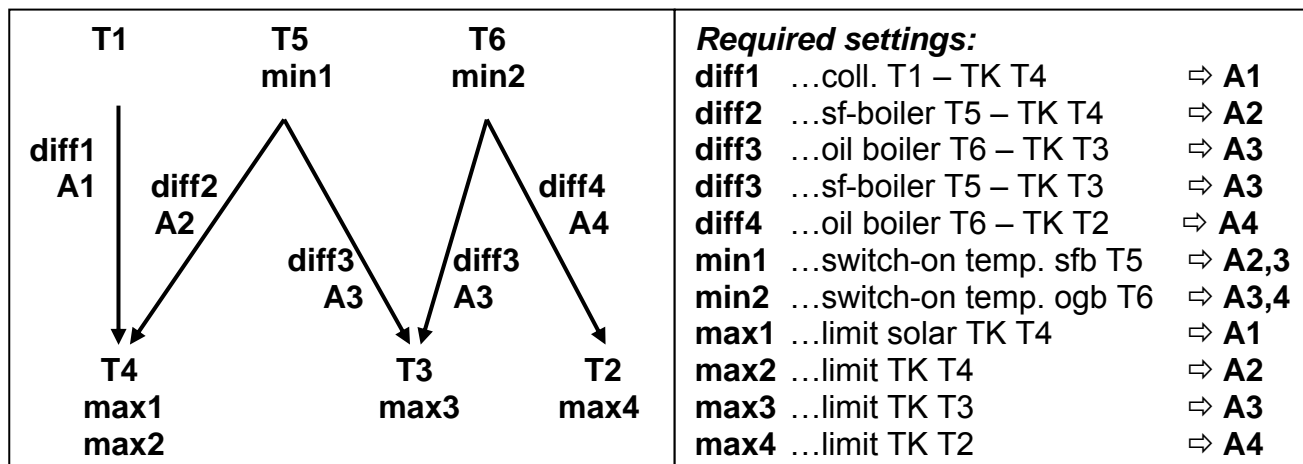

$$\begin{aligned}
 A1 &= T1 > (T4 + \text{diff1}) \ \& \ T4 < \text{max1} \\
 A2 &= T5 > (T4 + \text{diff2}) \ \& \ T5 > \text{min1} \ \& \ T4 < \text{max2} \\
 A3 &= T6 > (T3 + \text{diff3}) \ \& \ T6 > \text{min2} \ \& \ T3 < \text{max3} \\
 \text{or} \quad & T5 > (T3 + \text{diff3}) \ \& \ T5 > \text{min1} \ \& \ T3 < \text{max3} \\
 A4 &= T6 > (T2 + \text{diff4}) \ \& \ T6 > \text{min2} \ \& \ T2 < \text{max4}
 \end{aligned}$$

Program 62: Additionally to program 60 output **A4** switches, if **T5** is increasing *min1* and is greater than **T2** by *diff4*.

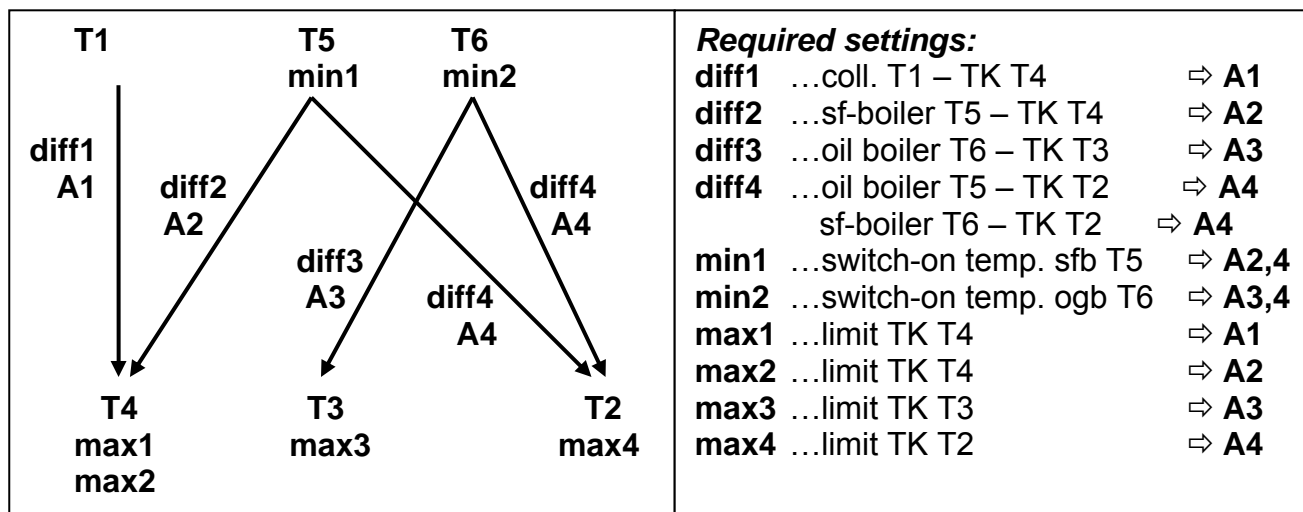

$$\begin{aligned}
 A1 &= T1 > (T4 + \text{diff1}) \ \& \ T4 < \text{max1} \\
 A2 &= T5 > (T4 + \text{diff2}) \ \& \ T5 > \text{min1} \ \& \ T4 < \text{max2} \\
 A3 &= T6 > (T3 + \text{diff3}) \ \& \ T6 > \text{min2} \ \& \ T3 < \text{max3} \\
 A4 &= T6 > (T2 + \text{diff4}) \ \& \ T6 > \text{min2} \ \& \ T2 < \text{max4} \\
 \text{or} \quad & T5 > (T2 + \text{diff4}) \ \& \ T5 > \text{min1} \ \& \ T2 < \text{max4}
 \end{aligned}$$

Program 63: Output **A3** switches as described in program 61 and **A4** as per program 62.

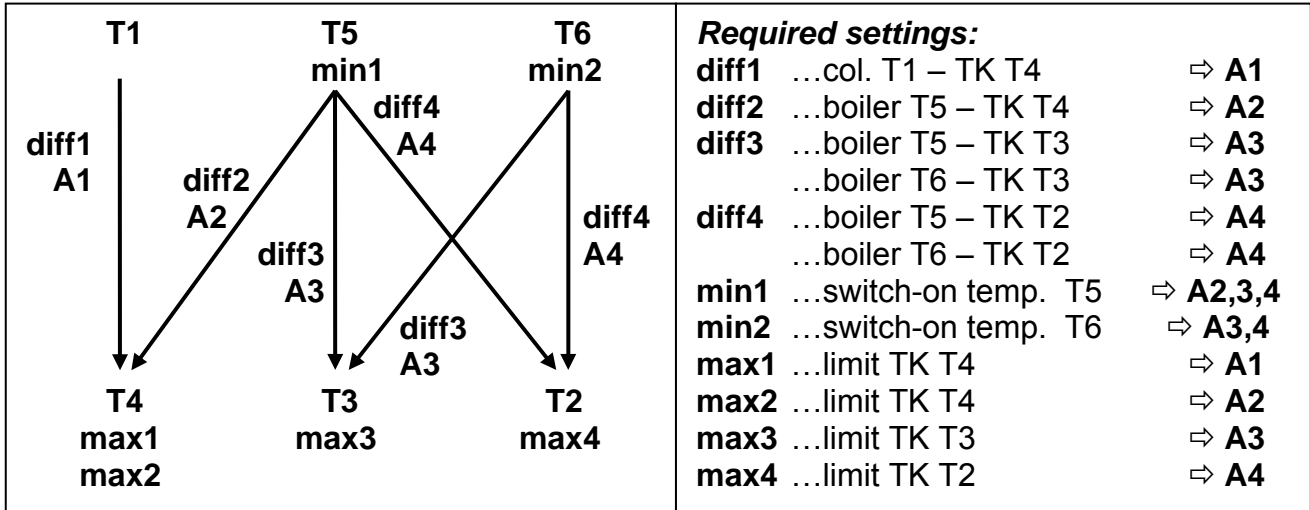

$$\begin{aligned}
 A1 &= T1 > (T4 + diff1) \ \& \ T4 < max1 \\
 A2 &= T5 > (T4 + diff2) \ \& \ T5 > min1 \ \& \ T4 < max2 \\
 A3 &= T5 > (T3 + diff3) \ \& \ T5 > min1 \ \& \ T3 < max3 \\
 \text{or} \quad & \quad \quad \quad T6 > (T3 + diff3) \ \& \ T6 > min2 \ \& \ T3 < max3 \\
 A4 &= T5 > (T2 + diff4) \ \& \ T5 > min1 \ \& \ T2 < max4 \\
 \text{or} \quad & \quad \quad \quad T6 > (T2 + diff4) \ \& \ T6 > min2 \ \& \ T2 < max4
 \end{aligned}$$

Diagram 64

Diagram 64: Solar power system with two solar panels and two consumers

Note: Setting the time switch, the definition of the output corresponds to the actual output, but setting the priority it corresponds to the basic function of program 64.

Program 64: Each tank is fed from each solar panel by 4 separate pumps. No feed pump function!

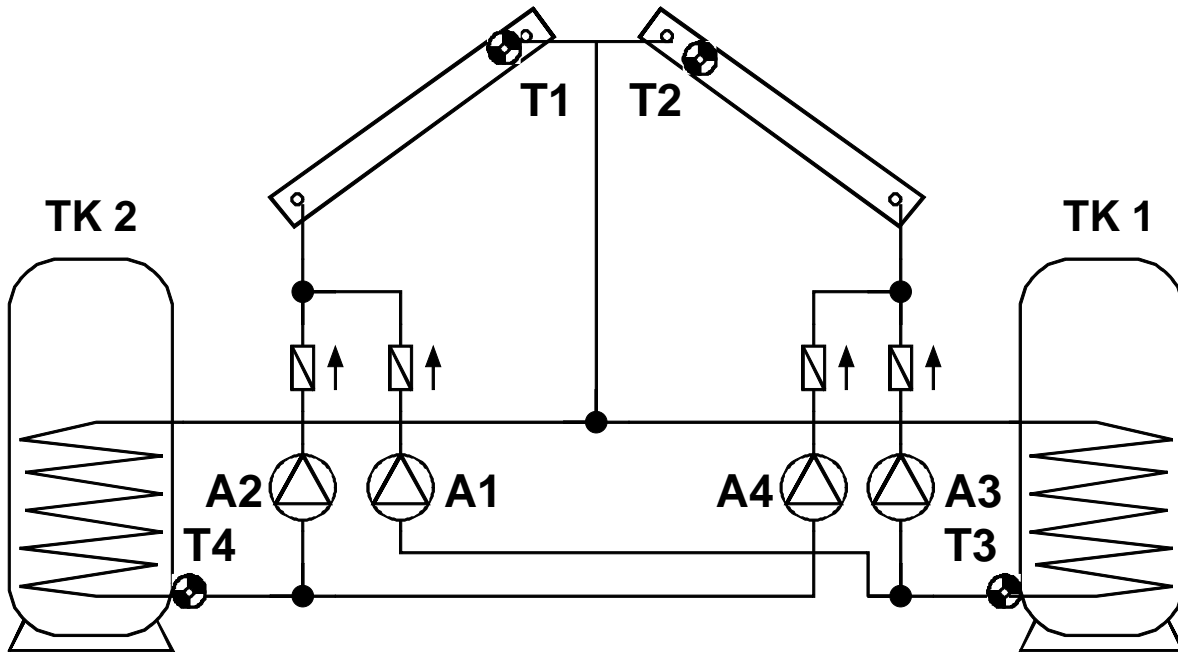

Sensor

- T1.... Collector 1
- T2.... Collector 2
- T3.... Tank 1 bottom
- T4.... Tank 2 bottom
- T5.... Freely usable
- T6.... Freely usable

Outputs

- A1.... Pump collector 1 – TK1
- A2.... Pump collector 1 – TK2
- A3.... Pump collector 2 – TK1
- A4.... Pump collector 2 – TK2

Program 64: Function according to diagram

	<p>Required settings:</p> <p>diff1 ...coll. T1 – TK1 T3 ⇨ A1 coll. T2 – TK1 T3 ⇨ A3</p> <p>diff2 ...coll. T1 – TK2 T4 ⇨ A2 coll. T2 – TK2 T4 ⇨ A4</p> <p>diff3 ...see all programs +1</p> <p>max1 ...limit TK1 T3 ⇨ A1,3 max2 ...limit TK2 T4 ⇨ A2,4</p> <p>Additional: Priority <i>Vorr</i>: (typical: A11, A22, A31, A42)</p>
--	--

$$A1 = T1 > (T3 + \text{diff1}) \ \& \ T3 < \text{max1}$$

$$A2 = T1 > (T4 + \text{diff2}) \ \& \ T4 < \text{max2}$$

$$A3 = T2 > (T3 + \text{diff1}) \ \& \ T3 < \text{max1}$$

$$A4 = T2 > (T4 + \text{diff2}) \ \& \ T4 < \text{max2}$$

Diagram 64

Program 68: Function according to diagram.

The three-way valve **A3** receives power when filling tank **TK2**.

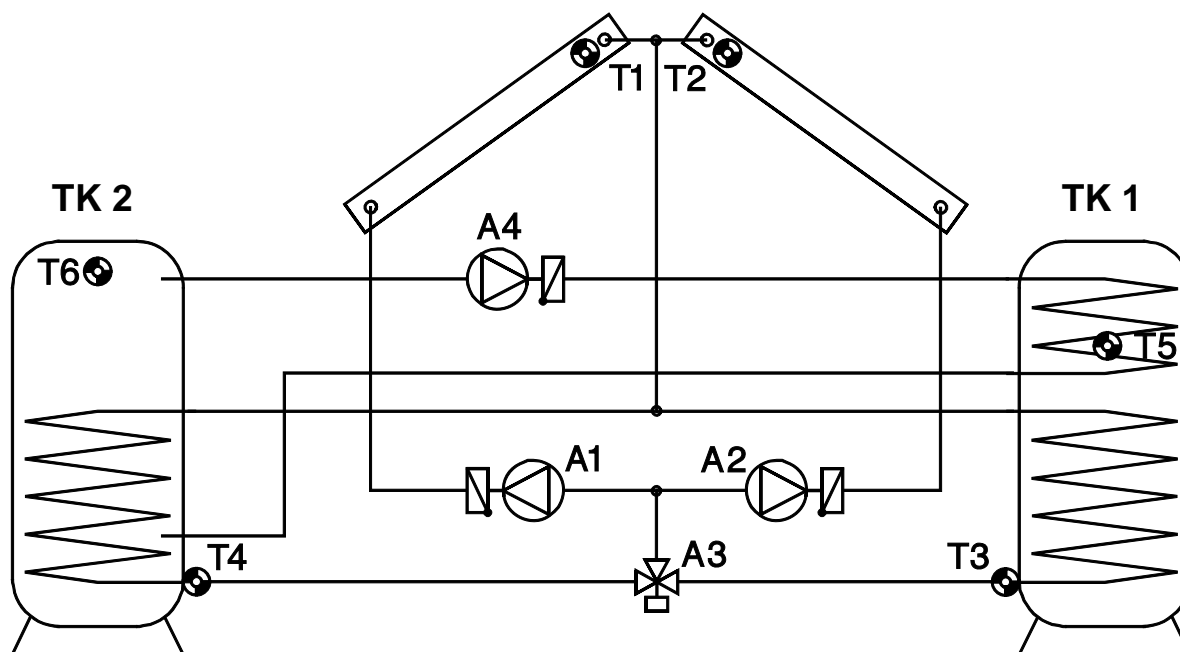

Sensors

- T1.... Collector 1
- T2.... Collector 2
- T3.... Tank 1 bottom
- T4.... Tank 2 bottom
- T5.... Tank 1 top
- T6.... Tank 2 top

Outputs

- A1.... Solar pump collector panel 1
- A2.... Solar pump collector panel 2
- A3.... Three-way valve (feeding tanks)
- A4.... Feed pump

<p>T1</p> <p>diff1 A1</p> <p>diff2 A1,3</p> <p>diff1 A2</p> <p>T3 max1</p>	<p>T2</p> <p>diff2 A2,3</p> <p>diff2 A1,3</p> <p>diff1 A2</p> <p>T4 max2</p>	<p>T6 min2</p> <p>diff4 A4</p> <p>T5 max4</p>	<p>Required settings:</p> <p>diff1 ...coll. T1 – TK1 T3 ⇒ A1 coll. T2 – TK1 T3 ⇒ A2</p> <p>diff2 ...coll. T1 – TK2 T4 ⇒ A1,3 coll. T2 – TK2 T4 ⇒ A2,3</p> <p>diff3 ...see all programs +1</p> <p>diff4 ...TK2 T6 – TK1 T5 ⇒ A4</p> <p>min2 ...switch-on temp. T6 ⇒ A4</p> <p>max1 ...limit TK1 T3 ⇒ A1,2</p> <p>max2 ...limit TK2 T4 ⇒ A1,2,3</p> <p>max4 ...limit TK1 T5 ⇒ A4</p> <p>Additional: Priority Vorr. (typical: A11, A22, A31, A42)</p>
--	--	---	---

$$\begin{aligned}
 A1 &= T1 > (T3 + \text{diff1}) \ \& \ T3 < \text{max1} \\
 A1 \ \& \ A3 &= T1 > (T4 + \text{diff2}) \ \& \ T4 < \text{max2} \\
 A2 &= T2 > (T3 + \text{diff1}) \ \& \ T3 < \text{max1} \\
 A2 \ \& \ A3 &= T2 > (T4 + \text{diff2}) \ \& \ T4 < \text{max2} \\
 A4 &= T6 > (T5 + \text{diff4}) \ \& \ T6 > \text{min2} \ \& \ T5 < \text{max4}
 \end{aligned}$$

All Programs +1: If the difference between collector sensors **T1** and **T2** exceeds the difference **diff3**, the colder collector is switched off. This prevents heat from being lost in the colder collector when temperatures are mixed.

Diagram 80: Layering storage tank, feed pump and domestic hot water preparation

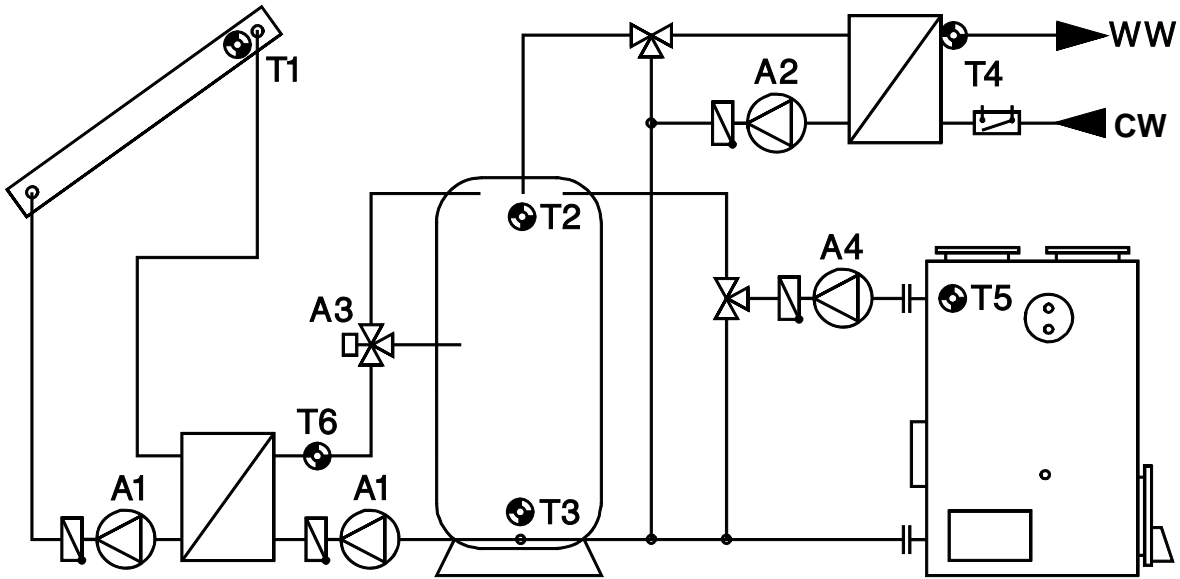

Sensors

- T1.... Collector
- T2.... Tank top
- T3.... Tank bottom
- T4.... Hot water (ultra-fast sensor)
- T5.... Boiler
- T6.... Solar flow

Outputs

- A1.... Solar pumps
- A2.... Heat exchanger pump (hot water)
- A3.... Three-way valve layering storage
- A4.... Feed pump

Program 80: Function according to diagram

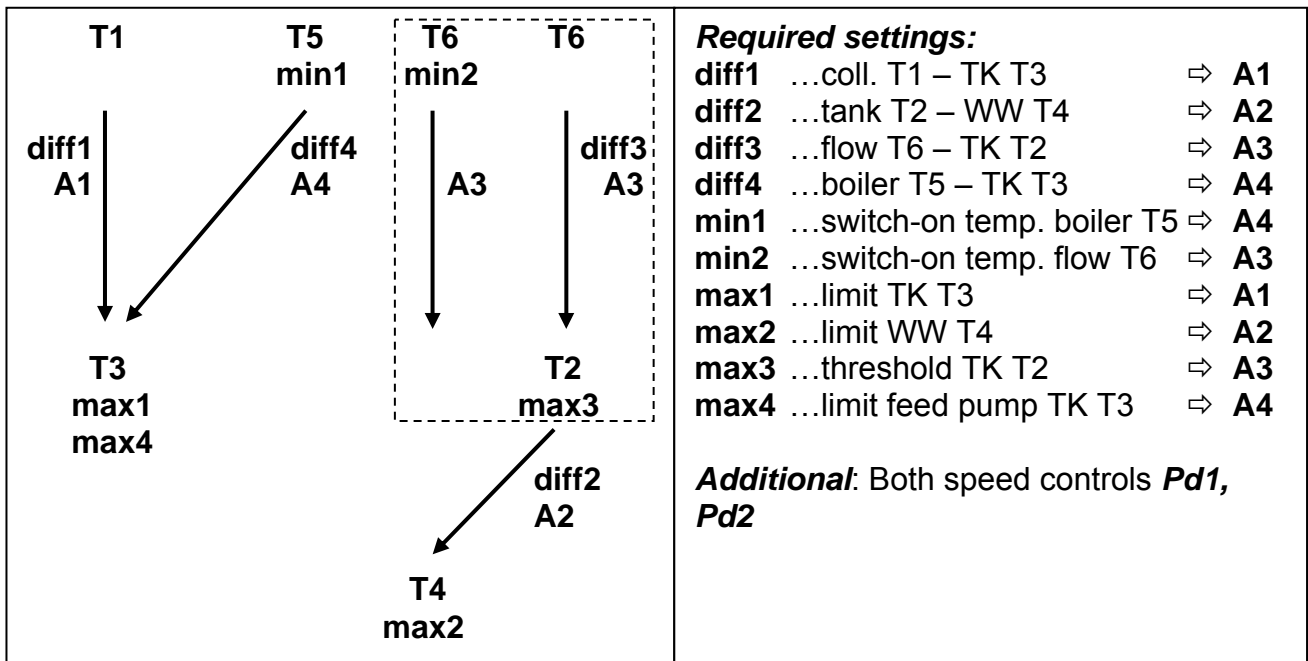

$$A1 = T1 > (T3 + diff1) \ \& \ T3 < max1$$

$$A2 = T2 > (T4 + diff2) \ \& \ T4 < max2$$

$$A3 = (T6 > min2 \ \text{or} \ T6 > (T2 + diff3)) \ \& \ T2 < max3$$

$$A4 = T5 > (T3 + diff4) \ \& \ T5 > min1 \ \& \ T3 < max4$$

Diagram 80

Program 80: Function according to diagram

Both solar pumps are switched on by the difference **diff1**. The three-way valve **A3** switches to the tank top, when **T6** is increasing **min2** or is greater than **T2** by **diff3**, but **T2** has not exceeded the threshold **max3**.

The speed controlled output **A2** is used for domestic hot water preparation. The detection of a flow is possible by using a volume flow switch, electrically switched in series to sensor **T4**.

Sensor **T4** is kept constant by the speed control (absolute value control). When **T2** decreases, the controller keeps the difference between **T2** and **T4** constant (setting of the value **d** in menu speed control) for avoiding the mixing inside the tank because of too high pump speed (differential control). The slower of the two speeds “wins out”.

Program 81: If **T2** has reached **max3**, the quick warm-up phase has been completed, and the speed control for **A1** is thus blocked \Rightarrow optimal efficiency.

Program 82: The speed control for **A1** is blocked, when the three-way valve switches to the bottom (**A3** = off). In this case the priority control is active for the possibility of switching back to the top tank area at high enough solar radiation.

All Programs +4: The domestic hot water preparation is not applicable. **A2** is the secondary pump in the solar loop. **T4** should be mounted in the primary solar loop. **A2** switches, when **A1** is already active and **T4** is greater than **T3** by **diff2**.

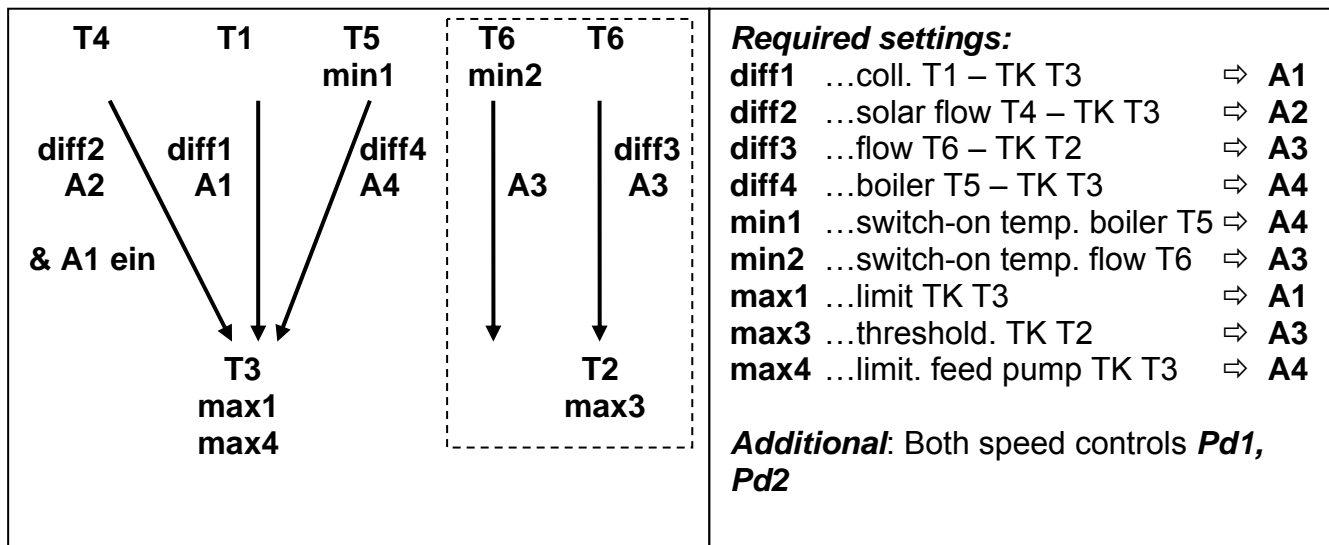

$$A1 = T1 > (T3 + diff1) \ \& \ T3 < max1$$

$$A2 = T4 > (T3 + diff2) \ \& \ (A1 = on)$$

$$A3 = (T6 > min2 \ \underline{or} \ T6 > (T2 + diff3)) \ \& \ T2 < max3$$

$$A4 = T5 > (T3 + diff4) \ \& \ T5 > min1 \ \& \ T3 < max4$$

Program 88: A1 gets additionally the threshold *min1* at T1. The solid fuel boiler is not applicable. The domestic hot water preparation by A2 is also switching, if T4 is greater than T5 by *diff2*. T5 could be a volume flow switch. A4 is used for burner requirement. A4 switches when T2 has not exceeded *max4*.

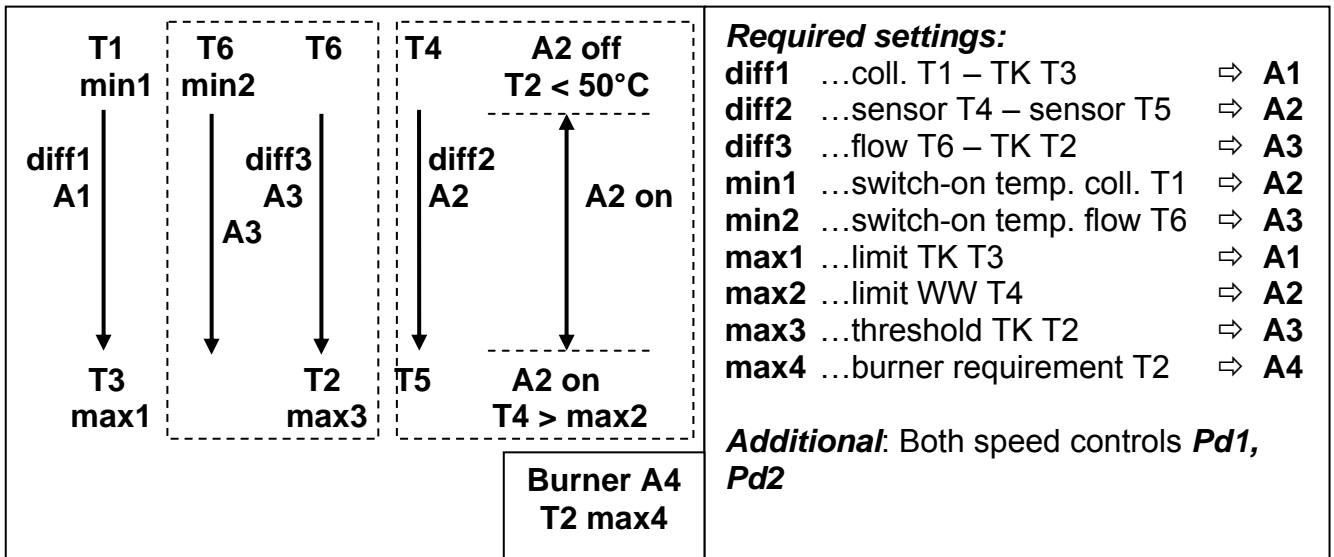

$$\begin{aligned}
 A1 &= T1 > min1 \ \& \ T1 > (T3 + diff1) \ \& \ T3 < max1 \\
 A2 &= T4 > (T5 + diff2) \ \underline{or} \ (T2 > 50^{\circ}C \ \& \ T4 < max2) \\
 A3 &= (T6 > min2 \ \underline{or} \ T6 > (T2 + diff3)) \ \& \ T2 < max3 \\
 A4 \ (on) &= T2 < max4 - hysteresis \\
 A4 \ (off) &= T2 > max4
 \end{aligned}$$

Program 89: according to program 88, but: If T4 has reached *max3*, the quick warm-up phase has been completed, and the speed control of A1 is thus blocked ⇒ optimal efficiency.

Program 92: according to program 88, but: the changing between tank center and top is done by a thermic valve. Therefore A3 is free for an additional feed pump function. A3 switches when T6 is increasing *min2* and is greater than T3 by *diff3* and T3 has not exceeded *max3*.

$$\begin{aligned}
 A1 &= T1 > min1 \ \& \ T1 > (T3 + diff1) \ \& \ T3 < max1 \\
 A2 &= T4 > (T5 + diff2) \ \underline{or} \ (T2 > 50^{\circ}C \ \& \ T4 < max2) \\
 A3 &= T6 > min2 \ \& \ T6 > (T3 + diff3) \ \& \ T3 < max3 \\
 A4 \ (on) &= T2 < max4 - hysteresis \\
 A4 \ (off) &= T2 > max4
 \end{aligned}$$

Program 94: according to program 92, but: the sensor T2 in the tank top is used for the feed pump function A3. Therefore this function is better suitable for oil or gas boilers.

$$\begin{aligned}
 A1 &= T1 > min1 \ \& \ T1 > (T3 + diff1) \ \& \ T3 < max1 \\
 A2 &= T4 > (T5 + diff2) \ \underline{or} \ (T2 > 50^{\circ}C \ \& \ T4 < max2) \\
 A3 &= T6 > min2 \ \& \ T6 > (T2 + diff3) \ \& \ T2 < max3. \\
 A4 \ (on) &= T2 < max4 - hysteresis \\
 A4 \ (off) &= T2 > max4
 \end{aligned}$$

Diagram 96

Diagram 96: Solar power system with two consumers and two feed pump functions

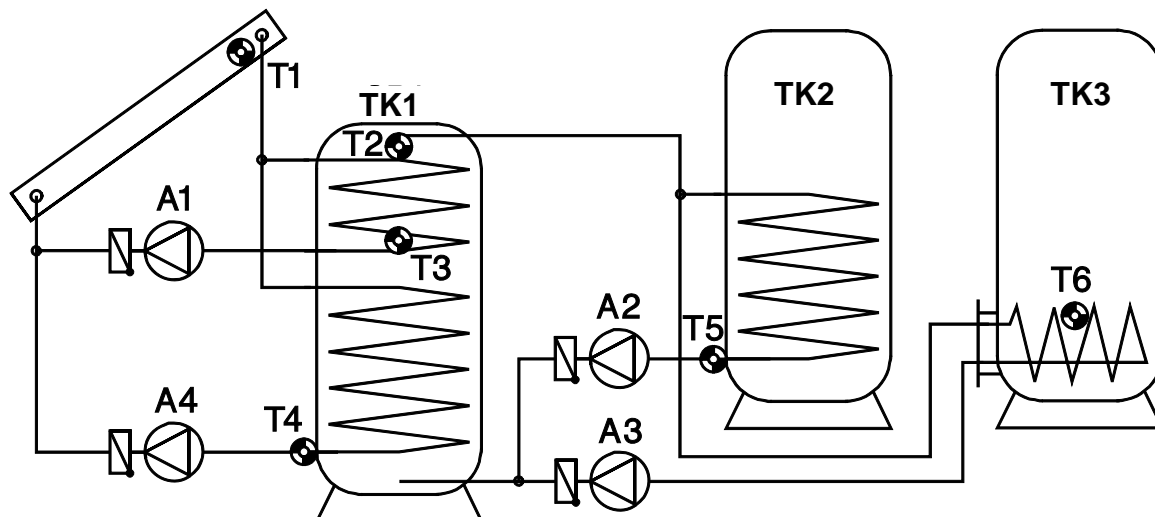

Sensors

T1.... Collector
 T2.... Tank TK1 top
 T3.... Tank TK1 center
 T4.... Tank TK1 bottom
 T5.... Tank TK2 bottom
 T6.... Tank TK3 bottom

Outputs

A1.... Solar pump loop 1
 A2.... Feed pump TK2
 A3.... Feed pump TK3
 A4.... Solar pump loop 2

Program 96: Function according to diagram.

<p>T1 min1</p> <p>diff1 A1</p> <p>diff4 A4</p> <p>T3 max1</p> <p>T4 max4</p> <p>T2 min2</p> <p>diff2 A2</p> <p>diff3 A3</p> <p>T5 max2</p> <p>T6 max3</p>	<p>Required settings:</p> <p>diff1 ...coll. T1 – TK1 T3 ⇨ A1</p> <p>diff2 ...TK 1 T2 – TK 2 T5 ⇨ A2</p> <p>diff3 ...TK 1 T2 – TK 3 T6 ⇨ A3</p> <p>diff4 ...Coll. T1 – TK 1 T4 ⇨ A4</p> <p>min1 ...switch-on temp. coll. T1 ⇨ A1,4</p> <p>min2 ...switch-on temp. TK 1 T2 ⇨ A2,3</p> <p>max1 ...limit TK1 T3 ⇨ A1</p> <p>max2 ...limit TK2 T5 ⇨ A2</p> <p>max3 ...limit TK3 T6 ⇨ A3</p> <p>max4 ...limit TK1 T4 ⇨ A4</p> <p>Additional: Priority Vorr. (typical: A11, A20, A30, A42)</p>
---	--

$$\begin{aligned}
 A1 &= T1 > (T3 + \text{diff1}) \ \& \ T1 > \text{min1} \ \& \ T3 < \text{max1} \\
 A2 &= T2 > (T5 + \text{diff2}) \ \& \ T2 > \text{min2} \ \& \ T5 < \text{max2} \\
 A3 &= T2 > (T6 + \text{diff3}) \ \& \ T2 > \text{min2} \ \& \ T6 < \text{max3} \\
 A4 &= T1 > (T4 + \text{diff4}) \ \& \ T1 > \text{min1} \ \& \ T4 < \text{max4}
 \end{aligned}$$

Diagram 96

Program 97: Instead of the two **solar pumps**, one pump and a three-way valve are used (pump-valve system). The speed control (if activated) only operated when filling **loop 1 (T3)**.

A1... common pump

A4... Valve (A4/S receives power when filling tank **TK1** bottom)

All Programs +2: Instead of the two **feed pumps**, one pump and a three-way valve are used (pump-valve system). The speed control (if activated) only operated when filling **loop TK2 (T5)**.

A2... common pump

A3... Valve (A3/S receives power when filling tank **TK3**)

Diagram A0

All Programs +1: Instead of the two solar pumps, one pump and a three-way valve are used (pump-valve system). The speed control (if activated) only operated when filling TK 1 (T3).

A1... common pump

A2... Valve (A2/S receives power when filling tank TK2)

All Programs +2: Output **A4** is used for burner requirement with separated on and off thresholds instead of feed pump function.

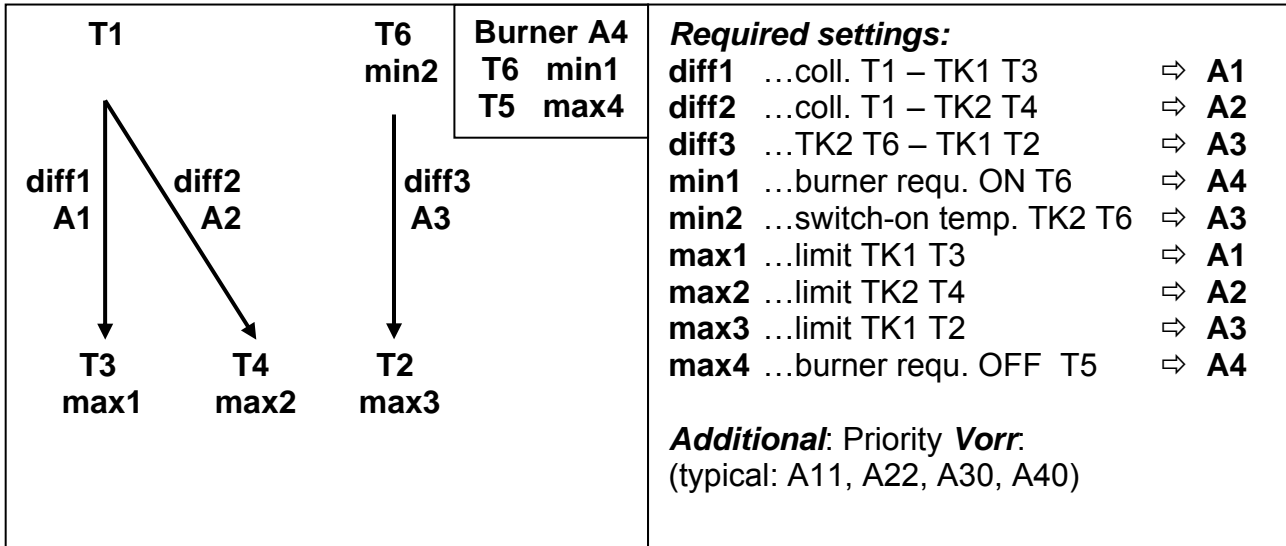

$$A1 = T1 > (T3 + \text{diff1}) \ \& \ T3 < \text{max1}$$

$$A2 = T1 > (T4 + \text{diff2}) \ \& \ T4 < \text{max2}$$

$$A3 = T6 > (T2 + \text{diff3}) \ \& \ T6 > \text{min2} \ \& \ T2 < \text{max3}$$

$$A4 \text{ (on)} = T6 < \text{min1} \quad A4 \text{ (off)} = T5 > \text{max4}$$

Program A4: The feed pump function of output **A4** is active between boiler **T5** and tank 1 **T2**.

$$A1 = T1 > (T3 + \text{diff1}) \ \& \ T3 < \text{max1}$$

$$A2 = T1 > (T4 + \text{diff2}) \ \& \ T4 < \text{max2}$$

$$A3 = T6 > (T2 + \text{diff3}) \ \& \ T6 > \text{min2} \ \& \ T2 < \text{max3}$$

$$A4 = T5 > (T2 + \text{diff4}) \ \& \ T5 > \text{min1} \ \& \ T2 < \text{max4}$$

Program A6: Burner requirement **A4** (on), when **T5** < *min1*

Burner requirement **A4** (off), when **T2** > *max4*

$$A1 = T1 > (T3 + \text{diff1}) \ \& \ T3 < \text{max1}$$

$$A2 = T1 > (T4 + \text{diff2}) \ \& \ T4 < \text{max2}$$

$$A3 = T6 > (T2 + \text{diff3}) \ \& \ T6 > \text{min2} \ \& \ T2 < \text{max3}$$

$$A4 \text{ (on)} = T5 < \text{min1} \quad A4 \text{ (off)} = T2 > \text{max4}$$

Diagram B0

Diagram B0: Solar power system, 2 feed pump functions, burner requirement

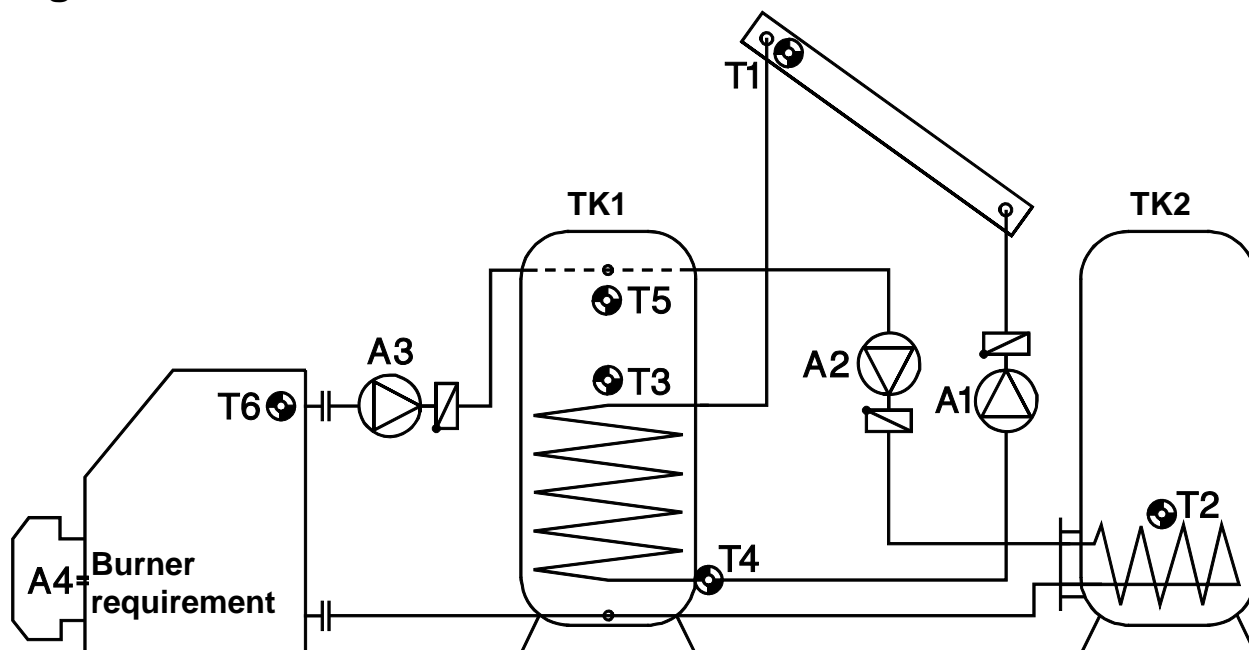

Sensors

T1.... Collector
 T2.... Tank TK2 bottom
 T3.... Tank TK1 center
 T4.... Tank TK1 bottom
 T5.... Tank TK1 top
 T6.... Boiler

Outputs

A1.... Solar pump
 A2.... Feed pump TK2
 A3.... Feed pump TK1
 A4.... Burner requirement

Program B0: Function according to diagram.

<p>T1</p> <p>↓</p> <p>diff1 A1</p> <p>↓</p> <p>T4 max1</p>	<p>T5 min1</p> <p>↓</p> <p>diff2 A2</p> <p>↓</p> <p>T2 max2</p>	<p>T6 min2</p> <p>↓</p> <p>diff3 A3</p> <p>↓</p> <p>T3 max3</p>	<p>Burner A4 T5 max4</p>	<p>Required settings:</p> <p>diff1 ...coll. T1 – TP1 T4 ⇒ A1</p> <p>diff2 ...TK1 top T5 – TK2 T2 ⇒ A2</p> <p>diff3 ...boiler T6 – TK1 T3 ⇒ A3</p> <p>diff4 ...see all programs +1</p> <p>min1 ...switch-on temp. TK1 T5 ⇒ A2</p> <p>min2 ...switch-on temp. boiler T6 ⇒ A3</p> <p>max1 ...limit TK1 T4 ⇒ A1</p> <p>max2 ...limit TK2 T2 ⇒ A2</p> <p>max3 ...limit TK1 T3 ⇒ A3</p> <p>max4 ...burner requirement T5 ⇒ A4</p>
--	---	---	------------------------------	--

$$A1 = T1 > (T4 + \text{diff1}) \ \& \ T4 < \text{max1}$$

$$A2 = T5 > (T2 + \text{diff2}) \ \& \ T5 > \text{min1} \ \& \ T2 < \text{max2}$$

$$A3 = T6 > (T3 + \text{diff3}) \ \& \ T6 > \text{min2} \ \& \ T3 < \text{max3}$$

$$A4 \text{ (on)} = T5 < \text{max4} - \text{hysteresis}$$

$$A4 \text{ (off)} = T5 > \text{max4}$$

Diagram B0

All Programs +1: The feeding of the hot water tank is normally done by the difference buffer **T5** – hot water tank **T2**. This program considers also the boiler temperature **T6**.

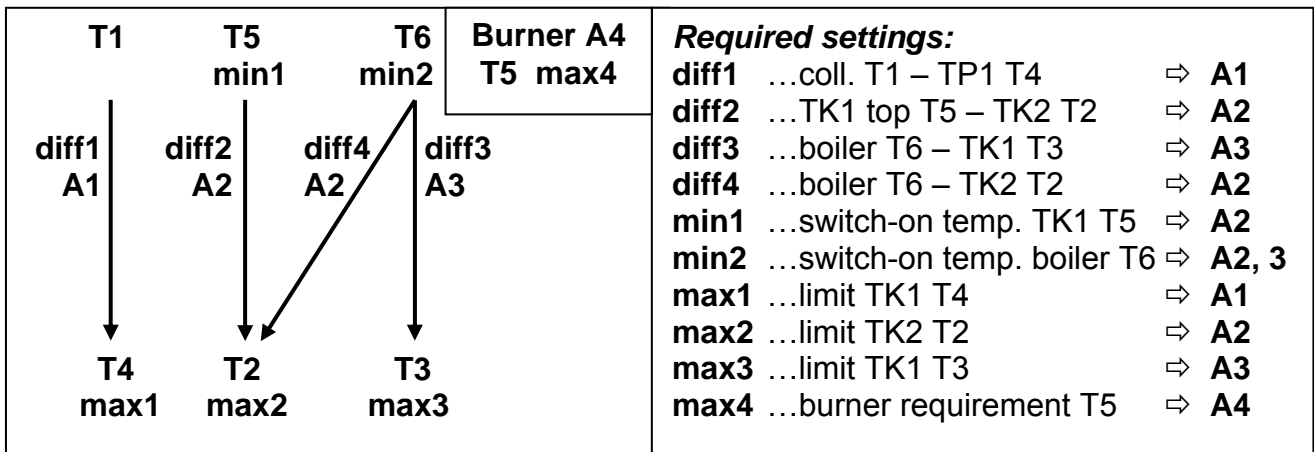

$$\begin{aligned}
 A1 &= T1 > (T4 + diff1) \ \& \ T4 < max1 \\
 A2 &= T5 > (T2 + diff2) \ \& \ T2 < max2 \ \& \ T5 > min1 \\
 \text{or} \quad & T6 > (T2 + diff4) \ \& \ T2 < max2 \ \& \ T6 > min2 \\
 A3 &= T6 > (T3 + diff3) \ \& \ T3 < max3 \ \& \ T6 > min2 \\
 A4 \text{ (on)} &= T5 < max4 - hysteresis \\
 A4 \text{ (off)} &= T5 > max4
 \end{aligned}$$

All Programs +2: Separated on and off thresholds for the burner requirement

$$\begin{aligned}
 A3 &= T6 > (T3 + diff3) \ \& \ T6 > min2 \\
 A4 \text{ (on)} &= T5 < max3 \\
 A4 \text{ (off)} &= T3 > max4
 \end{aligned}$$

All Programs +4: Diagram with solid fuel boiler instead of a solar power system. The threshold **min1** affects not at **T5** but at **T1**.

Diagram C0

Diagram C0: Solar power system with 3 consumers, bypass function

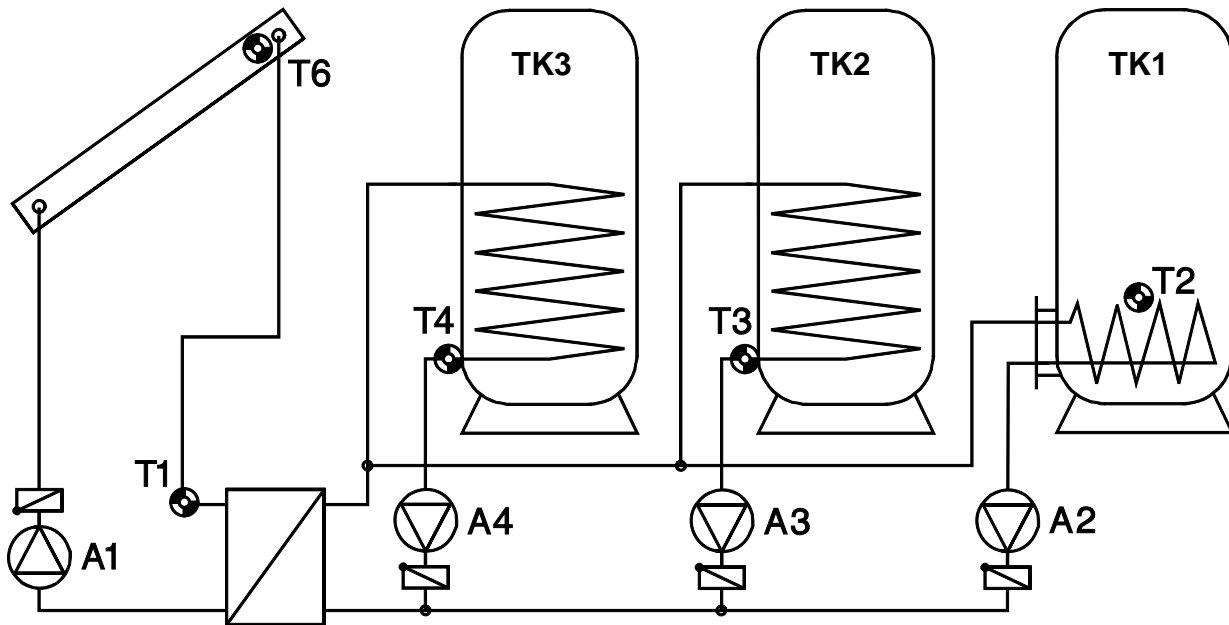

Sensors

- T1.... Flow solar loop
- T2.... Tank TK1
- T3.... Tank TK2
- T4.... Tank Tk3
- T5.... Freely usable
- T6.... Collector

Outputs

- A1.... Primary solar pump
- A2.... Solar pump TK1
- A3.... Solar pump TK2
- A4.... Solar pump TK3

Program C0: Function according to diagram. The primary and the secondary side are separated hydraulically. The secondary pumps are switched separated from the primary pumps.

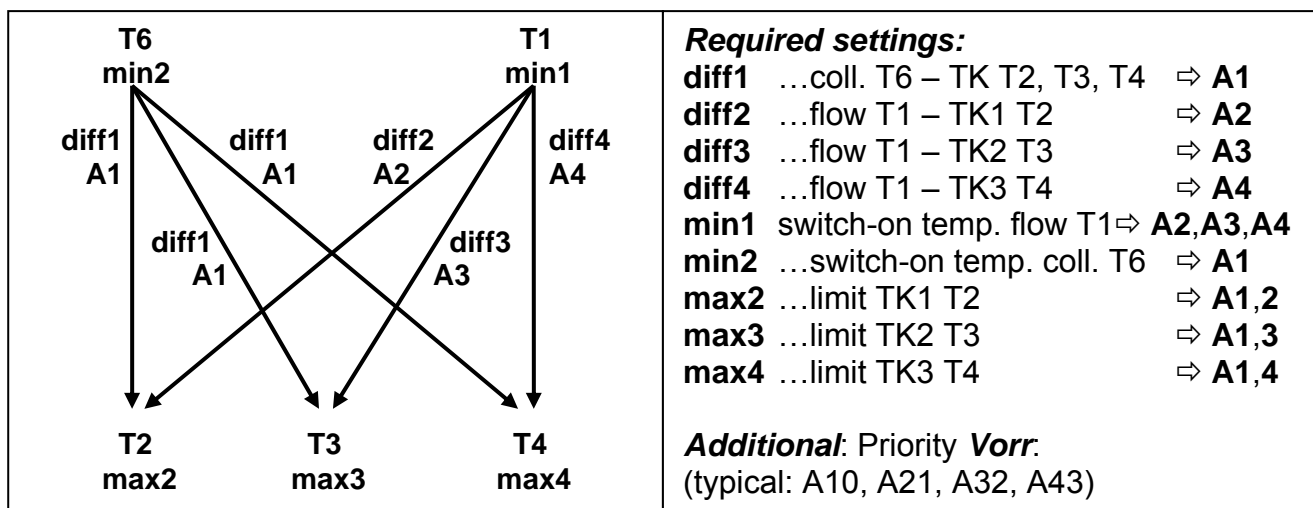

$$\begin{aligned}
 A1 &= (T6 > (T2 + \text{diff1}) \text{ or } T6 > (T3 + \text{diff1}) \text{ or } T6 > (T4 + \text{diff1})) \\
 &\quad \& T6 > \text{min2} \& (T2 < \text{max2} \text{ or } T3 < \text{max3} \text{ or } T4 < \text{max4}) \\
 A2 &= T1 > (T2 + \text{diff2}) \& T1 > \text{min1} \& T2 < \text{max2} \\
 A3 &= T1 > (T3 + \text{diff3}) \& T1 > \text{min1} \& T3 < \text{max3} \\
 A4 &= T1 > (T4 + \text{diff4}) \& T1 > \text{min1} \& T4 < \text{max4}
 \end{aligned}$$

All Programs +1:

Instead of both pumps **A2** and **A3** one pump **A2** and a three-way valve **A3** are deployed. (pump-valve system between TK1 and TK2).

A2... common pump or bypass valve

A3... Valve (A3/S receives power when filling tank **TK2 (T3)**)

All Programs +2:

Instead of both pumps **A2** and **A4** one pump **A2** and a three-way valve **A4** are deployed. (pump-valve system between TK1 and TK3).

A2... common pump or bypass valve

A4... Valve (A4/S receives power when filling tank **TK3 (T4)**)

All Programs +4: If all of the tanks have reached their maximum temperature, loading to **TK2 (T3)** continues regardless of *max3*.

Diagram D0

Diagram D0: Simple solar power system, 2 feed pumps, feed pump for domestic hot water tank

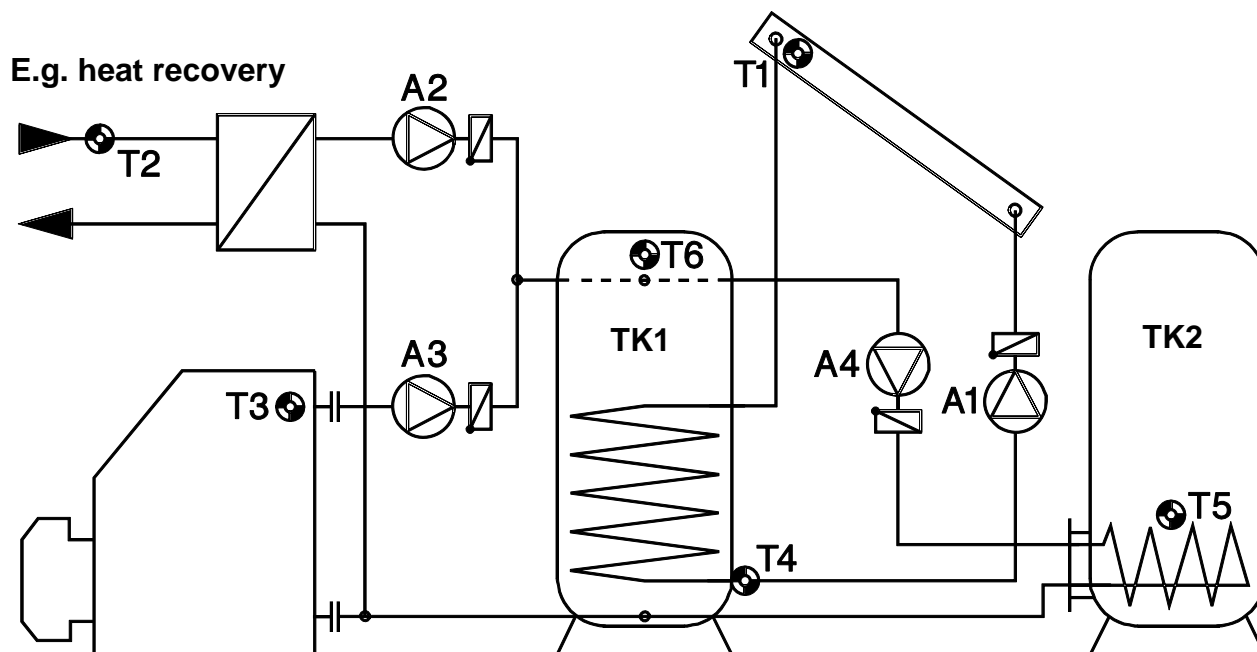

Sensors

- T1.... Collector
- T2.... Heat source
- T3.... Boiler
- T4.... Tank TK1 bottom
- T5.... Tank TK2 bottom
- T6.... Tank TK1 top

Outputs

- A1.... Solar pump
- A2.... Feed pump TK1
- A3.... Feed pump TK1
- A4.... Feed pump TK2

Program D0: Function according to diagram.

<p>T1</p> <p>T2 min1</p> <p>T3 min2</p> <p>T6</p> <p>diff1 A1</p> <p>diff2 A2</p> <p>diff3 A3</p> <p>diff4 A4</p> <p>T4 max1 max2 max3</p> <p>T5 max4</p>	<p>Required settings:</p> <p>diff1 ...coll. T1 – SP1 T4 ⇒ A1</p> <p>diff2 ...heat source T2 – TK1 T4 ⇒ A2</p> <p>diff3 ...boiler T3 – TK1 T4 ⇒ A3</p> <p>diff4 ...TK1 T6 – TK2 T5 ⇒ A4</p> <p>min1 ...heat source T2 ⇒ A2</p> <p>min2 ...boiler T3 ⇒ A3</p> <p>max1 ...limit TK1 T4 ⇒ A1</p> <p>max2 ...limit TK1 T4 ⇒ A2</p> <p>max3 ...limit TK1 T4 ⇒ A3</p> <p>max4 ...limit TK2 T5 ⇒ A4</p>
---	--

$$\begin{aligned}
 A1 &= T1 > (T4 + \text{diff1}) \ \& \ T4 < \text{max1} \\
 A2 &= T2 > (T4 + \text{diff2}) \ \& \ T2 > \text{min1} \ \& \ T4 < \text{max2} \\
 A3 &= T3 > (T4 + \text{diff3}) \ \& \ T3 > \text{min2} \ \& \ T4 < \text{max3} \\
 A4 &= T6 > (T5 + \text{diff4}) \ \& \ T5 < \text{max4}
 \end{aligned}$$

Program D1: Threshold *min2* is active at sensor **T6** and switches output **A4**.

Program D2: instead of the independent temperature difference between **T6** and **T5** the difference between **T6** and **T4** applies. Hence it is possible to heat one consumer from four generators.

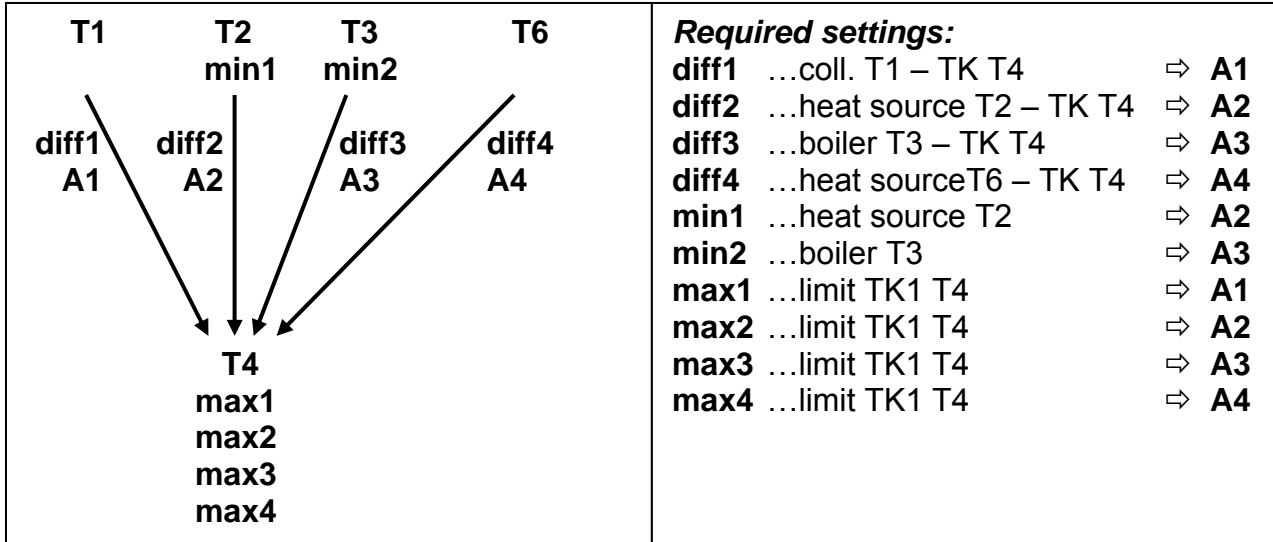

$$A4 = T6 > (T4 + diff4) \ \& \ T4 < max4$$

Program D4: Sensor **T3** will be compared with **T5** additionally to sensor **T4**. Hence the boiler can feed tank **TK1** (**T4**) as well as tank **TK2** (**T5**).

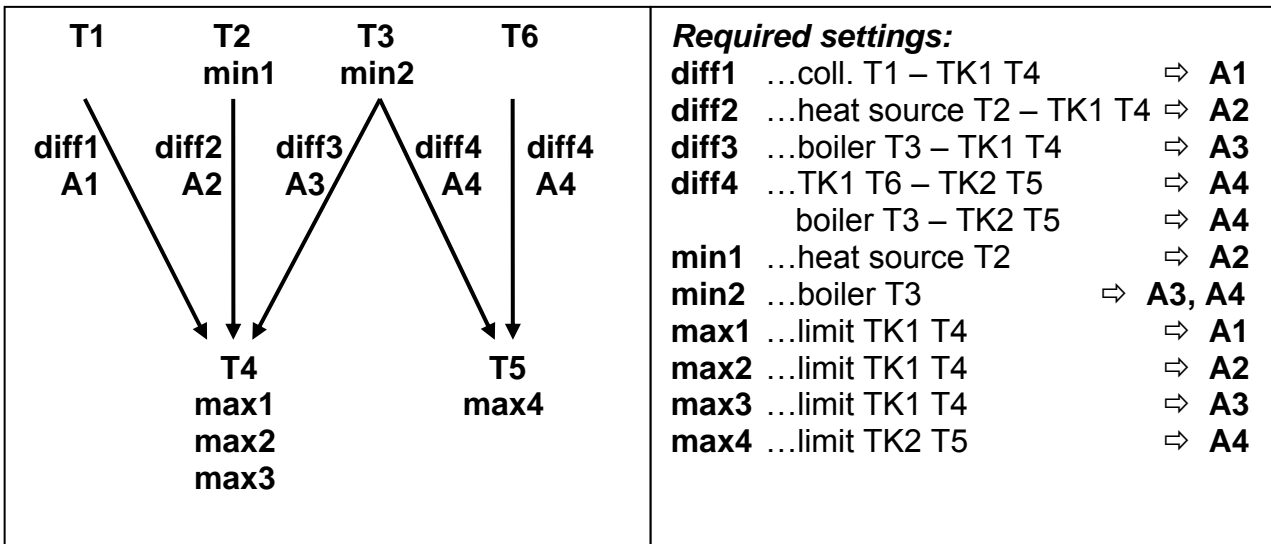

$$A1 = T1 > (T4 + diff1) \ \& \ T4 < max1$$

$$A2 = T2 > (T4 + diff2) \ \& \ T2 > min1 \ \& \ T4 < max2$$

$$A3 = T3 > (T4 + diff3) \ \& \ T3 > min2 \ \& \ T4 < max3$$

$$A4 = T6 > (T5 + diff4) \ \& \ T5 < max4$$

or

$$T3 > (T5 + diff4) \ \& \ T3 > min2 \ \& \ T5 < max4$$

Diagram D0

Program D5: Instead of the independent temperature difference $T6 - T5$ the controller compares the sensors $T6$ and $T3$.

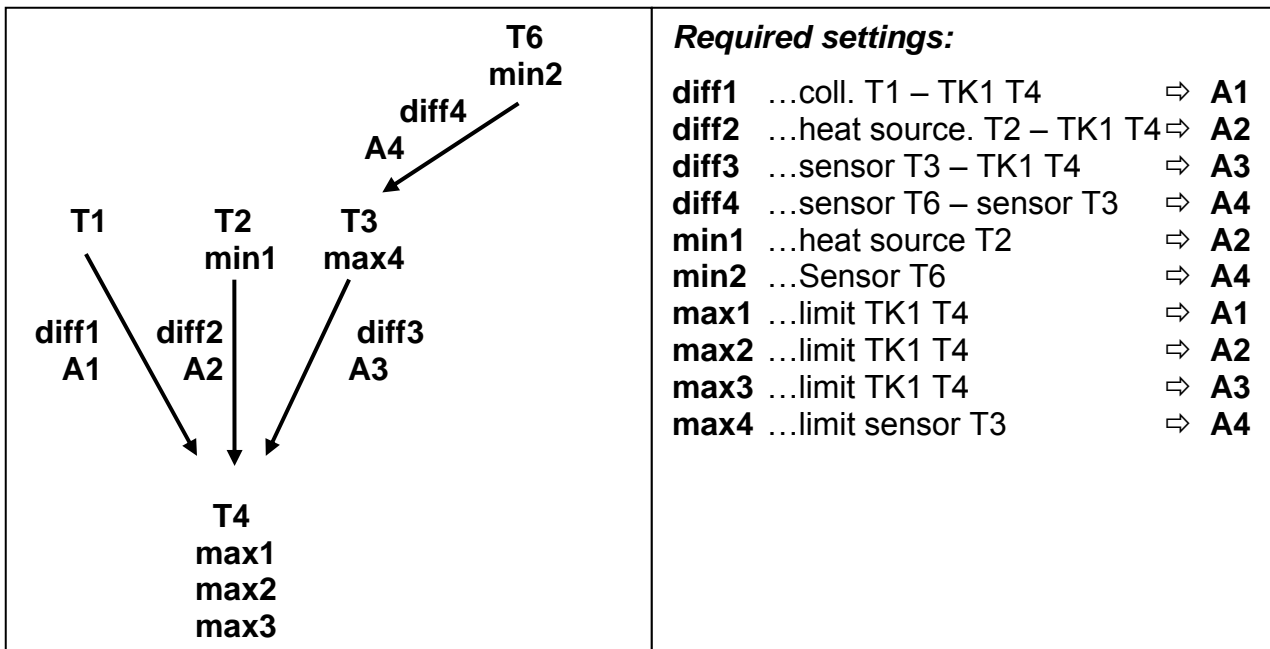

$$A1 = T1 > (T4 + \text{diff1}) \ \& \ T4 < \text{max1}$$

$$A2 = T2 > (T4 + \text{diff2}) \ \& \ T2 > \text{min1} \ \& \ T4 < \text{max2}$$

$$A3 = T3 > (T4 + \text{diff3}) \ \& \ T4 < \text{max3}$$

$$A4 = T6 > (T3 + \text{diff4}) \ \& \ T6 > \text{min2} \ \& \ T3 < \text{max4}$$

Program D6: Output **A4** switches only because of the following function.

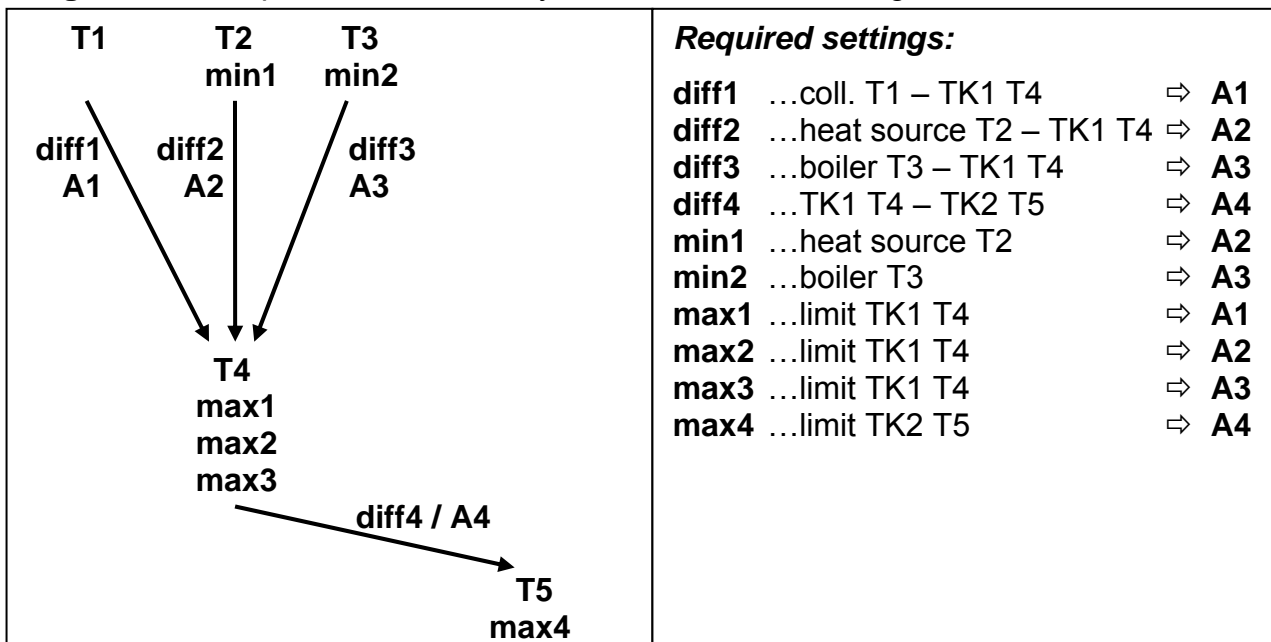

$$A1 = T1 > (T4 + \text{diff1}) \ \& \ T4 < \text{max1}$$

$$A2 = T2 > (T4 + \text{diff2}) \ \& \ T2 > \text{min1} \ \& \ T4 < \text{max2}$$

$$A3 = T3 > (T4 + \text{diff3}) \ \& \ T3 > \text{min2} \ \& \ T4 < \text{max3}$$

$$A4 = T4 > (T5 + \text{diff4}) \ \& \ T5 < \text{max4}$$

Program D7: Outputs **A3** and **A4** switch only because of the following function.

$$A3 = T3 > (T4 + \text{diff3}) \ \& \ T4 < \text{max3}$$

$$A4 = T4 > (T5 + \text{diff4}) \ \& \ T4 > \text{min2} \ \& \ T5 < \text{max4}$$

Installing instructions

Installing the sensor(s):

The sensors must be arranged and installed properly for the system to function correctly. To this end, make sure that they are completely inserted in the immersion sleeves. The threaded cable connections provided can be used to provide strain relief. The clip-on sensors must be insulated to protect them from being influenced by the ambient temperature. Water must be kept out of the immersion sleeves when used outdoors (**damage from freezing**).

In general, the sensors may not be exposed to moisture (such as condensation water), which might enter the cast resin and damage the sensor. If this happens, heating the sensor to 90°C for an hour might help. When using immersion sleeves in NIRO tanks (inoxidable) or pools, pay attention to their **non-corrosion properties**.

- ◆ **Collector sensor (red or black cable with connection box):** Insert either in the tube directly soldered or riveted to the absorber and sticking out of the collector's frame or in a t-shaped connector on the outer collector's supply line collector tube. Screw an immersion sleeve with an MS (brass) threaded cable connection (= to protect from moisture) into this T-shaped connector and insert the sensor. To protect from lightning, the connection box has parallel overvoltage protection between the sensor and the extension cable.
- ◆ **Boiler sensor (boiler supply line):** This sensor is either screwed into the boiler with an immersion sleeve or attached to the boiler's supply line at a slight distance.
- ◆ **Tank sensor:** The sensor that the solar power system needs should be used with an immersion sleeve for fin coil heat exchangers just above the exchanger or, if integrated bare-tube heat exchangers are used, on the lower third of the exchanger or the exchanger's return line so that the immersion sleeve is inside the exchanger's tube. The sensor that monitors the heating of the tank from the boiler is installed at the level of the desired amount of hot water during the heating season. The plastic threaded cable connections provided can be used to provide strain relief. They must not be installed below the register / exchanger.
- ◆ **Buffer sensor:** The sensor that the solar power system needs is installed on the bottom of the tank just below the solar heat exchanger using the immersion sleeve provided. The plastic threaded cable connections provided can be used to provide strain relief. It is recommended that the sensor be used between the middle and the upper third of the buffer tank using the immersion sleeve as a reference sensor for the heater's hydraulics or - flush with the tank's wall - under the insulation.
- ◆ **Pool sensor (swimming pool):** Put a T-shaped connector on the suction line immediately on the line leading from the pool and screw the sensor in with an immersion sleeve. In the process, make sure that the material used is non-corroding. Another option is to put the sensor on the same spot using hose clamps or adhesive tape and to provide thermal insulation for ambient influences.
- ◆ **Clip-on sensor:** Use pipe clamps, hose clamps, and the like must be attached to the respective line. Make sure that suitable material is used (corrosion and temperature resistance, etc.). Then, the sensor has to be well insulated so that the tube temperature can be taken exactly and influences from the ambient temperature can be ruled out.

Installing instructions

- ◆ **Hot water sensor:** When the control system is used in hot water systems with an external heat exchanger and variable-speed pump, changes in the amount of temperature have to be **reacted to quickly**. Hence, the hot water sensor has to be put directly on the heat exchanger's outlet. A t-shaped connector should be used to insert the ultrafast sensor (special accessory) in the outlet using an O-ring along the NIRO tube (inoxidable). The heat exchanger has to be installed upright with the hot water outlet on top.
- ◆ **Radiation sensor:** To get a measurement according to the collector's position, it should be parallel to the collector. It should thus be screwed onto the metal sheet or next to the collector along an extension of the assembly rail. To this end, the sensor case has a blind hole that can be opened at any time.

Line extension

All of the sensor cables with a cross-section of 0.75mm^2 can be extended up to 30m. Beyond 30m they can be extended by use of a suitably larger cross section. The sensor and the probe can be connected by putting the heat-shrinkable sleeve truncated to 4 cm over a wire and twisting the bare ends. Then the heat-shrinkable sleeve is put over the bare, twisted ends and carefully heated (such as with a lighter) until it has wrapped the connection tightly.

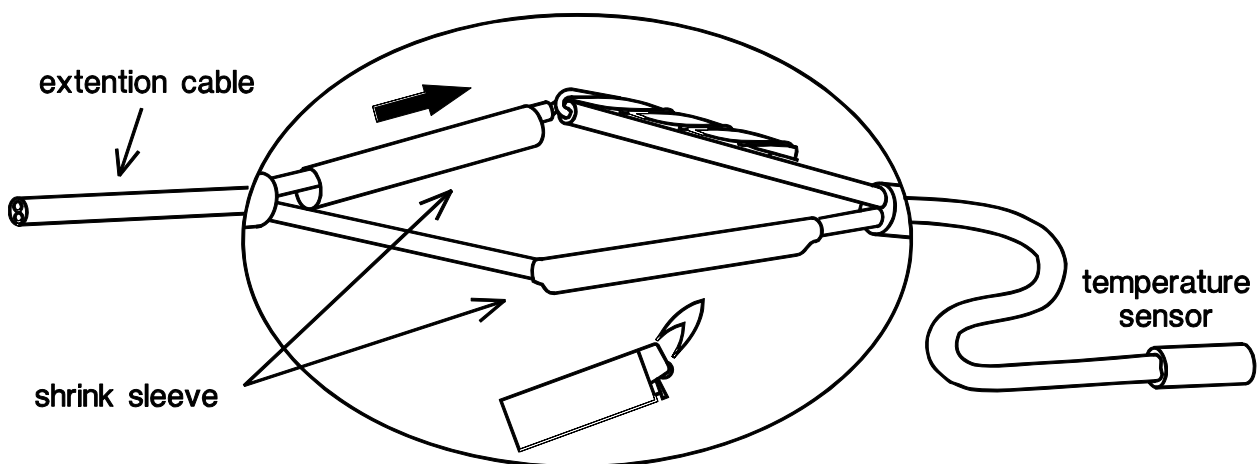

Cable laying

In order to obtain interference-free signal transmission (to avoid measurement fluctuations) the sensor lines must not be subject to interference factors. With the generally accepted use of unshielded cables sensor lines are to be laid in their own cable channel at least 20 cm away from mains cables.

Installing the unit

CAUTION! ALWAYS PULL THE MAINS PLUG BEFORE OPENING THE CASE!

Unscrew the 4 screws at the edges of the case. The controlling electronic is situated in the cover plate and is connected by a ribbon cable to the mains module, which is set in the basin of the case. The basin of the case can be screwed on through the two holes to the wall using the fastening screws provided (**with the cable bushings downwards**). For easier handling the mains module can be taken out of the case.

Electrical connection:

Warning: The electrical connection should only be made by a professional electrician in accordance with the relevant local guidelines. The sensor lines may not be fed through the same cable channel as the supply voltage.

Attention: Only work on the control system when it is dead. Assembling the device should always be done without tension.

All sensors and pumps resp. valves must be connected to the controller according to the numbering of the chosen diagram.

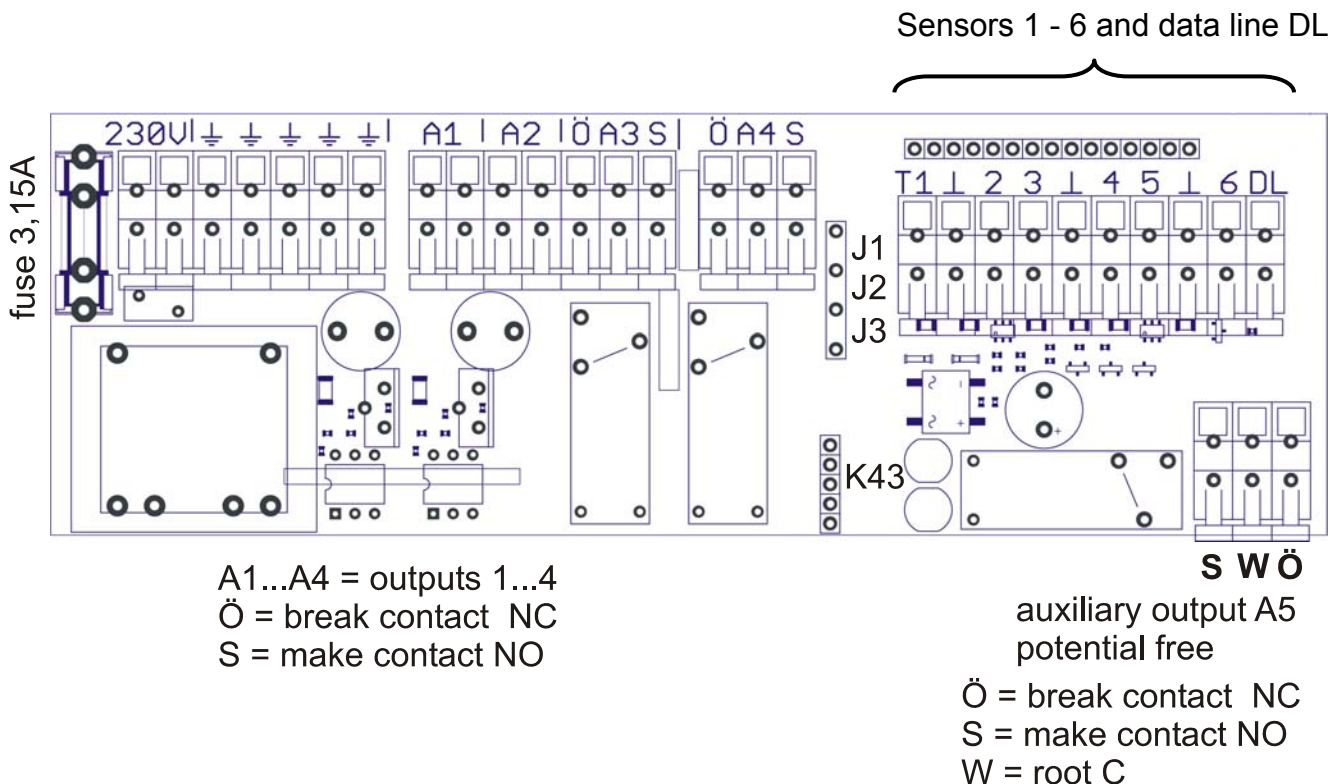

The relay output A4 can be made potential-free by setting the **jumpers J1-J2-J3**. For this purpose the jumper J2 must be set in the center instead of jumpers J1 and J3 (standard).

All sensor ground wires are internally looped and can be exchanged as need be.

Installing instructions

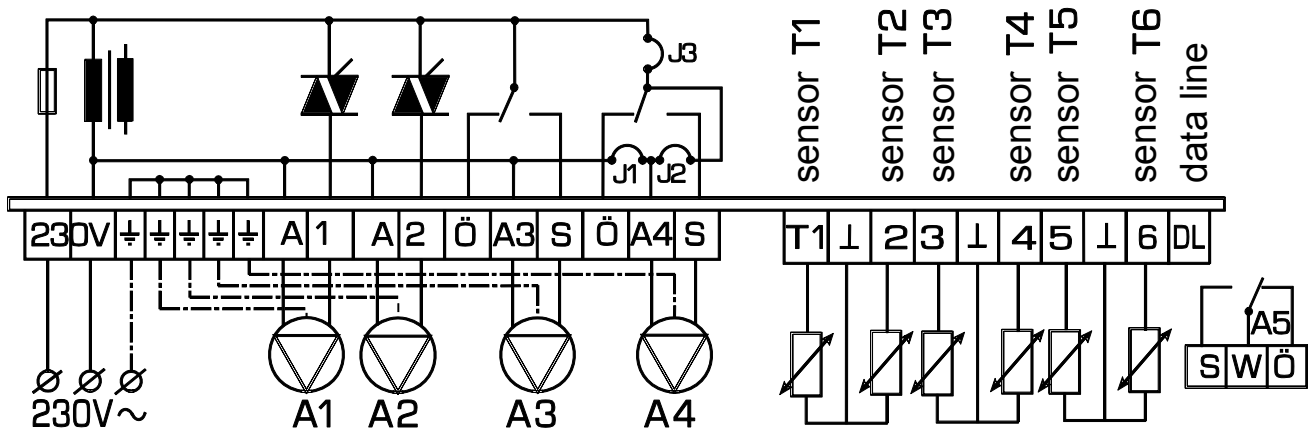

W..... root C

S..... make contact NO

Ö.....break contact NC

Note: The system has to be grounded properly to protect it from damage due to lightning. Sensor failures due to storms and static electricity are usually the result of improper grounding.

Data line (DL)

The data line was specially developed for the UVR series and is only compatible with the products of Technische Alternative. It is only made for generating outputs and is suitable as interface to the PC for transferring the measured temperatures and output states.

Any cable with a cross section of 0.75 mm² can be used for the data link (e.g. twin-strand) having a max. length of 30 m. For longer cables, we recommend the use of shielded cable.

Interface to PC: The data is cached via the data converter **D-LOGG** or boot loader **BL-NET** and transferred to the PC on request. An individual power pack (CAN-NT) is necessary for supplying power to the **BL-NET**!

Selector switch

The selector switch has 16 different positions. Each position has two functions (e.g. switch position **diff2 / T2**). The value, which is nearer to the selector switch, will be displayed without pressing of the yellow key "**Eingabe**" (e.g. **T2**). By pressing the yellow key "**Eingabe**" (= input) the second value will be displayed (e.g. **diff2**). The blue keys "**ab**" (= down) resp. "**auf**" (= up) change the settings. Holding the key pressed increases resp. decreases constantly the value, short taps cause a change of 1.

The interior legend (e.g. **T5** = displayed temperature of sensor 5) has **no direct connection** to the outside legend (e.g. **min1** = temperature limit of the tank). E.g. in diagram 0 the sensor **T5** has connection with **min1**, but **T3** corresponds with **max1**.

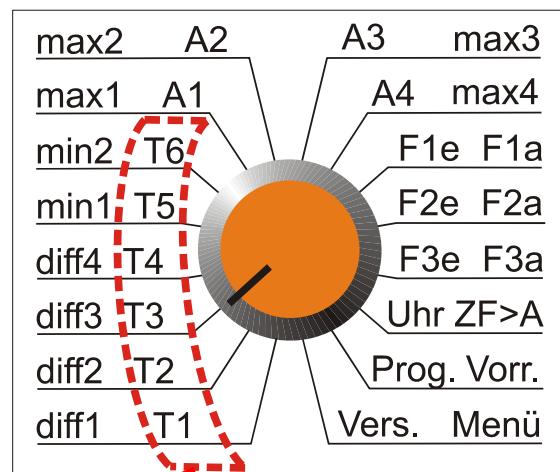

T1 - T6	Actual temperature of the sensors
A1 - A4	State of the outputs („Ein“ = ON, „Aut“ = automatic mode, „Aus“ = OFF) The changing occurs by pressing the blue keys <i>ab/auf</i> (down/up).
diff1 - 4	Difference temperatures, setting range: 0 to 99 K
min1, 2	Minimal thresholds, setting range: 0 to 150 °C
max1 - 4	Limit of storage temperature, setting range: 0 to 150 °C
F1e - F3e	Switch-on time of time windows 1 to 3
F1a - F3a	Switch-off time of time windows 1 to 3
Uhr	Time (resolution: 10 minutes), setting by the blue keys <i>ab/auf</i> (down/up).
F>A	Assignment menu (which time window interacts with which output) Setting: see chapter „Assignment of the time windows”
Prog	Selection of the program number according to the chosen diagram. The program number defines the basic function of the controller and is the most important input . Setting by the blue keys <i>ab/auf</i> (down/up)
Vorr	Priority menu. Assignment of priority 0 to 4 to the outputs: 0 = no priority, 1 = highest, 4 = lowest priority; setting: see chapter “Assignment of priority”
Vers	Actual software version (important for enquiry calls); it cannot be changed.
Menü	Main menu for access to the sub menus of the controller

Selector switch

diff: The output will be released, when the temperature difference between two set sensors exceeds this value. **diff** is the basic function (differential control) of this unit for most programs. Recommendation: In solar applications, **diff** should be set to 7 - 10K. Somewhat lower values suffice for the feed pump program. The hysteresis has an increasing effect, i.e. reaching the temperature difference plus hysteresis the output will switch on, falling below the difference it will switch off. (ex works = 5,0K)

min: The minimal threshold **min** generally prevents boilers from being clogged with soot. Recommended value in this case: 60 to 70°C. The hysteresis has an increasing effect, i.e. reaching the threshold plus hysteresis the output will switch on, falling below the threshold it will switch off. (ex works = 0°C)

max: The maximum function limits the storage of tanks. The hysteresis has a decreasing effect, i.e. reaching the threshold the output will switch off, falling below the threshold minus hysteresis it will switch on again. (ex works = 90 °C)

Schematic representation of setting values:

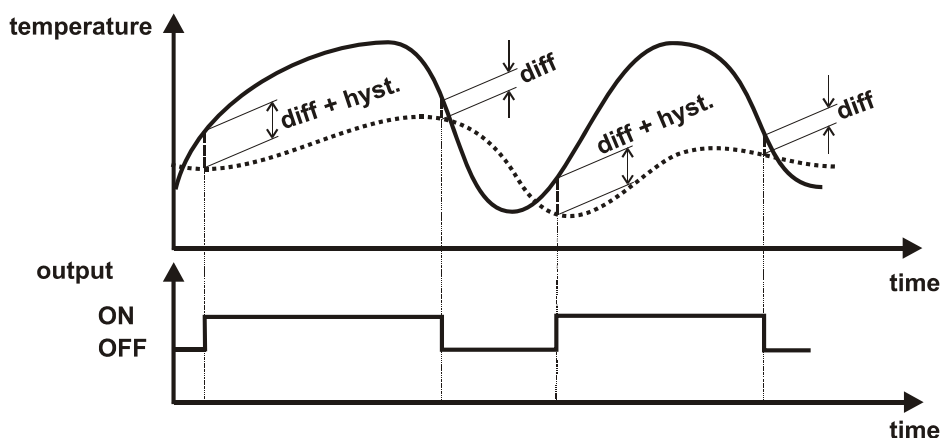
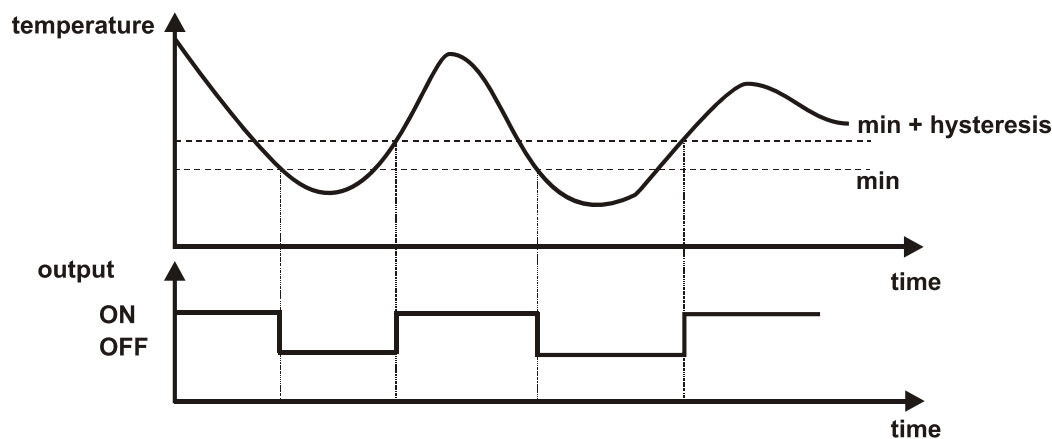
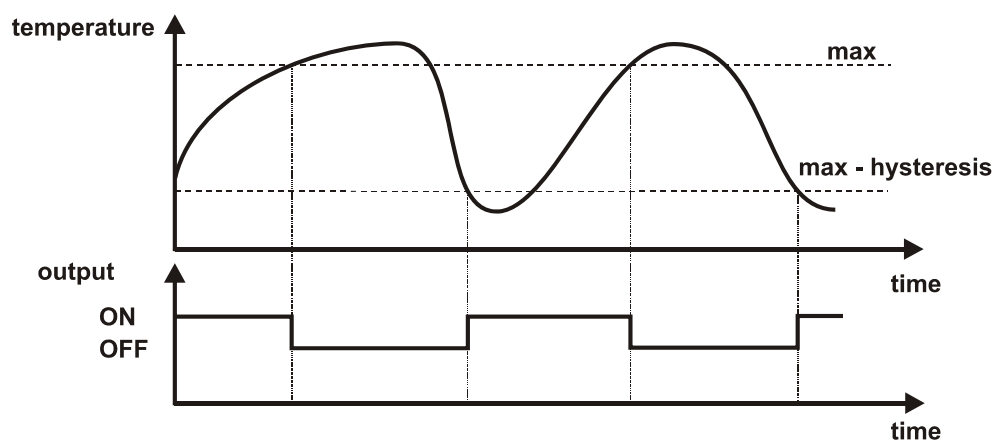

Selector switch

F1e: Switch-on time (e) of first time window (F1). The time window function allows blocking or enabling an output additionally to the conditions of a program. A total of three time windows stands by.

F1a: Switch-off time (a) of first time window (F1).

Uhr: Setting of the actual time, important for correct function of time windows. The controller has a power reserve of approx. 24 hours, i.e. when blackout longer than 24 hours occurs, time must be set again.

F>A: Menu for assignment of each time window to one of the 4 outputs.

Assignment of time windows (F>A)

Position of selector switch: Uhr / F>A



Pressing the yellow „**Eingabe**“ key for 2 seconds causes entry or exit to/from the sub menu



normal (short) pressing switches from one position to the next



The value can be changed with the blue keys **ab/auf** (down/up).

ew

ex works = original setting by the factory



14.5 – actual time = 2:50 pm. Setting by pressing the blue keys **ab/auf**.



Pressing the yellow „**Eingabe**“ key for 2 seconds causes entry to the sub menu **F>A**



F14 – Assignment of time window **1** to output **A4**. In the time window (**F1e – F1a**) the respective program determines the status of the selected output (**A4**). Outside the time window it is switched off.
ew = F10 (time window 1 inactive)



F23 - Assignment of time window **2** to output **A3**. In the time window (**F2e – F2a**) the respective program determines the status of the selected output (**A3**). Outside the time window it is switched off.
ew = F20 (time window 2 inactive)



F30 – Time window **F3e – F3a** is not assigned to an output. Therefore it is inactive.
ew = F30 (time window 3 inactive)



F14 – Pressing the yellow „**Eingabe**“ key at the end of the menu, the run starts again. Going back to normal operation happens by pressing the yellow key „**Eingabe**“ for 2 seconds, turning the selector switch or automatically after one minute.

Selector switch

Program selection (Progr.), assignment of priority (Vorr.)

Position of selector switch: **Prog. / Vorr.**



Pressing the yellow „**Eingabe**“ key for 2 seconds causes entry or exit to/from the sub menu



normal (short) pressing switches from one position to the next



The value can be changed with the blue keys **ab/auf** (down/up).

ew

ex works = original setting by the factory



P16 – Actual used program : 16

Setting by pressing the blue keys **ab/auf**.



Pressing the yellow „**Eingabe**“ key for 2 seconds causes entry to the sub menu **Vorr.** (= priority)



A12 – Assignment of **second** priority to the output **A1**. I.e. the output will be enabled, when all superior outputs with priority 1 are switched off.

ew = A10 (output **A1** switches independently)



A21 – Output **A2** has the highest priority 1.

ew = A20 (output **A2** switches independently)



A31 – Output **A3** has the same (highest) priority 1 as **A2**.

ew = A30 (output **A3** switches independently)



A40 – Output **A4** has assigned no priority. It can switch independently from all other outputs.

ew = A40 (output **A4** switches independently)



A12 – Pressing the yellow „**Eingabe**“ key at the end of the menu, the run starts again. Going back to normal operation happens by pressing the yellow „**Eingabe**“ key for 2 seconds, turning the selector switch or automatically after one minute.

Vers: In this switch position the software version of the computer is displayed (e.g. E5.2). It shows the “intelligence” of the controller and must be advertised to the manufacturer for enquiry calls. It cannot be changed.

Menü: „Menü“ (= menu) allows the setting of about 50 different parameters, which are set ex works to standard settings. Sometimes it is necessary to change them. A change of these values should only be done, if the user has knowledge of all functions as these settings can change the basic features of the controller. Different parameters are stored in sub menus.

Additional functions

Programming procedure („Menü“)

Position of selector switch: Vers. / Menü

Eingabe
 2 Sek.

Pressing the yellow „**Eingabe**“ key for 2 seconds causes entry or exit to/from the sub menu

Eingabe



normal (short) pressing switches from one position to the next

ab auf
 

The value can be changed with the blue keys **ab/auf** (down/up).

ew

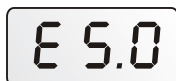
ex works = original setting by the factory

E5.0 – **software version** of controller: It shows the „intelligence“ of the device and cannot be changed.

 2 Sek.

⇒ Pressing the yellow „**Eingabe**“ key for 2 seconds causes entry to the sub menu section



SEn – **sensor type**: Selection of sensor type KTY (=semi-conductor) or Pt1000 (=platinum)

ew = all sensors Pt1000

 2 Sek.

⇒ Entry to sub menu „**sensor type**“



FCo – **function control**: Activating of the detection function (sensor failure, circulation problems). Error messages are displayed, if a failure occurs.

ew = function control deactivated

 2 Sek.

⇒ Entry to sub menu „**function control**“



Utb – **collector excess temperature limit** – switch-off function when too high collector temperature occurs.

ew = collector excess temperature limit function **active**

 2 Sek.

⇒ Entry to sub menu „**collector excess temperature limit**“



StF – **start function**: settings for start-up of pumps in time for solar power systems (ideal for tube collectors)

ew = start function deactivated

 2 Sek.

⇒ Entry to sub menu „**start function**“



Pri – **solar priority**: settings for priority conditions

ew = all values are set to „standard system“

 2 Sek.

⇒ Entry to sub menu „**solar priority**“



PnL – **after-running time**: Settings for each output

ew = no after-running times

Additional functions

● (2 Sek.)

⇒ Entry to sub menu „**after-running time**“

HSt

HSt – hystereses: Setting of the hystereses for exact balancing of the system

ew = all hystereses at 3K per 64°C

● (2 Sek.)

⇒ Entry to sub menu „**hystereses**“

Pd1

Pd1 – pump speed control for output **A1**: Sub menu for the speed processor for activation and alignment of speed control for output A1

ew = pump speed control function deactivated

● (2 Sek.)

⇒ Entry to sub menu „**pump speed control output 1**“

Pd2

Pd2 - pump speed control for output **A2**: Sub menu for the speed processor for activation and alignment of speed control for output A2

ew = pump speed control function deactivated

● (2 Sek.)

⇒ Entry to sub menu „**pump speed control output 2**“

Hau

Hau – auxiliary output A5: Linking of the auxiliary output **A5** to the outputs A1 – A4 and the time windows F1 – f3

ew = AUS (=off) (auxiliary output switched off)

● (2 Sek.)

⇒ Entry to sub menu „**auxiliary output A5**“

End

End – end of the passage: the passage can be repeated. Exit from each display to normal operation happens by pressing the yellow „**Eingabe**“ key for 2 seconds, turning the selector switch or automatically after one minute.

SEn Sensor type

Solar collectors reach standstill temperatures of 200 to 300°C. No value above 200°C is expected due to the sensor installation point and physical properties (dry steam does not conduct heat well, for instance). The standard Pt1000 series sensors can be permanently exposed to 250°C and briefly to 300°C. KTY10 sensors are designed for brief use at 200°C. The **Sensor type** menu enables changing over of the individual sensor inputs between Pt1000 and KTY types.

As default factory setting all inputs are set to Pt1000 type.

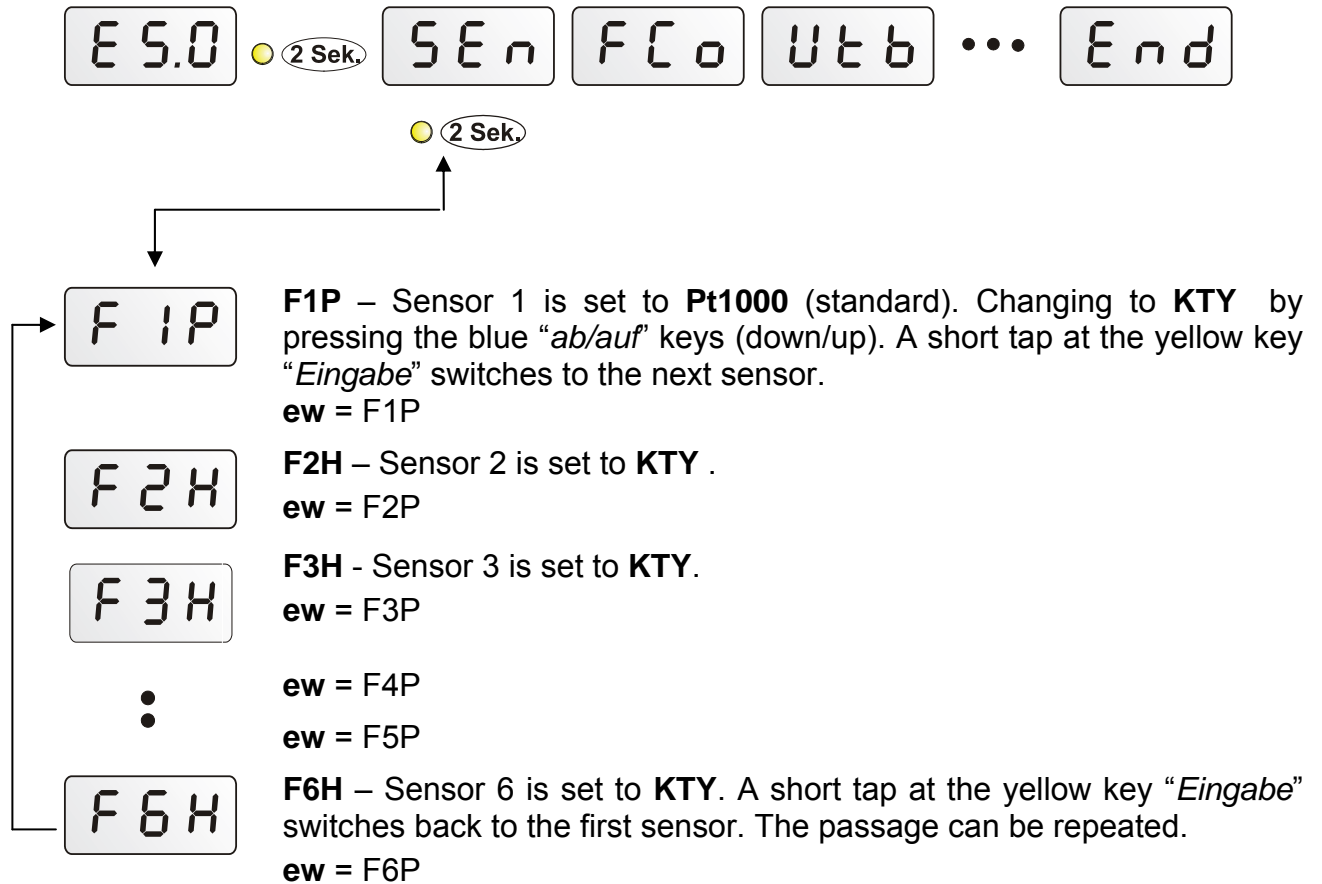

The radiation sensor **GBS** can be connected to each sensor input (sensor type **KTY**) and assigned to the start or the priority function.

Additional functions

F C 0 Function control

Function control allows detection of sensor interruption or short circuit (error code **FF1** – **FF6**), missing circulation caused by too high temperatures (>40K) between solar panel and consumer after 10 minutes pump-run (error code **FF7**) and circulation error (error code **FF8**) of the solar power system.

For detection of circulation error a temperature sensor gets a threshold temperature. Circulation error applies, if the sensor exceeds the set threshold temperature between 00:00 to 5:00 am.

If an error occurs the display shows alternating to the usual display an error code in one-second-intervals.

FF1..... FF6.....Short circuit or interruption T1 to T6

FF7..... Temperature difference between solar collector and tank is more than 40K after 10 minutes pump run. Probably no circulation!

FF8..... Circulation error. The sensor selected under **Fc** has exceeded the temperature threshold **L** in the period 00:00 to 05:00 am.



2 Sek.

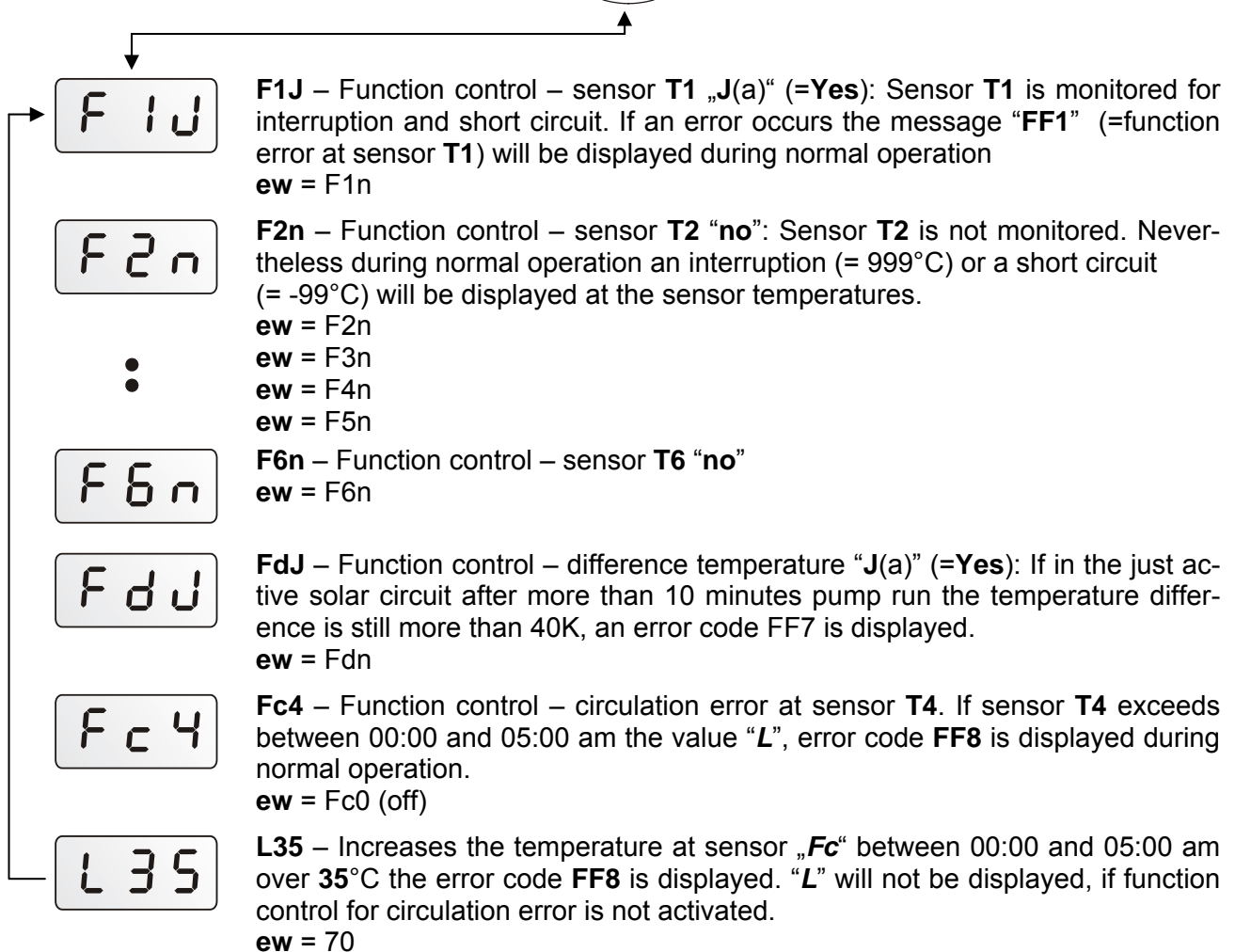

U t b

Collector excess temperature limit

Steam builds up when the system is not circulating. When it automatically switches on again, the pump does not have the pressure to lift the fluid level above the highest point in the system (collector feed line). If there is no circulation, the load on the pump is enormous. This function allows the pump to be blocked above a set collector temperature threshold until a second set threshold is fallen short of.

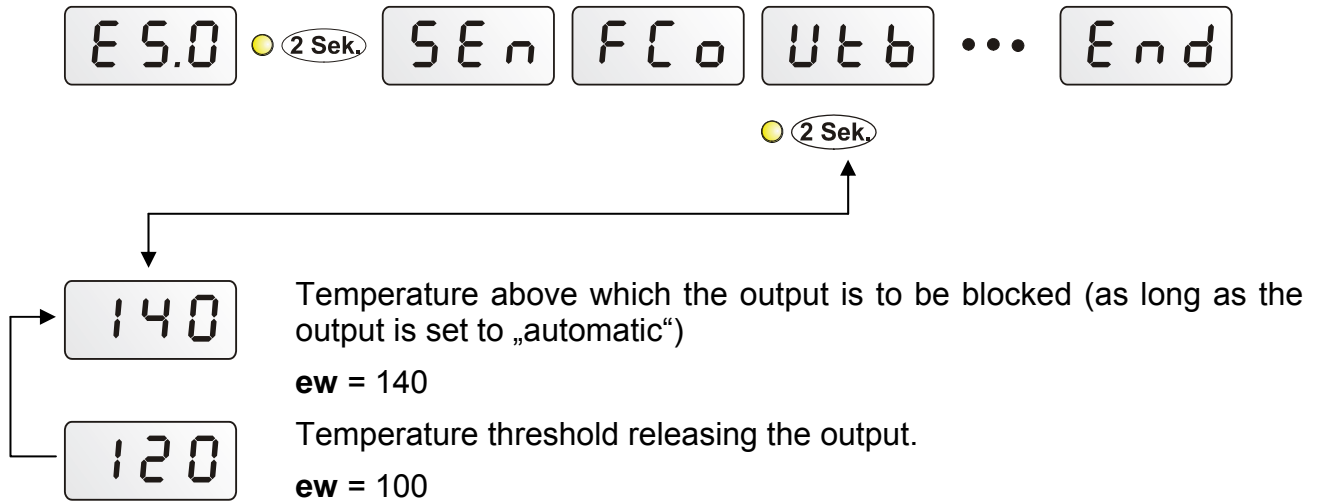

The higher temperature is the switch-off temperature; the lower is the temperature, at which the solar pump will be switched on again.

Switch-off temperature can be set up to 199°C. Setting over this value „AUS“ is displayed (=off). That means that the function is deactivated.

Additional functions

5 t F

Start function (ideal for tube collectors)

In the morning, solar power systems sometimes do not “start” quickly enough because the warm heat transfer medium does not reach the collector sensor. Flat collector panels and **forced-circulation vacuum tubes** generally lack sufficient gravitational force.

The start function tries to release a rising interval while the collector temperature is constantly monitored. The computer first determines the weather conditions based on the constant measurements of the collector temperatures. It thus determines the right time for a short rinsing interval to maintain the actual temperature for normal operation.

When the radiation sensor is used, the solar radiation is used for the calculation of the start function (radiation sensor **GBS 01** - non-standard accessory).

The start function is deactivated ex works.



A 1

A 1 – Activation of start function. **A 1** means start function active, **A 0** = start function deactivated
ew = A 0

F 3

F 3 – Connection of a radiation sensor to sensor input **T3**. **F 0** means, that the average temperature (long-term mean regardless of the weather) is calculated instead of the radiation sensor value.
ew = F 0

c 20

c20 – radiation threshold 200W/m², above which rinsing is allowed. Without a radiation sensor, the computer calculates the necessary temperature increase for the long-term mean that launches rinsing from this value.
ew = 15

r 15

r15 – Pump runtime (rinsing time) in seconds. During this time, the pump should have pumped roughly half of the content of the collector’s heat transfer medium past the collector sensor.
ew = 15

i 35

i35 – Maximum allowable interval between two rinses in minutes (example: 35 minutes). This time is automatically reduced according to the temperature increase after rinsing.
ew = 20

n 4

n 4 – Number of start attempts (= counter). The system is automatically reset for a start attempt if the last start attempt was more than four hours ago.



Priority menu

When the consumers with lower priority are being filled, the unit monitors the irradiation at the radiation sensor or the collector temperature. If a radiation threshold C is reached or the collector temperature is exceeded by a value calculated from the threshold for the low-priority consumer, the priority timer is activated. The pump then switches off for a set waiting time of 60 sec (waiting time 1)

After the rinsing time (1, 3), the computer calculates the increase in collector temperature. It detects whether the set waiting time tA has been reached to heat the collector to the priority temperature. In the second case, the unit waits until the priority has been reached to switch. If the computer detects that the increase will not suffice within the tA time (4, 5), it discontinues the process and reactivates the time again after tL. **At tL=0, the low-priority is only allowed when the maximum threshold for the priority is reached (=absolute priority).**

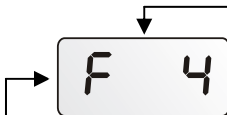
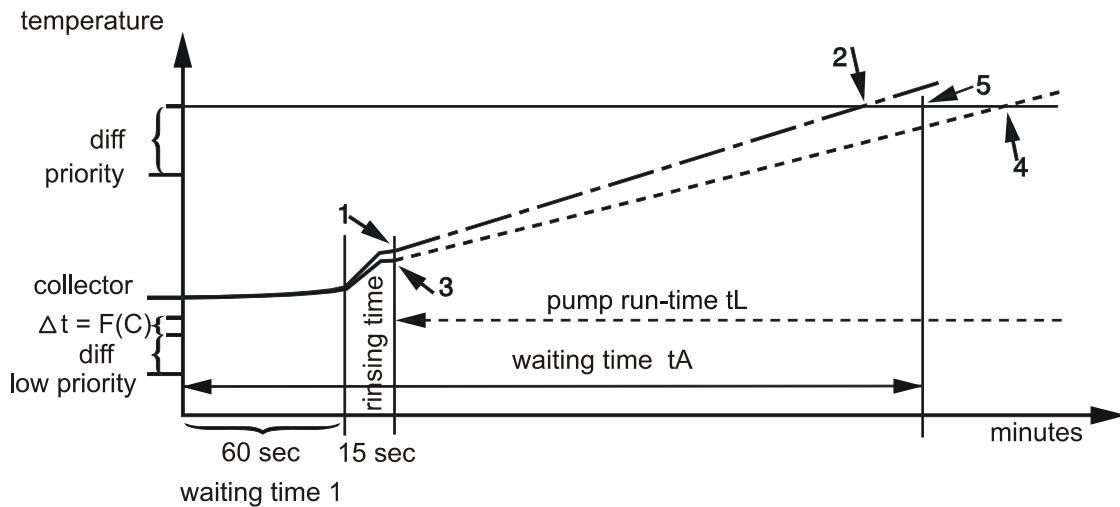

F 4 – Sensor **T4** is a **radiation sensor** starting the priority timer. If the radiation sensor exceeds the radiation threshold “c”, the priority timer is launched. Without the radiation sensor, the launch is based on the collector temperature. Setting range: F0 (= no radiation sensor) to F4
ew = F 0



c20 – **radiation threshold** in W/m² (e.g. 200 W/m²) above which rinsing is allowed. Without a radiation sensor (**F 0**), the computer calculates the necessary temperature increase for the long-term mean that launches rinsing from this value. Setting range: c 0 to 99
ew = 30



tA5 – **Waiting time of low priority** (5 minutes). This is the time in which the collector should reach the temperature necessary for priority operation. Setting range: 0 to 9 minutes (tA0 to tA9)
ew = 5



tL3 – **Pump run-time** of low-priority (e.g. 30 minutes). If the solar radiation to switch to priority is not sufficient, the low priority is allowed again for this time. Setting range: 0 to 90 minutes (tL0 to tL9) in increments of 10 minutes, ew = 2

Additional functions

PnL After-running time

During the start phase, the pumps may repeatedly switch on and off for a long time, especially with solar and heating systems with long hydraulic system lines. This response can be reduced by using a speed control or increasing the pump after-run time. After access of the sub menu **PnL** the display for the after-running time for output 1 is visible:

(Setting range: 10 sec to 9 min; 0 = no after-running time)

E.g.: **t1.3** - after-running time of output 1 is 30 seconds.

E.g.: **t13** - after-running time of output 1 is 3 minutes.

A short tap at the yellow key "**Eingabe**" switches to the after-running time of output 2. Setting ex works for all outputs is 0 (t10, t20, t30, t40).

HSt Hystereses

Hysteresis means the difference between switch-on and switch-off temperature. I.e. a thermostat with hysteresis 10K, which is set to 70°C, switches off at 70°C and switches on again at 60°C. Hystereses in UVR 64 are not constant, but they change according to the temperature and can be set from 1 to 9 K per 64°C.

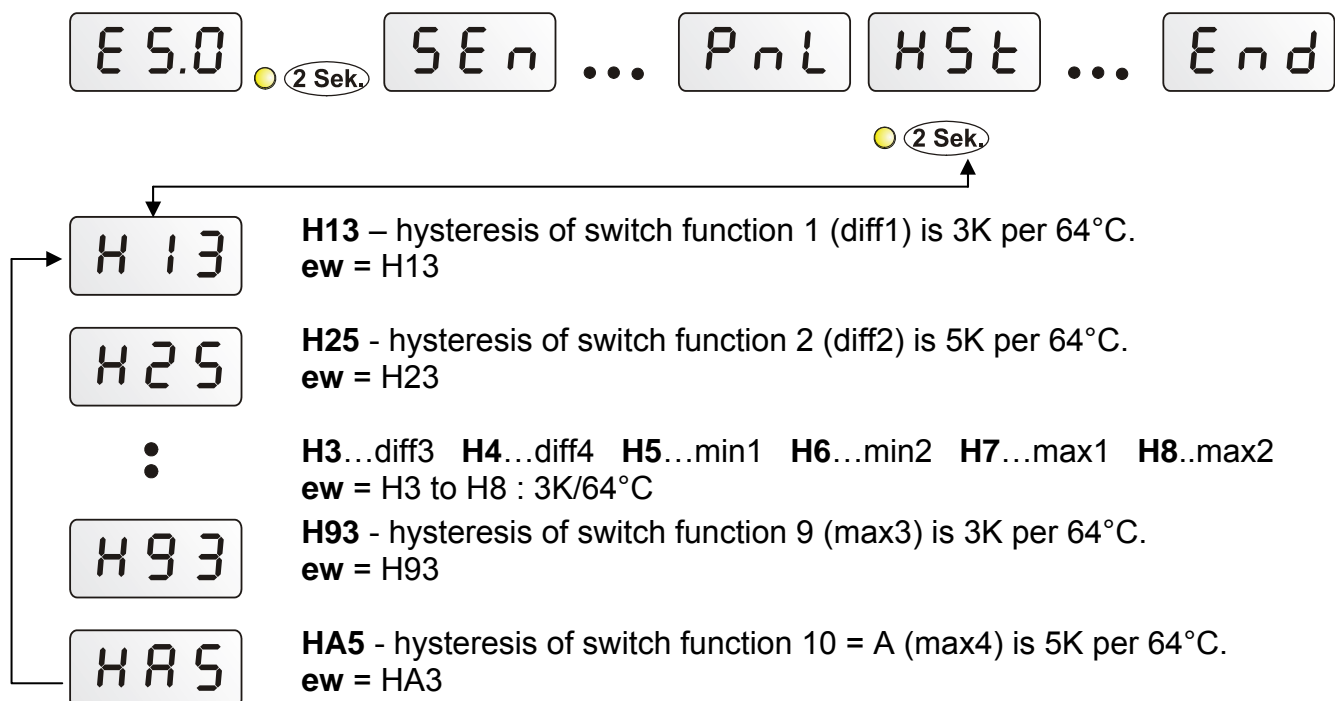

The advantage of hystereses change according to the temperature is, that different consumers resp. tanks can be used with same settings. Thus a swimming pool with maximum temperature of 30°C gets a lower hysteresis than a buffer with maximum temperature of 90°C.

Example: Maximum for pool is set to 30°C, hysteresis = 3K/64°C (=ex works).

The hysteresis at 30°C results to approximately the half – therefore ca. 1.5K. Feed is blocked at 30°C and is enabled at approx. 28.5°C.

Hystereses of difference values diff 1 to 4 refer to the colder sensor. E.g. if the colder sensor has 64°C, the output will be switched on exceeding the difference **diff** + hysteresis 3K and switched off falling below the difference **diff**.

Pd1

Pd2

Pump speed control

The pump speed control can be used to change the delivered quantity - i.e. the volume flow - of usual commercial circulating pumps in 30 steps. This provides constant levels of (differential) temperatures in the system.

Setting of optional sensors and temperatures is possible. The pump speed control is – if activated – allowed, when the normal difference- and/or thermostat function enables the output, i.e. it is like a device, which is connected after the normal controller.

This simple solar diagram will now be used to show the possibilities of this process:

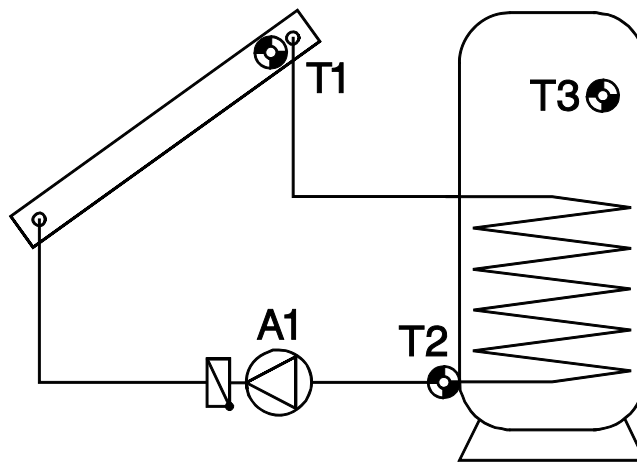

◆ **Absolute value control A** = maintaining a sensor

T1 can be kept at one temperature (such as 60°C) very well by using the speed control. If the solar radiation is reduced, **T1** becomes colder. The control unit then lowers the speed and hence the flow rate. However, that causes the warm-up time of the heat transfer medium in the collector to increase, thus increasing **T1** again.

A constant return (**T2**) may make sense as an alternative in various systems (such as boiler feeds). **Inverse** control characteristics are necessary for this (identified by a minus). If **T2** increases, the heat exchanger does not provide enough energy to the tank. The flow rate will then be reduced. The longer dwell time in the exchanger cools the heat transfer medium more, thus reducing **T2**.

It does not make sense to keep **T3** constant as the variation in the flow rate does not directly affect **T3**; hence, no regulator circuit will result.

Additional functions

◆ **Differential control F** = keeps the temperature constant between two sensors.

Keeping the temperature difference constant between **T1** and **T2**, for instance, allows for “shifting” operation of the collector. If **T1** drops due to lower irradiation, the difference between **T1** and **T2** thus drops. The control unit then lowers the speed, which increases the dwell time of the medium in the collector and hence the difference between **T1** and **T2**.

An inversely written **F** means an inverse speed characteristic, i.e. the speed increases with falling difference.

Note: This difference “**d**” always has to be greater than the switch-off difference **diff** of the basic function. If „**d**“ is lower, the basic function of pump release blocks before the speed control has reached the desired value.

◆ **Limiter function L** = If a set temperature event occurs, the speed control starts, thus keeping a sensor constant.

If, for instance, **T3** reaches 55°C (activation threshold), the collector should be kept at a certain temperature. Maintaining a sensor then works as with absolute value control. An inversely written **L** means an inverse speed characteristic, i.e. the speed increases with falling temperature.

The three described methods can be activated all together. If the absolute value control (maintaining a sensor) and the differential control (maintaining the difference between two sensors) are both active, the slower of the two speeds “wins out”. The limiter function “overwrites” the speed results from other control methods. A set limit can thus block the control of absolute values or differences.

In the example, keeping the collector temperature at 60°C with the absolute value control is blocked when the tank has already reached 55°C at the top = the fast provision of hot water is complete and is now to be continued with full volume flow (and hence a lower temperature but slightly better efficiency). To do so, a value that value automatically requires full speed (such as S1 = 10°C) has to be entered as the new desired temperature in the event control.

Waveform

Wave packets - only for circulating pumps with standard motor dimensions. Here, individual half cycles are bled in to the pump motor. The pump runs on pulses and only produces a smooth flow of the heat transfer medium when the rotor’s moment of inertia has been overcome.

Benefit: Great dynamics of 1:10, well suited for usual commercial pumps without internal electronics and a motor length of around 8 cm.

Drawback: Linearity depends on the pressure loss; there is some noise, not suitable for pumps with evidently deviating motor diameters and / or length from 8 cm.

Pump standstill

The wave packet method (standard) allows for variations in the volume flow by a factor of 10 in 30 increments. If the flow rate is too low, flap valves may cause a system standstill. In addition, low power stages at low speeds may cause the rotors to stop. Such a standstill may sometimes be desired, which is why stage 0 is allowed as the lowest stage.

The best speed limit is found in a simple test. Use the command “*u*” to set a speed for testing. When setting the parameter “*u*”, the pump runs with the desired speed for system control. Remove the rotor lid to see the rotor. Then lower the speed until the rotor stops. Set the limit three increments above this point to ensure safe pumping.

Stability problems

The speed control has a PID controller. It ensures an exact and fast adjustment of the actual value to the set point. **In applications such as solar power systems or feed pumps, the following parameters should be left in factory settings.** With a few exceptions, the system will run stably. These two values have to be balanced, however, especially for hygienic hot water from the external heat exchanger. In addition, in this case the use of an ultra-fast sensor (non-standard accessory) is recommended at the hot water outlet.

The parameters *Pr*, *In*, and *di* can also be determined in a test: Assume that the pump is running in automatic mode in a unit that is ready for operation with appropriate temperatures. With *In* and *di* set to zero (= switched off), *Pr* is reduced every 30 seconds starting at 9 until the system is instable. In other words, the pump speed changes rhythmically and can be read in the menu “*n*” (=actual speed). The proportional part that becomes instable is noted as P_{krit} just as the duration of the oscillation (= time between the two highest speeds) is noted as t_{krit} . The following formulas can be used to determine the correct parameters.

$$Pr = 1,6 \times Pr_{krit} \qquad In = \frac{t_{krit} \times Pr}{20} \qquad di = \frac{Pr \times 8}{t_{krit}}$$

A typical result of hygienic service water with the ultrafast sensor is *Pr* = 8, *In* = 9, *di* = 3.

For reasons not entirely understood, the setting *Pr* = 3, *In* = 1, *di* = 4 has proven practical. Probably, the control unit is so unstable that it oscillates very quickly and appears to be balanced due to the system’s and the fluid’s inertia.

Additional functions

Pump speed processor

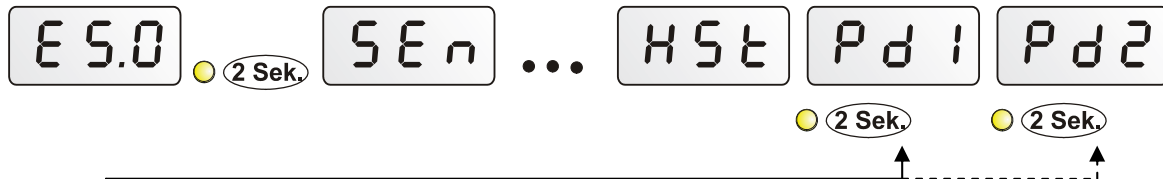

A 2

A 2 – absolute value control: Sensor **T2** being kept constant by pump speed. The speed increases as temperature **T2** does.

A-2 means that speed increases as temperature **T2** drops (= inverse mode)

ew = A 0 (switched off)

c 60

c60 – desired value for absolute value control: When “**A**” is activated, the controller tries to keep constant the sensor „**A**“ at the value „**c**“ (e.g. 60°C).

ew = 50

F 13

F13 – differential control: Keeping the temperature difference constant between **T1** and **T3**. **T1** is the warmer sensor. Speed increases, if difference between **T1** and **T3** does. Inverse **F** means inverse mode.

ew = F 0 (switched off)

d 5.8

d5.8 – desired value for differential control. When “**F**” is activated, the controller tries to maintain the difference between the two sensors under “**F**” at the value „**d**“ (e.g. 5.8K).

ew = 10

L 31

L31 – limiter function: If the sensor **T3** increases the set limit „**b**“, the controller tries to maintain the sensor **T1** at the maximum value „**h**“.

ew = L 0 (switched off)

b 75

b75 – limiter value: If sensor „**L**“ (e.g. **T3**) exceeds the maximum „**b**“ (e.g. 75°C), the controller tries to maintain the second sensor (e.g. **T1**) at the temperature „**h**“.

WE = 60

h 85

h85 – maximum value: After occurring the event “**b**” the second sensor (e.g. **T1**) will be kept constant at the maximum value (e.g. 85°C). “**h**” are temperatures below 100°C, but “**H**” is more than 100°C.

ew = H30 (=130°C)

P r 8

Pr8 – proportional part (amplification of controlling): The speed is changed by one increment for each 0.8K of deviation from the desired value. A large number leads to a more stable system but also to more deviation from the predefined temperature. **ew** = 5

I n 4

In4 – integral part: For each 1K of deviation from the desired value, the speed changes one increment every 4 seconds. A large number provides a more stable system, but it then takes longer to reach the desired value. **In0** = no integral part, **ew** = 5

d 15

di5 – Differential part: The faster a deviation occurs between the desired and the current value, the greater the short-term overreaction will be to provide the fastest compensation possible. If the desired value deviates at a rate of 0.5K per second, the speed is changed by one increment. Large numbers provide a more stable system, but it then takes longer to reach the desired value. Optimal values depend on the system and have to be checked experimentally.

di0 = no differential part, **ew** = 5

Additional functions



u6 – Lower speed limit: Limiting the speed for avoiding a rotor standstill. The controller varies the speed between step 30 and down to “u” (e.g. 6)

ew = 1

n18 – actual speed stage: if speed control is activated, „n 2“ shows the actual speed stage. At “n 0” the pump stands, at “n 1” it has the slowest speed and at “n30” full speed. This value is a check value and not changeable.

The passage starts again with absolute value control. Going back to normal operation happens by pressing the yellow key for 2 seconds, turning the selector switch or automatically after one minute.

Additional functions



Auxiliary output A5

The auxiliary output can be linked via “**AND**” (\cup) (German: und) resp. “**OR**” (\square) conditions with the outputs 1 to 4 or/and the time windows 1 to 3.

Inverse mode is possible ($\bar{\cup}$, $\bar{\square}$): Auxiliary output is linked with the switched off output resp. the not fulfilled time window.

The auxiliary output is switched on, if **at least** one of the outputs (time windows) identified by “ \square ” is switched on **or at least one** of the outputs (time windows) identified by “ $\bar{\square}$ ” is switched off **and all** of the outputs (time windows) identified by “ \cup ” are switched on **and all** of the outputs (time windows) identified by “ $\bar{\cup}$ ” are switched **off**.

Note: The condition „**AND**“ is only possible in combination with at least one condition „**OR**“ . To achieve an “**AND**” condition it is necessary to define at least one output with “ \square ” or “ $\bar{\square}$ ” .

Schematic representation of operating mode:

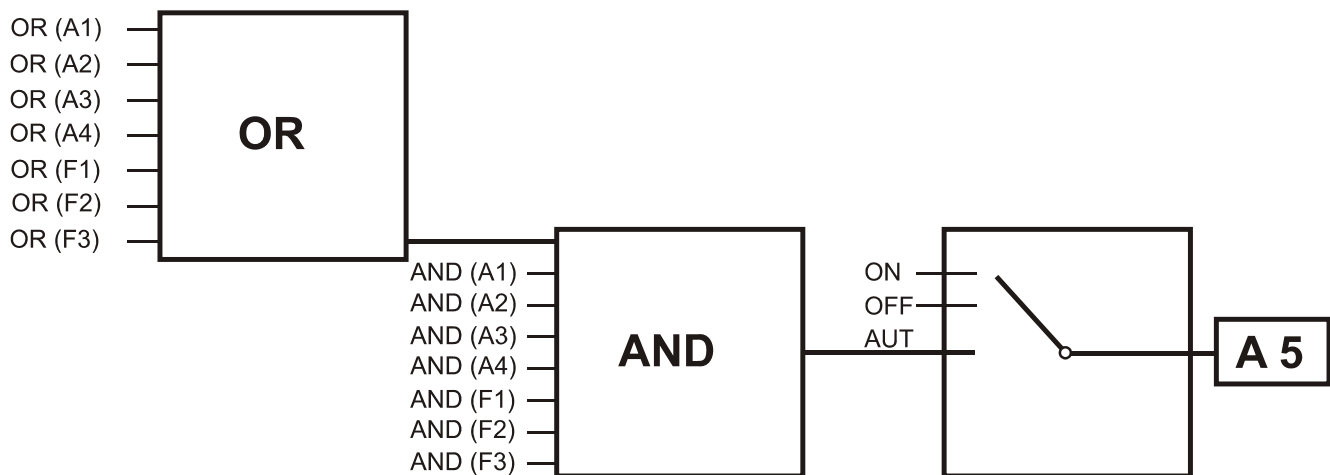

The terminals of the auxiliary output 5 are potential free.

Example: (using all linking symbols):

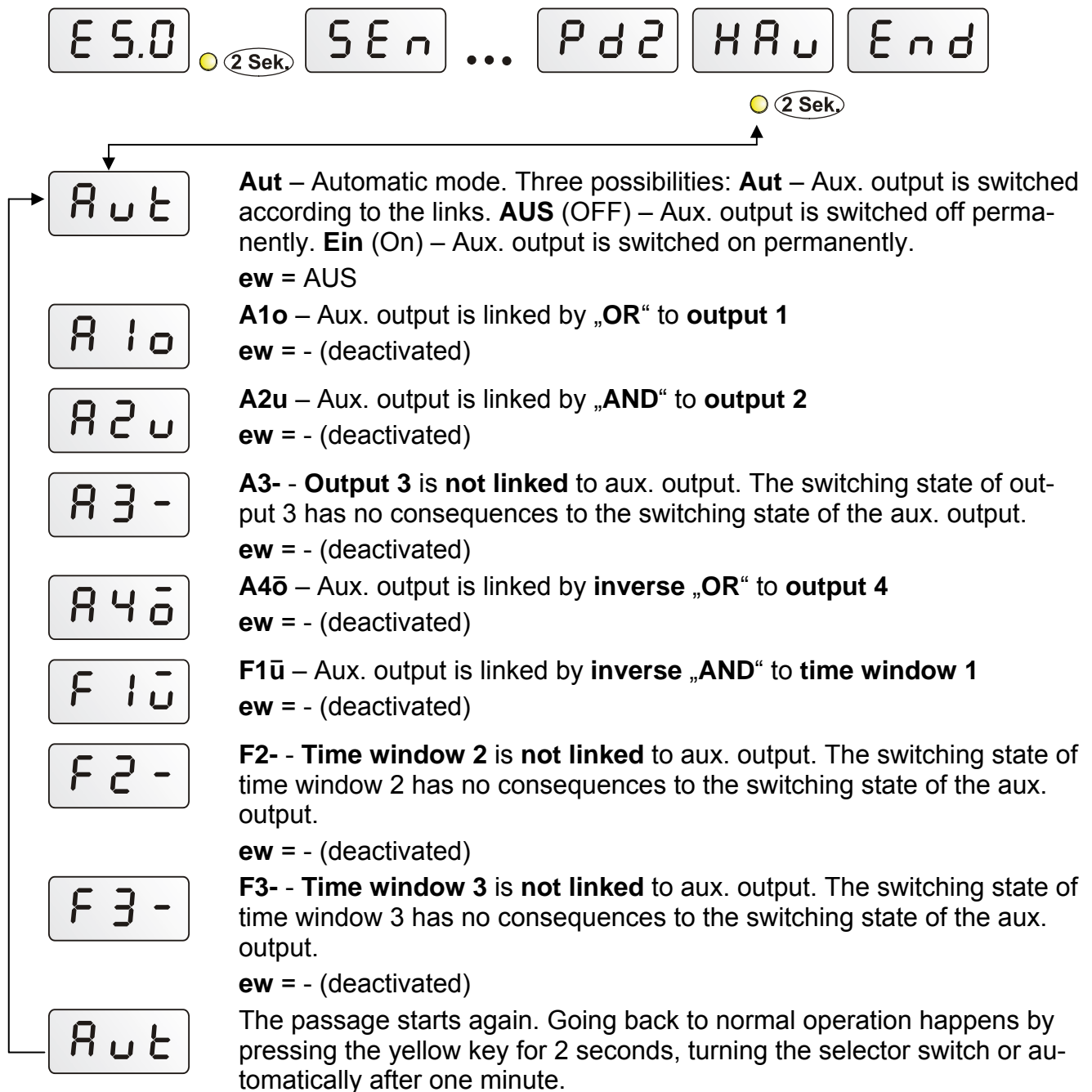

In this example the auxiliary output switches on if:

- ◆ output 1 is switched on **or** output 4 is switched off **and**
- ◆ output 2 is switched on **and**
- ◆ time window 1 is switched off.

Instructions for troubleshooting:

In general, all of the settings in the menus and the terminals should be checked if there is an error.

Malfunction, but “realistic” temperatures:

- ◆ Check the program number.
- ◆ Check the thresholds for on/off (min/max) and the set differential temperatures (diff). Have the thermostat and differential thresholds been (resp. not been) reached?
- ◆ Are time windows linked to outputs?
- ◆ Which priority is defined?
- ◆ What is changed in the sub menus?
- ◆ Can the output be switched on/off in manual mode? - If endurance runs and standstill at the output produce an appropriate reaction, the unit is definitely not broken.
- ◆ Are all of the sensors connected to the right terminals? - Heat the sensor using a lighter and check the display.

Incorrect temperature displayed:

- ◆ If a value such as -999 is displayed when a sensor short-circuits or 999 if there is an interruption, the cause may not be a material or terminal error. Are the correct sensor types (KTY or Pt1000) selected under the menu **SEn**? The factory settings have all inputs set to **P** (Pt1000).
- ◆ The sensor can also be checked without a measuring device simply by changing the part that is probably defective with one that works at the strip terminal and checking the display. The resistance measured with an ohmmeter should have the following value according to the temperature:

Temp. [°C]	0	10	20	25	30	40	50	60	70	80	90	100
R (Pt1000) [Ω]	1000	1039	1078	1097	1117	1155	1194	1232	1271	1309	1347	1385
R (KTY) [Ω]	1630	1772	1922	2000	2080	2245	2417	2597	2785	2980	3182	3392

If the unit does not run when it has power, the quick-blow fuse 3.15A that protects the control system and the output should be checked and exchanged if necessary.

The **settings of the menu functions ex works** can be **restored** at any time using the yellow key „**Eingabe**“ when plugging the unit in.

As the programs are constantly being revised and improved, there may be a difference in the numbering of the sensors, pumps, and programs. Only the instruction manual provided with the device delivered applies (identical version number). The version number of the manual must correspond to the one for the device.

If the control system malfunctions despite these checks as described above, please contact your retailer or the manufacturer directly. The cause of the error can only be determined if the **table of settings has been completely filled** in along with a description of the error. If possible, also include a hydraulic diagram of the system.

Table of settings:

If the control system fails unexpectedly, all of the settings should be reset for initial configuration. In this case, problems are inevitable if all of the setting values are entered in the following table. **If there are questions, this table has to be provided.** Only then is a simulation possible to reproduce the error.

ew = factory setting (ex works)

cs = controller settings

	ew	cs		ew	cs
Values					
Sensor T1		°C	Output A1	Aut	
Sensor T2		°C	Output A2	Aut	
Sensor T3		°C	Output A3	Aut	
Sensor T4		°C	Output A4	Aut	
Sensor T5		°C			
Sensor T6		°C			
Program Prog.	0		Version		

Basic parameters PAR					
diff1	5 K	K	Hysteresis H1	3K/64°C	K/64°C
diff2	5 K	K	Hysteresis H2	3K/64°C	K/64°C
diff3	5 K	K	Hysteresis H3	3K/64°C	K/64°C
diff4	5 K	K	Hysteresis H4	3K/64°C	K/64°C
min1	0 °C	°C	Hysteresis H5	3K/64°C	K/64°C
min2	0 °C	°C	Hysteresis H6	3K/64°C	K/64°C
max1	90 °C	°C	Hysteresis H7	3K/64°C	K/64°C
max2	90 °C	°C	Hysteresis H8	3K/64°C	K/64°C
max3	90 °C	°C	Hysteresis H9	3K/64°C	K/64°C
max4	90 °C	°C	Hysteresis HA	3K/64°C	K/64°C

Time window F					
Time window F1 on	7:00		Time window F1 off	8:00	
Time window F2 on	11:00		Time window F2 off	13:00	
Time window F3 on	18:00		Time window F3 off	20:00	
Time window F1 > output	10				
Time window F2 > output	20				
Time window F3 > output	30				

Priority assignment Vorr.					
Output A1	10		Output A2	20	
Output A3	30		Output A4	40	

Sensor type SEn					
Sensor T1	F1P		Sensor T2	F2P	
Sensor T3	F3P		Sensor T4	F4P	
Sensor T5	F5P		Sensor T6	F6P	

	ew	cs		ew	cs
Function control <i>FCo</i>					
Sensor T1	F1n		Difference temperature	Fdn	
Sensor T2	F2n		Circulation error	Fc0	
Sensor T3	F3n		Value L	L70	°C
Sensor T4	F4n				
Sensor T5	F5n				
Sensor T6	F6n				

Collector excess temperature <i>Utb</i>			Start function <i>StF</i>		
Switch-off temperature	140°C	°C	Start function active	A 0	
Switch-on temperature	100°C	°C	Connection radiation sensor	F 0	
			Radiation threshold	c15	W/m ²
			Pump run time	r15	s
			Interval time	i20	min
			Number of start attempts	n 0	

Priority menu <i>Pri</i>			After-running time <i>PnL</i>		
Connection radiation sensor	F 0		Output 1	t10	min
Radiation threshold	c30	W/m ²	Output 2	t20	min
Waiting time	tA5	min	Output 3	t30	min
Pump run time	tL2	min	Output 4	t40	min

Speed control					
Speed control 1 <i>Pd1</i>			Speed control 2 <i>Pd2</i>		
Absolute value control	A 0		Absolute value control	A 0	
Desired value for A	c50	°C	Desired value for A	c50	°C
Differential control	F 0		Differential control	F 0	
Desired value for F	d10	K	Desired value for F	d10	K
Limiter function	L 0		Limiter function	L 0	
Limit for L	b60	°C	Limit for L	b60	°C
Maximum value for L	H30	°C	Maximum value for L	H30	°C
Proportional part	Pr5		Proportional part	Pr5	
Integral part	In5		Integral part	In5	
Differential part	di5		Differential part	di5	
Minimum speed	U 1		Minimum speed	U 1	

Auxiliary output <i>HAu</i>					
Automatic/ON/OFF	AUS				
Output A1	A1-		Time window F1	F1-	
Output A2	A2-		Time window F2	F2-	
Output A3	A3-		Time window F3	F3-	
Output A4	A4-				

Technical data:

Power supply:	230V +/-10%, 50- 60Hz,
Power input:	max. 3 VA
Fuse:	3.15 a fast acting (device & output)
Supply cable:	3x 1mm ² H05VV-F conforming to EN 60730-1
Protection class:	IP40
Allowed ambient temperature:	0 to 45°C
Sensors:	Pt1000, accuracy between 0 and 1000°C: +/-0.35K
Tank sensor BFPT1000:	Diameter 6 mm, according to immersion sleeves, incl. 2 m cable (up to 90°C continuous load)
Collector sensor KFPT1000:	Diameter 6 mm, according to immersion sleeves, incl. 2 m cable (up to 180°C) with connection box and overvoltage protection
Difference temp.:	adjustable from 0 to 99°C (diff)
Thresholds:	adjustable from 0 to 150°C (min, max)
Hysteresis:	adjustable from 1 to 9°C per 64°C
Speed control:	30 speed stages result in change of amount of max. 1:10 . Possible speed control modes: absolute value, difference and absolute value at occurrence of an event.
Temperature display:	from -50 to +199°C
Resolution:	from -9.9 to 100°C with 0.1°C, otherwise 1°C
Accuracy:	typ. 0.4 and max. +/-1°C in range 0 to 100°C
Outputs:	Triac output 1 and output 2 (minimum load of 20W required) Relay contacts outputs 3, 4 and aux. output 5
Rated current load A1, A2:	250V / 1.5 A,
Rated current load A3, A4, A5:	250V / 2.5A
Quantity delivered:	Controller with 6 temperature sensors (5 x BFPT1000, 1 x KFPT1000), 4 immersion sleeves TH 140 mm, mounting material, mains cable with plug



TECHNISCHE ALTERNATIVE

ELEKTRONISCHE STEUERUNGSGERÄTEGESELLSCHAFT M. B. H.
A-3872 Amaliendorf, Langestraße 124

EC- DECLARATION OF CONFORMITY

Document- Nr. / Date TA10010 / 03.09.2010
Company / Manufacturer: Technische Alternative
elektronische SteuerungsgerätegesmbH.
Address: A- 3872 Amaliendorf, Langestraße 124
Product: UVR 64
The stated above product complies with the following essential requirements:
EU requirements: 2006/95/EG Low voltage standard
2004/108/EG Electromagnetic compatibility

Employed standards:

EN 60730-1:2009 08 01 Automatic electrical controls for household and similar use -
Part 1: General requirements
EN 61000-6-3:2007 11 01 Electromagnetic compatibility (EMC) - Part 6-3: Generic
standards - Emission standard for residential, commercial
and light-industrial environments
EN 61000-6-2:2006 05 01 Electromagnetic compatibility (EMC) - Part 6-2: Generic
standards - Immunity for industrial environments
Position of CE - label: On packaging, manual and type label



Issuer: Technische Alternative
elektronische SteuerungsgerätegesmbH.
A- 3872 Amaliendorf, Langestraße 124

This declaration is submitted by:

General management

This declaration certifies the agreement with the named standards, contains however
no warranty of characteristics.
The security advices of included product documents are to be considered.

UIDNr.: ATU 17986204, Firmenbuch-Nr.: FN37578m, DVR-Nr.:1011553, ARA-Lizenz-Nr.:1996

Telefon ++43(0)2862/53635 Fax ++43(0)2862/53635-7 E-mail: mail@ta.co.at <http://www.ta.co.at>

Guarantee conditions

Note: The following guarantee conditions do not in any way limit the legal right to a guarantee, rather expand your rights as a consumer.

1. The company Technische Alternative elektronische Steuerungsgerätegesellschaft m. b. H. provides a two-year guarantee from the date of purchase by the end consumer for all the devices and parts which it sells. Defects must be reported immediately upon detection and within the guarantee period. Technical support knows the correct solution for nearly all problems. In this respect, contacting us immediately will help to avoid unnecessary expense or effort in troubleshooting.
2. The guarantee includes the free of charge repair (but not the cost of on site fault-finding, removal, refitting and shipping) of operational and material defects which impair operation. In the event that a repair is not, for reasons of cost, worthwhile according to the assessment of Technische Alternative, the goods will be replaced.
3. Not included is damage resulting from the effects of overvoltage's or abnormal ambient conditions. Likewise, no guarantee liability can be accepted if the device defect is due to: transport damage for which we are not responsible, incorrect installation and assembly, incorrect use, non-observance of operating and installation instructions or incorrect maintenance.
4. The guarantee claim will expire if repairs or actions are carried out by persons who are not authorized to do so or have not been so authorized by us or if our devices are operated with spare, supplementary or accessory parts which are not considered to be original parts.
5. The defective parts must be sent to our factory with an enclosed copy of the proof of purchase and a precise description of the defect. A filled in "service advice note", which can be downloaded from our homepage www.ta.co.at, will accelerate processing. A prior clarification of the defect with our technical support is necessary.
6. Services provided under guarantee result neither in an extension of the guarantee period nor in a resetting of the guarantee period. The guarantee period for fitted parts ends with the guarantee period of the whole device.
7. Extended or other claims, especially those for compensation for damage other than to the device itself are, insofar as a liability is not legally required, excluded.

TECHNISCHE ALTERNATIVE

elektronische Steuerungsgerätegesellschaft m. b. H.

A-3872 Amaliendorf Langestraße 124

Tel ++43 (0)2862 53635

Fax ++43 (0)2862 53635 7

E-Mail: mail@ta.co.at

--- www.ta.co.at ---



© 2011