



Supplementary manual

UVR16x2E-DE/NP

Triac versions

Table of contents

General information	1
UVR16x2E-DE.....	2
UVR16x2E-NP.....	3
Processor module	3
UVR16x2-E terminal diagram	4
Schematic diagram of programming strips, switching outputs and mains connection	5
Terminal markings of switching outputs	5
Current sensors 1-2, programming strips 3 and 6, AC/DC converter input 4, STB connection 5.....	6
Ribbon cable 7, mains connection 8-10, jumper 11 and fuse 12 for outputs 12-14.....	8
Input and output terminals	9
Connection HIREL 16x2	9
Specific technical data	10
Programming unit dimensions	10
Power unit dimensions	11

General information

This datasheet is a **supplement** to the manual for the freely programmable universal controller UVR16x2 and describes the **differences** and **additional** functions of the version UVR16x2E in comparison with the standard device (UVR16x2K or UVR16x2S).

Standard devices and UVR16x2E devices use the same operating system. The function data (configuration) is compatible, so the UVR16x2E controller can likewise be programmed using the program TAPPS2.

The UVR16x2E is intended for installation in an enclosed housing and has the connections and functions described below in accordance with the component location diagram (pages 4/5) and custom components (current sensors).

UVR16x2E-DE

The power unit of the UVR16x2E-DE forms a complete controller only in conjunction with the programming unit, as the processor is built into the programming unit.

Every power unit therefore requires the matching programming unit.

The power unit is connected to the programming unit via a ribbon cable. The ribbon cable is 700 mm long. For special applications, a ribbon cable 1100 mm long can be supplied as a special accessory.

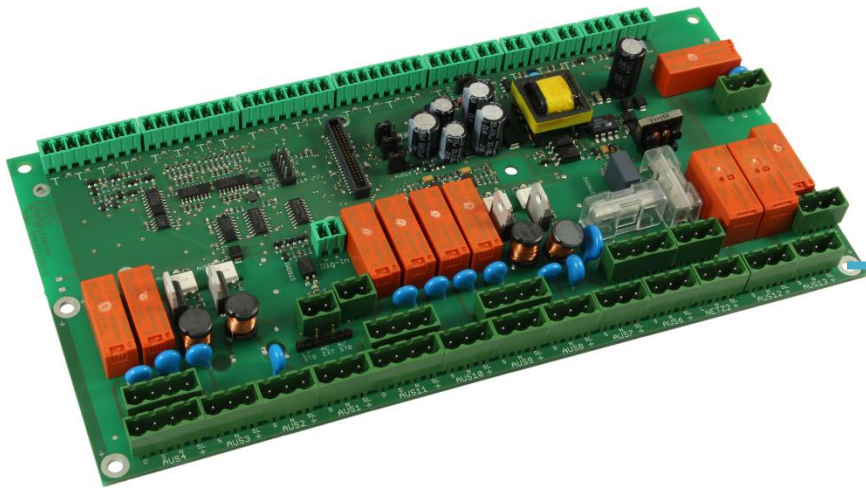

Power unit

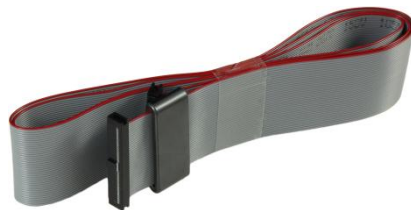

Ribbon cable



Programming unit

UVR16x2E-NP

Unlike the UVR16x2E-DE version, this version constitutes a complete controller with a processor module already built in. It is operated via the C.M.I. Control and Monitoring Interface.

The processor module has a card slot for a micro SD card (card included in standard delivery) and a reset button. The reset button and the micro SD card have the same functions as for the UVR16x2K and UVR16x2S versions and are described in the manuals for those versions.

The module is fastened to the power unit with screws and spacers and is connected to the power unit by a short ribbon cable.

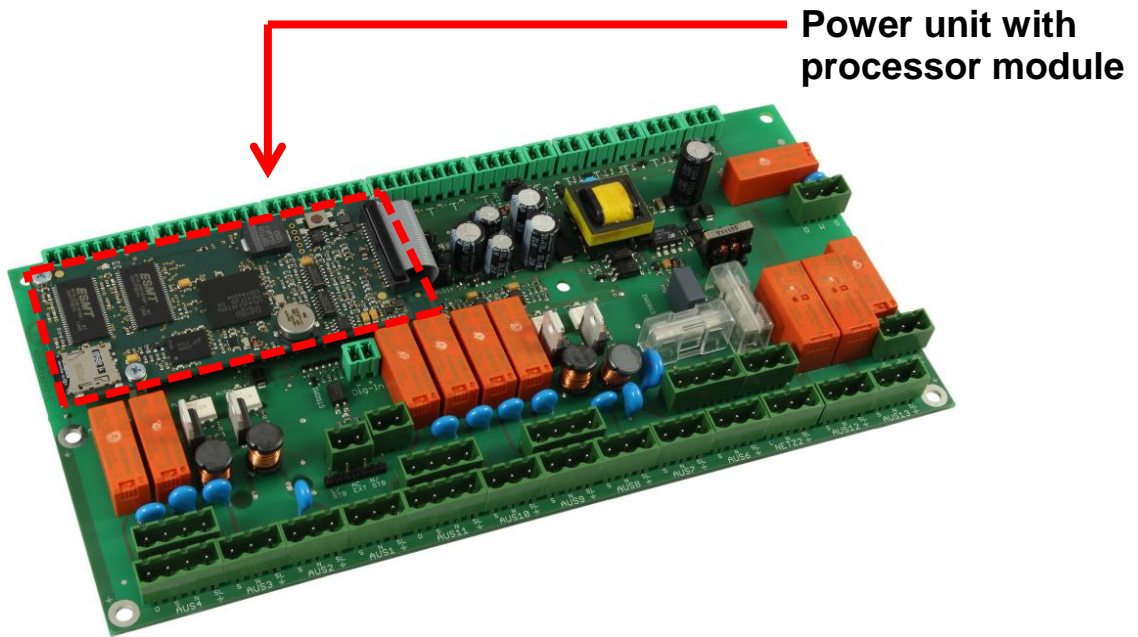

Processor module

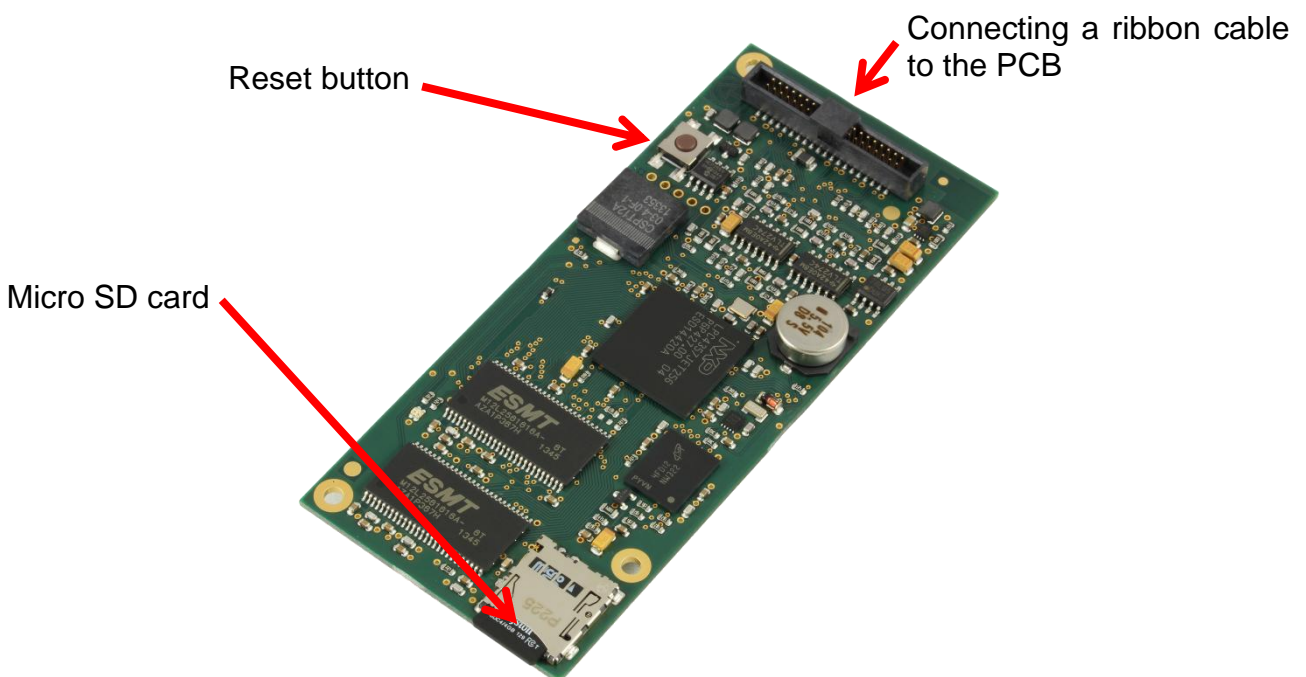

UVR16x2-E terminal diagram

Outputs 3/4, 8/9, 10/11
for mixer connection

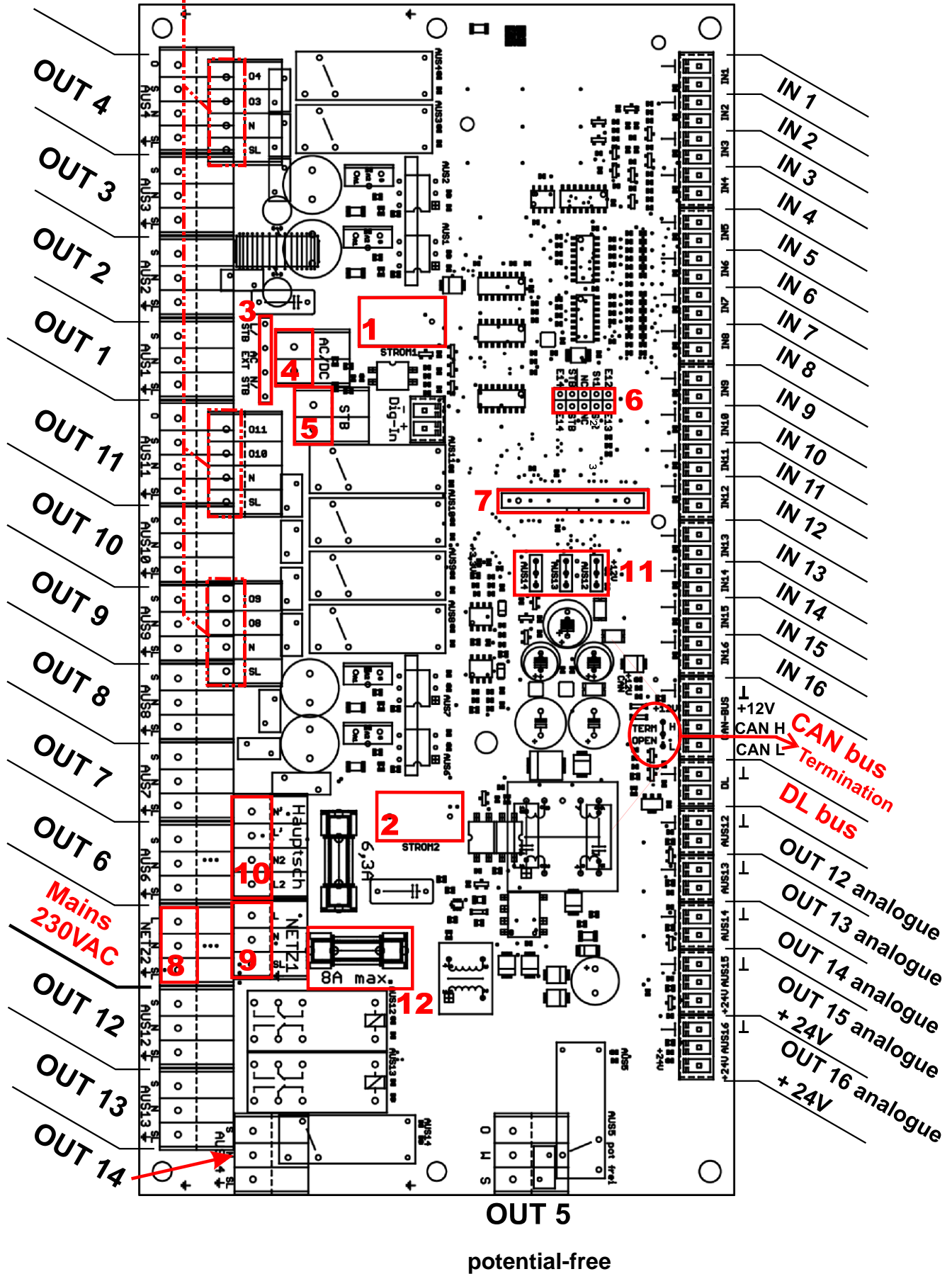

Schematic diagram of programming strips, switching outputs and mains connection

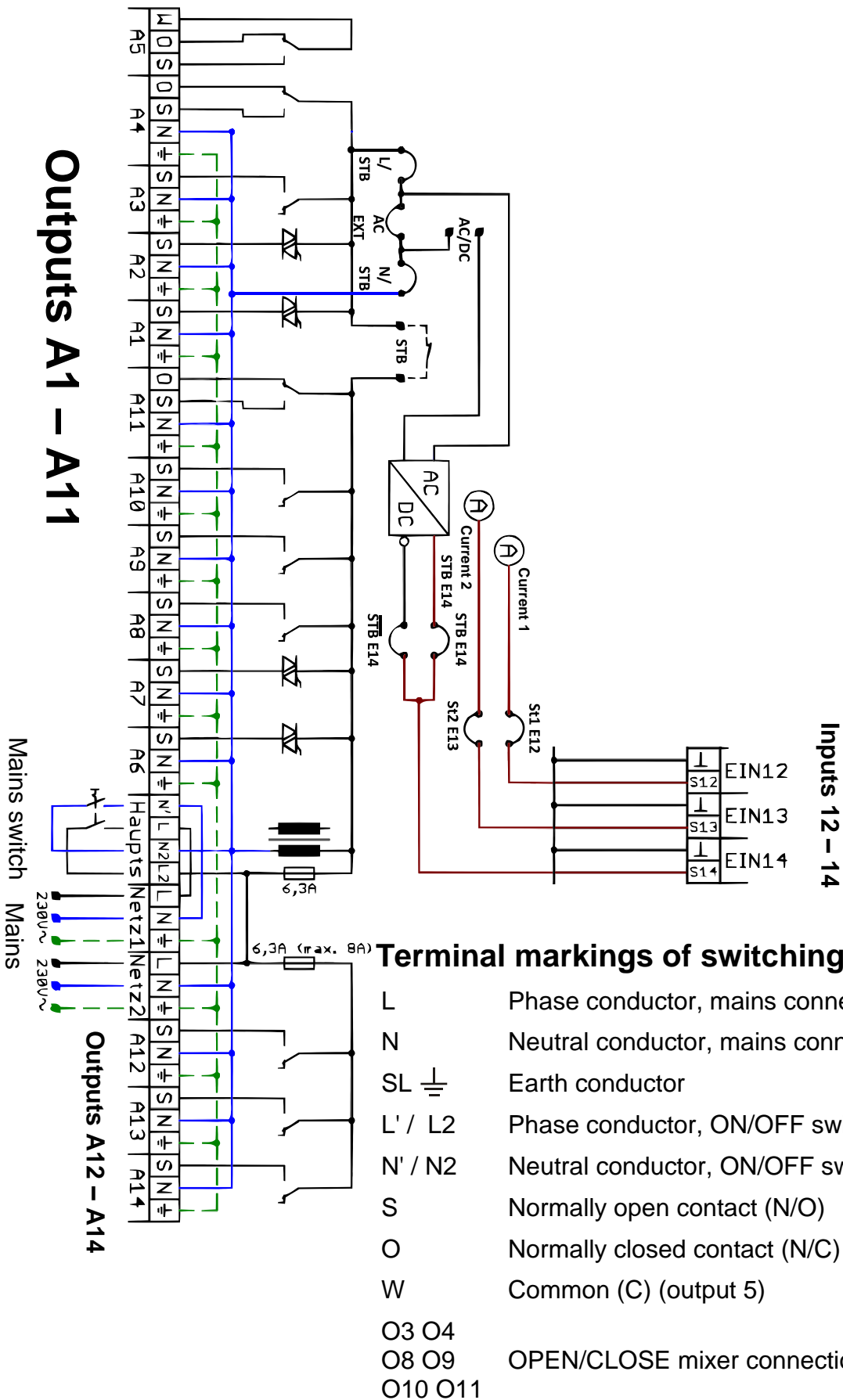

Current sensors 1-2, programming strips 3 and 6, AC/DC converter input 4, STB connection 5

1,2 **Current sensors** (included only at customer request):

A wire from the consumer requiring current measurement must be guided through the required sensor before the terminal clamp.

In addition, the measuring signal must be linked to a controller input via **programming strip 6**.

The corresponding input (12 or 13) must be programmed as an **analogue input** with the measured variable "**Voltage**" and the process variable "**Amperage A**" (operating system version V1.12 and higher).

Scaling: 0.00 V : 0.0A
3.30 V : 10.0A

Currents up to 10 A AC can be measured.

The current sensors **cannot** be used to **meter** electrical energy.

3 View of **programming strip 3** on the PCB:

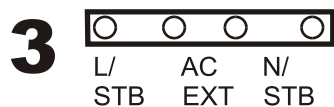

By positioning the **plug-in jumpers** accordingly, it is possible to achieve **either** high limit safety cut-out detection **or** the detection of a 230 V signal.

Plug-in jumpers for high limit safety cut-out detection

STB = high limit safety cut-out with potential-free, normally closed contact.

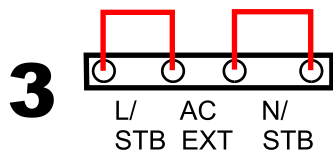

The **N/STB** and **L/STB** jumpers connect the **STB** of **connection 5** to **programming strip 6** for further processing via a detection circuit, with isolation.

At the same time the wire jumper (factory-set to **high limit safety cut-out connection 5**) must be repositioned to **connection 4 (AC/DC)**.

Plug-in jumper for detection of 230 V voltage

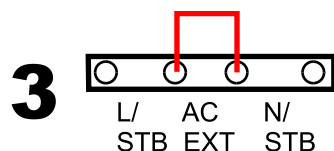

If the **AC/EXT** position is jumpered, the **230 V~ connection 4** is thus connected to **programming strip 6** for further processing via the detection circuit. In this case it is not possible to forward the high limit safety cut-out signal to the programming strip.

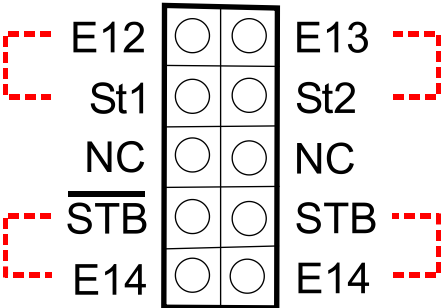
<p>4</p>	<p>AC/DC converter input for detection of an external 230 V AC signal instead of the high limit safety cut-out signal. This requires the AC/EXT jumper to be plugged into programming strip 3 so that the 230 V~ connection 4 is connected to programming strip 6 for further processing via the detection circuit.</p> <p>The PCB could be destroyed unless the N/STB and L/STB jumpers of programming strip 3 are both removed!</p>
<p>5</p>	<p>High limit safety cut-out connection: If a high limit safety cut-out is connected to these terminals, the outputs OUT1 to OUT4 become zero volt in the event of a safety shutdown. This state can be detected by the controller at the same time (see 3 and 6). Without a high limit safety cut-out, a jumper must be positioned at connection 5 so that outputs OUT1 to OUT4 are supplied with power.</p>
<p>6</p>	<p>View of programming strip 6 on the PCB:</p> <div style="text-align: center;">  </div> <p>Programming strip 6: All the special signals provided by this electronics unit as additions to the standard UVR16x2 controller can be applied to normal 16x2 sensor inputs by means of this pin contact strip and plug-in jumpers.</p> <p>Plug-in jumper</p> <p>E12 - St1 Current measurement 1 is applied to input 12</p> <p>E13 - St2 Current measurement 2 is applied to input 13</p> <p>NC "Not Connected" = no function</p> <p>E14 - $\overline{\text{STB}}$ The voltage detection from 4 or 5 is inverted and applied to input 14. When voltage is present (e.g. high limit safety cut-out closed/normal operation) the controller detects a digital "OFF" signal or the measurement of a sensor connected to E14. When no voltage is present (e.g. high limit safety cut-out open/fault) the controller detects a digital "ON" signal at E14 or -999 °C.</p> <p>E14 - STB The voltage detection from 4 or 5 is applied normally to input 14. When voltage is present (e.g. high limit safety cut-out closed/normal operation) the controller detects a digital "ON" signal at E14 or -999 °C. When no voltage is present (e.g. high limit safety cut-out open/fault) the controller detects a digital "OFF" signal or the measurement of a sensor connected to E14.</p>

Ribbon cable 7, mains connection 8-10, jumper 11 and fuse 12 for outputs 12-14

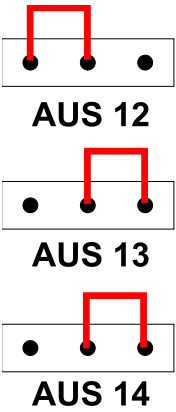
<p>7</p>	<p>Ribbon cable connection for programming unit or processor module</p> <p>The connector has a lug preventing it from being connected the wrong way round.</p> <p>Length of the cable to the programming unit: approx. 70 cm</p>
<p>8</p>	<p>Mains 2: Direct 230 V AC mains voltage connection without ON/OFF switch</p>
<p>9</p>	<p>Mains 1: Mains voltage connection when an external 2-pole ON/OFF switch (10) is used</p>
<p>10</p>	<p>Connection of the external two-pole ON/OFF switch which establishes the electrical connection from Mains 1 (10) to the entire internal power distribution network (including Mains 2 = 9).</p>
<p>11</p>	<p>Jumper for selection of the output type for outputs 12-14 (switching output or analogue output)</p> <p>Plugging the jumper into the left or right position selects the output type.</p> <p>Example:</p> <div style="display: flex; align-items: center;"> <div style="margin-right: 20px;">  </div> <div> <p>Jumper left: output 12 = switching output</p> <p>Jumper right: outputs 13 and 14 = analogue outputs</p> </div> </div> <p>If the output is set as a switching output and is also programmed accordingly in the function data, the corresponding relay will be switched and will connect 230 V to the terminals on the mains power side.</p> <p>If the output is set and programmed as an analogue output, the relay will not be switched and the required analogue signal (0-10 V or PWM) will be made available at the output terminals on the low voltage side.</p> <p>If outputs 15 and 16 are to be used as switching outputs, auxiliary relay HIREL61x2 must be used.</p>
<p>12</p>	<p>Common fuse protection (max. 8 A slow) for outputs OUT 12, 13 and 14. However, the maximum load for any individual relay is only 3 A.</p>

Input and output terminals

Safety low voltage side:

The inputs **IN 1** to **IN 16** are the same in technical terms as the normal inputs on the UVR16x2.

The two connections **OUT15** and **OUT16** (analogue outputs) have an additional connection for **24 V DC** voltage to supply external devices.

The **combined total load** of all devices with 12 V and 24 V supply must not exceed **6 W**.

The **termination** for the CAN bus must be carried out with a plug-in jumper in accordance with the CAN bus instructions (see UVR16x2 installation instructions).

Mains power side:

The outputs **OUT 1** to **11** are the same in technical terms as the normal UVR16x2 outputs.

Voltage is only applied to **OUT 1** to **4** when connector **5** (high limit safety cut-out) is jumpered.

Output pairs **OUT 3/4**, **8/9** and **10/11** are **additionally** fitted with a four-pin shared slot for mixer applications.

Outputs **OUT 12**, **13** and **14** have a dedicated common fuse for up to 8 A (slow) for somewhat higher loads (although the maximum load for any individual relay is only 3 A).

Connection HIREL-230V

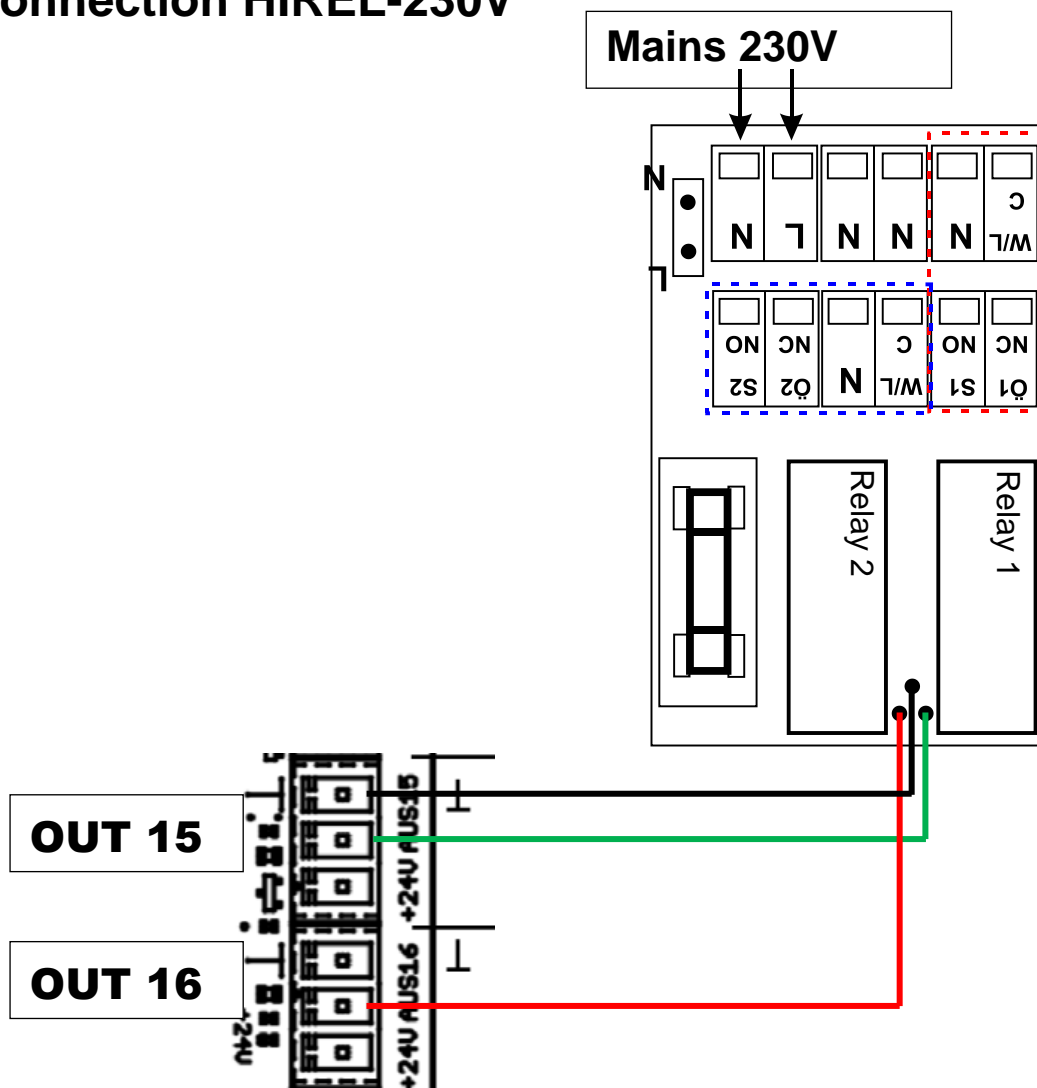

Specific technical data

Outputs 12 – 14	Can be either switching outputs or analogue outputs; relay for switching outputs already fitted so no auxiliary relay required Additional fuse protection - factory fitted: 6.3 A fast, max. 8 A slow
Current measurement accuracy	+/- 3 % of the measurement
Power consumption UVR16x2E-DE UVR16x2E-NP	Min. 2.15 W (outputs and display off) – max. 4.8 W (all outputs on, display on with 100 % brightness) Min. 2.15 W (outputs off) – max. 3.82 W (all outputs on)
IP rating Power unit Programming unit	IP00 (only suitable for installation in an enclosed housing) IP40
All other technical data matches that of the standard version UVR16x2.	

Programming unit dimensions

in mm

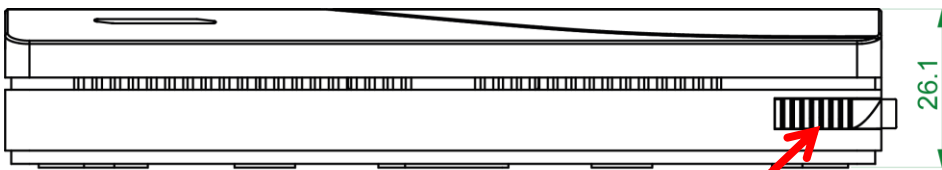

Programming stylus

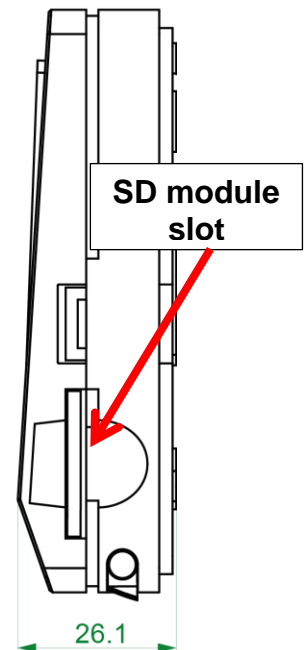
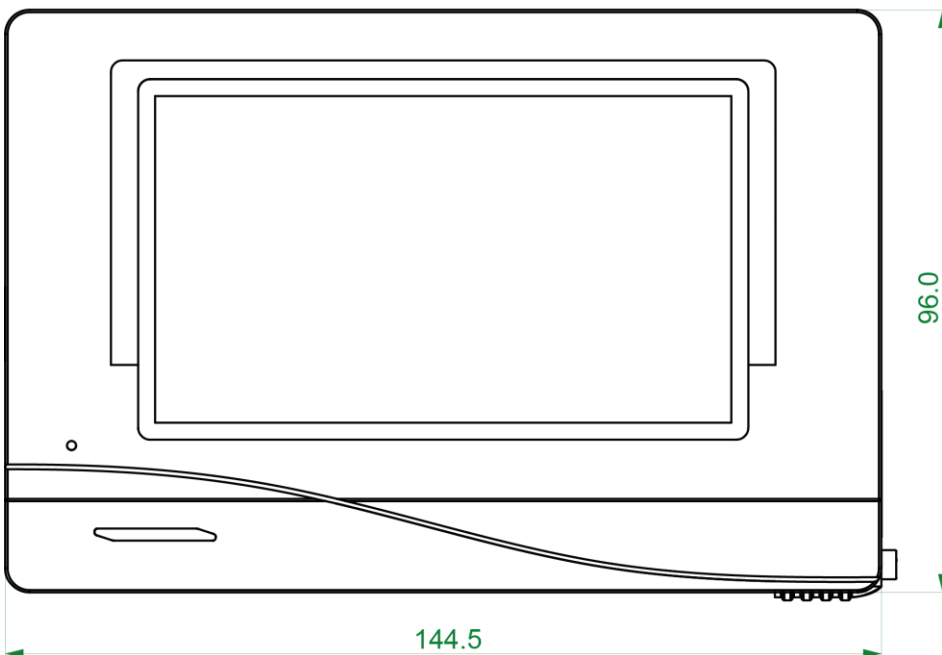

Power unit dimensions

in mm:

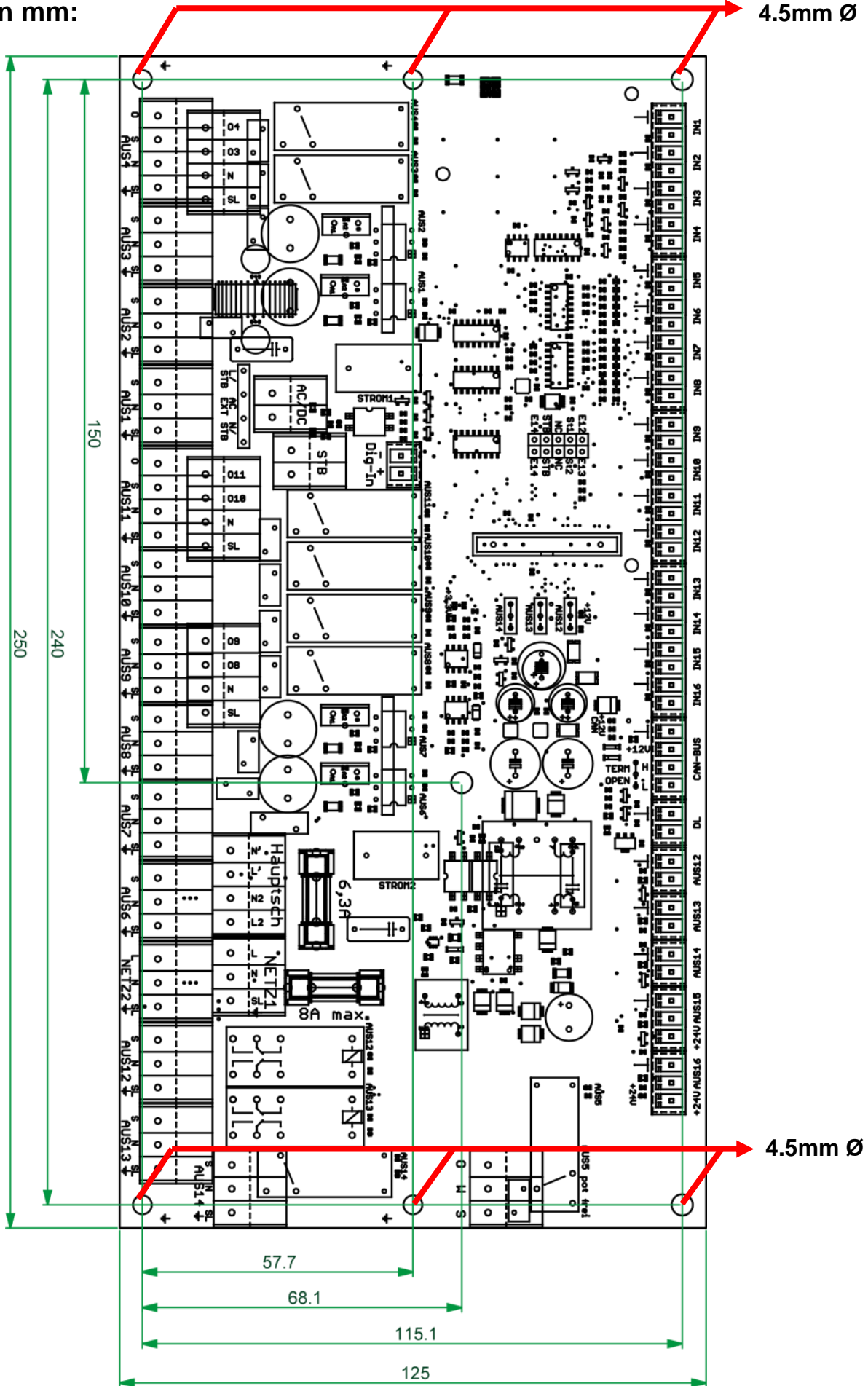

Subject to technical modifications

© 2016

Legal notice

This operating manual is protected by copyright.

Use outside the copyright requires the consent of Technische Alternative RT GmbH. This applies in particular to reproductions, translations and electronic media.

Technische Alternative RT GmbH

A-3872 Amaliendorf Langestraße 124

Tel ++43 (0)2862 53635

Fax ++43 (0)2862 53635 7

E-Mail: mail@ta.co.at

--- www.ta.co.at ---



© 2017