



EHS-R

ADJUSTABLE ELECTRIC IMMERSION HEATER



Installation

Table of contents

| | |
|---|-----------|
| Safety requirements | 4 |
| Maintenance | 5 |
| Disposal | 5 |
| Function description | 6 |
| Programming | 6 |
| Wireless control | 6 |
| Control via CORA-DL | 6 |
| PWM control | 6 |
| Installation and connection | 7 |
| Dimensioned drawing | 7 |
| High limit safety cut-out (HLSC) | 8 |
| Sensor installation, PWM input | 8 |
| Mains connection | 9 |
| Heating elements | 9 |
| Wireless system | 10 |
| Principles | 10 |
| Pairing devices | 10 |
| Transmitted values | 10 |
| Fault codes | 10 |
| Relaying wireless signals | 11 |
| CORA-DL (cable instead of wireless) | 11 |
| Connection | 11 |
| Operation | 11 |
| Reset/pairing | 12 |
| LED status indicators | 12 |
| Possible LED indicators | 13 |
| Firmware-Update via CAN-EZ3 | 13 |
| Technical data | 14 |

Safety requirements



All installation and wiring work on the controller must only be carried out in a zero volt state. The opening, connection and commissioning of the device may only be carried out by competent personnel. While doing so, they must observe all local safety requirements.

This device is state of the art and meets all necessary safety regulations. It may only be used in accordance with the technical data and the safety requirements and regulations listed below. When using the device, also observe the statutory and safety regulations apposite to the particular use. Any other use will automatically void all warranty rights.

- Connection work and other exposure of the PCB in the immersion heater casing should only be carried out in a dry interior room.
- It must be possible to isolate the immersion heater from the mains, in accordance with local regulations, using an omnipolar isolating facility (plug/socket or 2-pole isolator).
- The immersion heater should only be connected to a mains socket using the supplied connecting cable. The connecting cable should be fitted before insertion. The mains socket must have at least 16 A fuse protection.
- No extension cables, mains distributors or cable drums should be used.
- Before starting installation or wiring work on equipment, the immersion heater must be completely isolated from the mains and protected against a restart.
- Never pull on the mains cable, or pull the mains plug out of its socket by the cable.
- Safe operation is no longer possible if the immersion heater, or connected equipment shows signs of visual damage, no longer functions or has been stored for lengthy periods in unfavourable conditions. If this is the case, disable the devices or equipment and secure against unintentional use.
- At the immersion heater, high temperatures occasionally occur during operation, which should be taken into consideration during installation/maintenance work. Also never touch the immersion heater with wet/damp hands. Insulated footwear is recommended for installation work.
- The immersion heater may be active at a high output level for a prolonged period of time. Relevant components (e.g. sockets) must be able to withstand current flows of up to 16 A for prolonged periods.

Maintenance

If treated and used correctly, the device itself will not require any maintenance. However, the use of a suitable **sacrificial anode** in the cylinder is recommended, and if the immersion heater is used more often than usual, it is necessary to check whether the material thickness is reduced (at least 2-3 times per year).

No components relevant to long term accuracy are subject to loading if the device is used correctly. Consequently long term drift is extremely low. The device therefore does not require any maintenance and cannot be adjusted.

The structural characteristics of the device must not be changed during repairs. Spare parts must correspond to the original parts and must be used in accordance with the build version.

Disposal



- Devices no longer in use or beyond a state of repair must be disposed of in an environmentally responsible manner by an authorised collection point. They must never be treated as ordinary household waste.
- We can undertake the environmentally responsible disposal of devices sold by the Technischen Alternative company upon request.
- Packaging material must be disposed of in an environmentally responsible manner.
- Incorrect disposal may result in considerable damage to the environment, as many of the materials used require professional handling.



Function description

The **EHS** immersion heater is available in two versions:

- **EHS-R**: With variable control from 40 W - 3000 W
- **EHS**: Output 0-3000 W in 750 W increments

Combining an **EHS-R** (controllable) with one or multiple **EHS** (not controllable) enables a cascade to be set up in which the **EHS-R** carries out fine adjustment, achieving stepless power regulation.

Both versions can be controlled wirelessly from a **CAN-EZ3** to control their output and exchange data.

Alternatively, the immersion heater has a PWM input to allow direct control of the output (non-wirelessly).

More details on the wireless system can be found in the chapter of the same name.

Programming

The **EHS** itself does not require any programming; its output is defined by other devices. If the immersion heater is used in conjunction with freely programmable controllers, the use of the **Energy manager** and **Output control** functions is recommended (more details in the instructions for the "Functions" of the freely programmable controller).

Wireless control

For wireless control, the immersion heater must be paired with the device controlling it. If a **CAN-EZ3A** and an **EHS-R** in the **ATON** set were purchased together, they have already been paired at the factory.

More details on the wireless system can be found in the chapter of the same name.

Control via CORA-DL

The full functional scope of the **EHS-R** can also be achieved via cable.

This functionality is only available on the **EHS-R** from version 1.09 and serial number 002500 onwards.

The immersion heater is connected to the **DL** bus of a controller (**DL** master, e.g. **UVR16x2/UVR610**), where it is programmed under "CORA devices".

Page 11 contains connection information relating to the immersion heater.

The manual for the relevant controller contains further information about connection, programming and minimum software requirements.

PWM control

To operate the **EHS-R** without a wireless connection (e.g. in conjunction with controller **UVR16x2**), the immersion heater has a PWM input. 10-90 % PWM corresponds to 0-3000 W output, but operation only starts at min. 45 W (equates to around 12 % PWM).

For the PWM input connection graphic, see chapter "**Sensor installation, PWM input**".

| PWM | Output | Recommended thresholds |
|--------|--------|------------------------|
| <20% | 0 W | 10% |
| 20-40% | 750 W | 30% |
| 40-60% | 1500 W | 50% |
| 60-80% | 2250 W | 70% |
| >80% | 3000 W | 90% |

We recommend using a **range function** to output a PWM signal according to the thresholds specified below. This compensates for any fluctuations/inaccuracies of the PWM signal.

Important: If an active wireless connection is available (paired and signals being received), the PWM input is **inactive**. If the immersion heater is controlled via the PWM input, the wireless pairing of other devices with the **EHS-R** must be deleted.

Installation and connection



Use in DHW cylinders

We expressly advise against using our immersion heater in DHW cylinders!

The immersion heater is intended for installation in buffer cylinders in which the same heating water always circulates.

We do not offer any guarantee or warranty in the case of limescale or galvanic corrosion!

Observe the safety requirements on page 4!

Dimensioned drawing

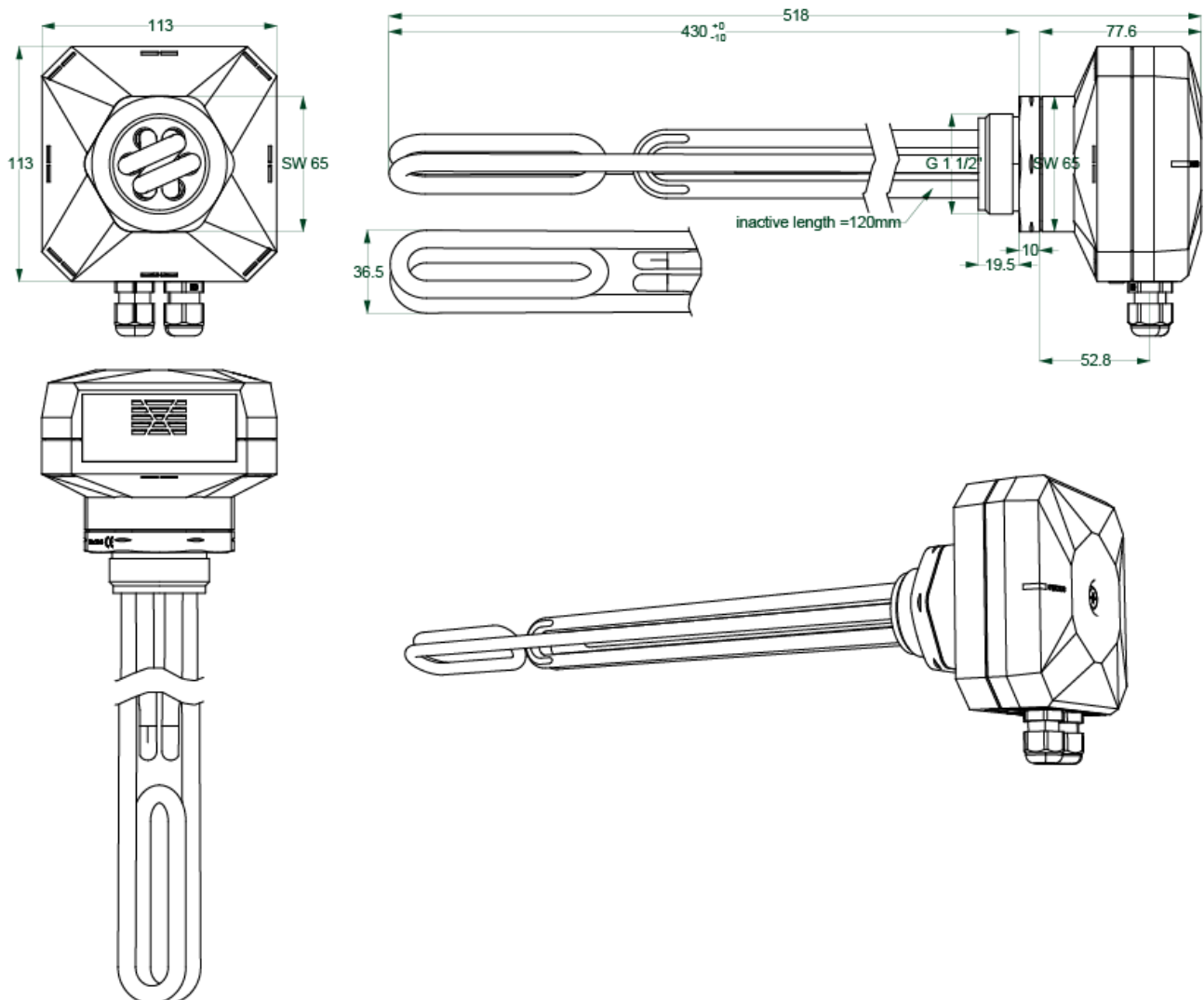

cold zone = distance from threaded head, which is not heated (120 mm)

The immersion heater must be installed horizontally in the cylinder. The ventilation slots must be at the top and bottom.

Do not start up the immersion heater if it is not in water.

High limit safety cut-out (HLSC)

The EHS-R has a sensor for the high limit safety cut-out. This is a PT1000 sensor in a sensor well between the heating elements. It is connected at the factory at the connection shown below.

When a temperature of 95 °C is reached at the STB sensor, the immersion heater is deactivated. The immersion heater must then be restarted manually (click button once, disconnect and reconnect power cable of immersion heater, or restart via the CAN-EZ3).

The electronics temperature is also monitored. Their maximum temperature is 75 °C (5 K hysteresis).

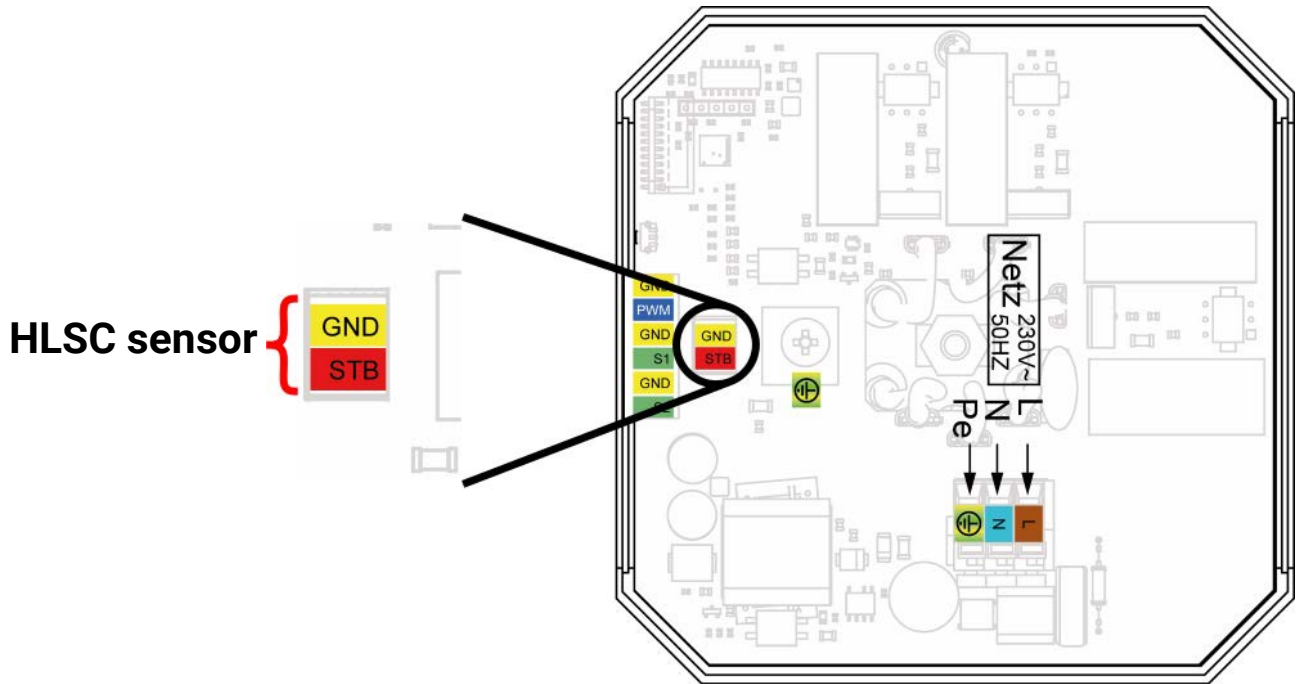

Sensor installation, PWM input

The EHS-R has 2 sensor inputs, which are only suitable for connection of **PT1000 sensors**. The measurements of these sensors are transferred via the CORA wireless connection. This establishes the connection for **PWM control**. More detailed information can be found in the chapter of the same name.

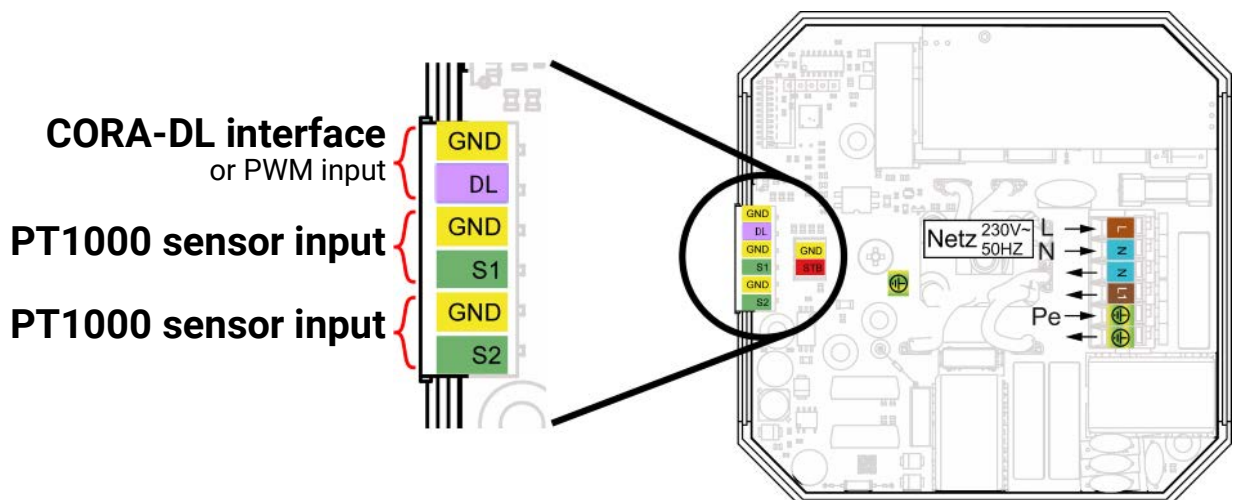

Mains connection

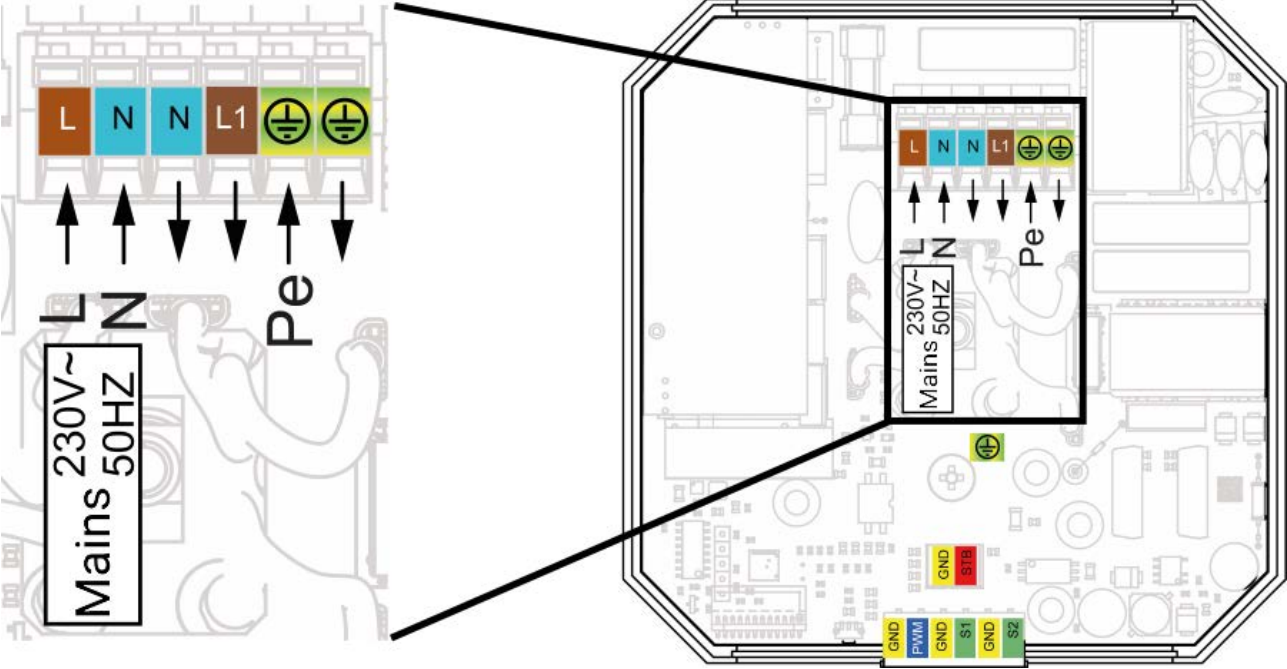

| | |
|----|-------------------|
| L | Phase |
| N | Neutral conductor |
| Pe | Earth conductor |

Heating elements

The 3 heating elements are connected at the factory and fully wired. For any installation/maintenance work, ensure correct wiring/connection.

The EHS-R has 3 heating elements:

- 750 W controllable
- 750 W not controllable
- 1500 W not controllable

The connections of the heating elements (as they are routed from the threaded head and through the PCB) must not be interchanged. By the orientation of the screw at the edge of the threaded head, the heating elements and their connections can be identified.

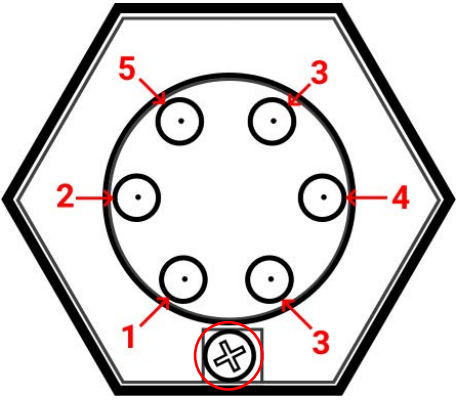

Heating elements

- 1 750 W not controllable
- 2 1500 W not controllable
- 3 750 W controllable
- 4 Neutral conductor 1500 W not controllable
- 5 Neutral conductor 750 W not controllable

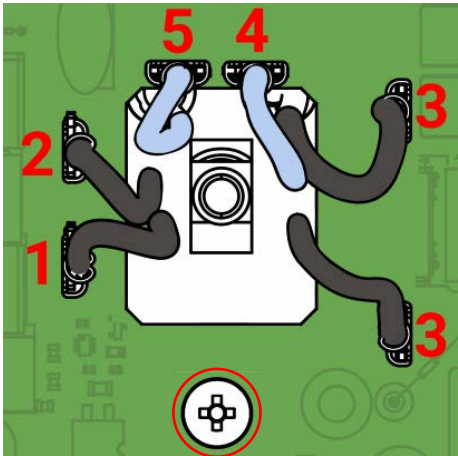

Connections on PCB

The two neutral conductors (4 and 5) can be swapped. The two connections of the controllable heating element (3) are reverse polarity-protected. For the remaining wires, the polarity must be observed.

Wireless system

Principles

The wireless system comprises at least two devices (e.g. CAN-EZ3 and EHS-R), which communicate with one another, exchange data or send firmware/function data.

The wireless range is around 1000 m outdoors, and typically 30 m in buildings (through approx. 2 walls/ceilings, depending on thickness and material). Up to 3 additional wireless-capable devices can be used as a bridge to enable data to be exchanged under deviating conditions.

RCV-DL, GBS-F and RAS-F devices **cannot** be used.

Pairing devices

Two steps are carried out to pair two devices:

1. **Allow** pairing on the **target device**
2. **Initiate** pairing on the **control device**

To allow pairing on the EHS-R (= target device), **double click** on the button on the casing (= 2 click within 2 seconds). Pairing is then allowed for **5 minutes** (see chapter "**Reset / Pairing**").

On the control device, the x2 wireless ID for the EHS-R is required for pairing.

The pairing process on other devices (*control device*) can be found in the corresponding operating instructions.

If a CAN-EZ3A and an EHS-R in the **ATON** set were purchased together, they have already been paired at the factory.

Transmitted values

The following values are transmitted from the EHS-R to the paired device (cannot be changed):

| | |
|----------------------------|--|
| Timeout | Digital value Yes/No (Yes, if wireless connection is lost) |
| Current output | Output that is currently being consumed by the EHS-R |
| <i>Higher output level</i> | <i>Only used for internal calculation</i> |
| <i>Lower output level</i> | |
| Temperature 1 | Temperature at sensor input 1 (PT1000 sensor) |
| Temperature 2 | Temperature at sensor input 2 (PT1000 sensor) |
| HLSC temperature | Temperature of sensor for high limit safety cut-out |
| Electronics temperature | Temperature at immersion heater PCB |
| Fault code | If faulty operation is identified on the EHS-R, the corresponding fault code is transmitted. |

Fault codes

A number is assigned to each fault status. The sum of the codes of all current faults is output under "Fault codes". The entry "Fault codes" can be found under the outputs of the corresponding CORA device.

| | |
|---|----------------------------|
| 1 | Faulty fuse |
| 2 | Excess temperature at HLSC |
| 4 | Excess temperature at PCB |

Relaying wireless signals

Wireless-capable devices can relay signals of other devices. All required settings for this are carried out at the device, which transmits the signal to be relayed. The EHS-R can be used to relay wireless signals.

If the EHS-R immersion heater receives signals via a relay, it automatically returns data via the same relay. No settings are therefore required for the relay on the EHS-R.

CORA-DL (cable instead of wireless)

The immersion heater can also be used with a cabled connection. This replaces all functions of the wireless system. The immersion heater cannot be run with a wireless and a cabled connection at the same time.

This function is only available on the EHS-R from version **1.09** and serial number **002500** onwards.

Connection

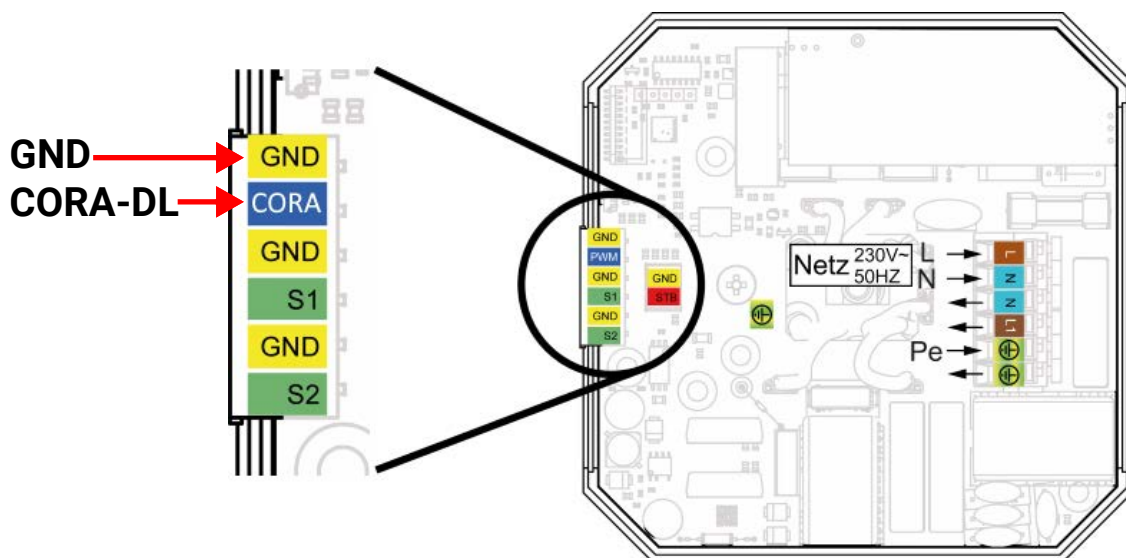

It is important to note the polarity. The **CORA** connection on the immersion heater is connected to **DL** on the controller, and **GND** to **GND**.

Operation

Operation of an EHS-R connected via CORA-DL is no different to wireless operation. Operation is described in the instructions of the master device (e.g. CAN-EZ3).

Reset/pairing

The button is pressed using a narrow-tip pen.

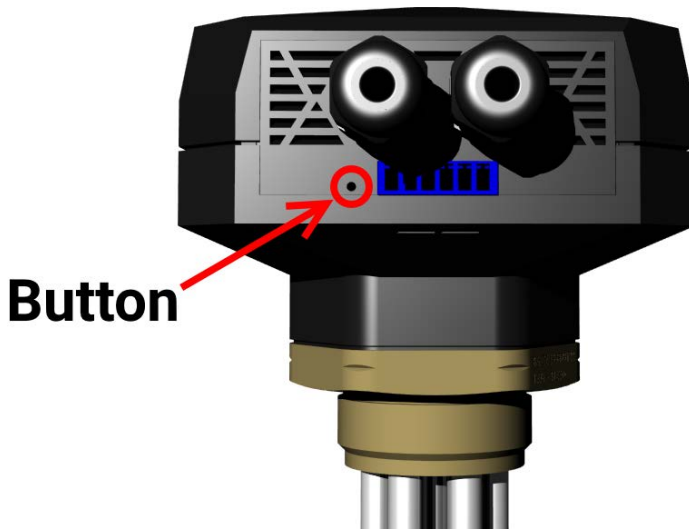

| | |
|--|--|
| Double click (two clicks within 2 seconds) | Allow pairing for 5 minutes (see chapter "Wireless system") The LED flashes green rapidly for 3 seconds to confirm. |
| 10-second click | Total reset (hold until the LED shows a green light for 1 second) After a total reset, pairing is allowed until the first successful pairing attempt, with no time limit. |
| Click once | Reset (software restart) |

LED status indicators



Possible LED indicators

| Control indicator | Explanation |
|-------------------------------------|---|
| Green, steady light | Set output 0 W is preset wirelessly or via CORA-DL or Set output via PWM input > 0 W but < 50 W |
| Green, slow flashing | Set output > 0 W is preset wirelessly |
| Green, quick flashing | Set output > 0 W is preset via PWM input If the LED flashes rapidly for only 3 seconds, pairing has been permitted via the pushbutton. |
| Orange/red alternate, slow flashing | Faulty circuit breaker |
| Orange, steady light | No wireless signal received for at least 2 minutes and no PWM signal received |
| Orange, slow flashing | Immersion heater excess temperature (HLSC >95 °C) – a restart is required (via CORA connection or briefly cut the power supply) |
| Orange, quick flashing | Casing/PCB excess temperature (>75 °C) |
| Red, steady light | Internal fault |
| Red, slow flashing | Wireless chip error |
| Red, quick flashing | EEPROM error |

Firmware-Update via CAN-EZ3

The firmware of the EHS-R immersion heater can be updated via a wireless CAN-EZ3 (see chapter "Wireless system" on page 10).

The firmware file of the EHS-R must be located on the SD card of the CAN-EZ3.

Data admin

Function data

↓

Firmware

Load...

In the Data admin menu, navigate down to Firmware. Select Load... below this.

Data admin

Firmware

Load...

□..

⊞ EHS_U1_05.DE. ⊕

bin

⊞ EHS_U1_05.DE. -

bin

X I ↑

Select the plus symbol next to the required firmware file (not the file itself).

In the toolbar that appears, select the arrow symbol for sending data.

Do you really want to send the file to the selected node?
"CAN_EZ3_U1_07.bin"

1: EHS 1

✓
X

In the list, select the corresponding device (only paired CORA devices are shown) and confirm with ✓.

The firmware update starts. It may take a few minutes.

Technical data

| | |
|----------------------------------|---|
| Power consumption | max. 3000W (depending on specified set output) |
| Nominal voltage | 230V, 50 Hz |
| Surface heat output | < 10 W/cm ² |
| Cold zone | 120mm (± 10mm) |
| Screw | G 1 ½" SW 65 |
| Fuse | 6,3A fast (only for adjustable heating element and electronics) |
| Wire size | 3 x 1,5 mm ² |
| Dimensions | see „ Dimensioned drawing “ |
| PWM-input | 400 Hz - 4 kHz 9-13 V |
| Frequency of wireless system | 868.5 MHz |
| Transmission output | -10 dBm |
| Sensor inputs | PT1000 |
| DL bus load (when using CORA-DL) | 10 % |
| Heating element material | stainless steel 1.4541 |

Subject to technical modifications as well as typographical and printing errors. This manual is only valid for devices with the corresponding firmware version. Our products are subject to constant technical advancement and further development. We therefore reserve the right to make changes without prior notice.

© 2023

EU Declaration of conformity

Document-Nr. / Date: TA19002, 19/07/2019
Company/Manufacturer: Technische Alternative RT GmbH
Address: A-3872 Amaliendorf, Langestraße 124

This declaration of conformity is issued under the sole responsibility of the manufacturer.

Product name: EHS, EHS-R
Product brand: Technische Alternative RT GmbH
Product description: Electronic immersion heater

The object of the declaration described above is in conformity with Directives:

2014/35/EU Low voltage standard
2014/30/EU (11/09/2018) Electromagnetic compatibility
2011/65/EU (01/10/2022) RoHS Restriction of the use of certain hazardous substances

Employed standards:

| | |
|--------------------------|--|
| EN 60730-1:2021-06 | Automatic electrical controls - Part 1: General requirements |
| EN IEC 61000-6-3:2022-06 | Electromagnetic compatibility (EMC) - Part 6-3: Generic standards - Emission standard for equipment in residential environments |
| EN IEC 61000-6-2:2019-11 | Electromagnetic compatibility (EMC) - Part 6-2: Generic standards - Immunity standard for industrial environments |
| EN IEC 63000:2019-05 | Technical documentation for the assessment of electrical and electronic products with respect to the restriction of hazardous substances |
| EN 300220-2:2018-09 | Short Range Devices (SRD) operating in the frequency range 25 MHz to 1 000 MHz - Part 2: Harmonised Standard for access to radio spectrum for non specific radio equipment |
| EN 301489-1:2020-06 | ElectroMagnetic Compatibility (EMC) standard for radio equipment and services - Part 1: Common technical requirements - Harmonised Standard for ElectroMagnetic Compatibility |
| EN 301489-3:2019-08 | ElectroMagnetic Compatibility (EMC) standard for radio equipment and services - Part 3: Specific conditions for Short-Range Devices (SRD) operating on frequencies between 9 kHz and 246 GHz |

Position of CE - label: On packaging, manual and type label



Issuer: Technische Alternative RT GmbH
A-3872 Amaliendorf, Langestraße 124

This declaration is submitted by

Dipl.-Ing. Andreas Schneider, General manager,
19/07/2019

This declaration certifies the agreement with the named standards, contains however no warranty of characteristics.

The security advices of included product documents are to be considered.

Warranty conditions

Note: The following guarantee conditions do not limit the legal right to a warranty, but rather expand your rights as a consumer.

1. Technische Alternative RT GmbH provides a one year warranty from the date of purchase for all the devices and parts which it sells. Defects must be reported immediately upon detection and within the guarantee period. Technical support can supply the correct solution for almost every known problem. In this respect, contacting us immediately will help to avoid unnecessary expense and effort in troubleshooting.
2. The guarantee includes free repair (but not the cost of on-site fault finding, removal, refitting and shipping) due to operational and material defects which impair operation. In the event that a repair is not economical in the opinion of Technische Alternative for reasons of cost, the goods will be replaced.
3. Not included is damage resulting from the effects of a voltage surge or abnormal ambient conditions. Likewise, no liability can be accepted if the device defect is due to: transport damage for which we are not responsible, incorrect assembly and installation, incorrect use, failure to observe the operating and installation instructions or incorrect maintenance.
4. The guarantee will become void if repairs or actions are carried out by people who are not authorised to perform them or have not been so authorised by us or if our devices are operated with spare parts, auxiliary parts or accessories that are not considered to be original parts.
5. The defective parts must be returned to our factory with a copy of the proof of purchase and a precise fault description. Processing is accelerated if an RMA number is requested via our homepage www.ta.co.at. The defect must be clarified with our technical support beforehand
6. Services provided under guarantee result neither in an extension of the guarantee period nor in a commencement of a new guarantee period. The guarantee period for fitted parts ends with the guarantee period of the whole device.
7. Further or other claims, especially those for compensation for damage other than to the device itself, insofar as a liability is not legally required, are excluded.

Legal notice

These installation instructions are protected by copyright.

Use outside the copyright requires the consent of Technische Alternative RT GmbH. This applies in particular to reproductions, translations and electronic media.

Technische Alternative RT GmbH

A-3872 Amaliendorf, Langestraße 124

Tel.: +43 (0)2862 53635

Fax +43 (0)2862 53635 7

E-Mail: mail@ta.co.at

--- www.ta.co.at ---



©2019