

UVR 63H

Version 7.6 EN

Universal heating controller



Operation
Installation instructions

en

Contents

Safety requirements	4
Maintenance	4
Generally applicable rules	5
Hydraulic diagrams	6
Diagram 0: Heating circuit with up to 2 heat sources	6
Diagram 16: Automatic boiler, cylinder, heating circuit (without mixer), burner demand	8
Diagram 64: Boiler circuit pump, mixer for return flow booster	12
Scheme 80: Heating circuit, (automatic) boiler, cylinder, charging pump	14
Version 1: Automatic boiler, buffer cylinder, buffer charging pump	14
Version 2: Automatic boiler, buffer cylinder, DHW cylinder charging pump	15
Version 3: Solid fuel boiler, buffer cylinder and DHW cylinder charging pump	16
Diagram 96: Automatic boiler, heating circuit (with electrothermal mixer), burner demand	18
Diagram 112: Heating circuit (with electrothermal mixer), DHW cylinder	20
Diagram 128: Heating circuit with burner demand, switchover to cooling with cooler demand	22
Installation instructions	24
Sensor installation	24
Sensor lines	24
Installing the device	25
Electrical connection	25
Special connections	26
Operation	27
Change a value (parameter)	27
The basic control level	28
Optional displays in the basic control level	30
The status display	31
The time program menu	32
Date setting <i>DATE</i>	33
The parameter menu <i>Par</i>	34
Setting method heat curve <i>TEMP / R RISE</i>	35
Frost protection <i>OTF / RTF</i>	37
Automatic / manual mode	38
<i>O AUTO</i>	38
<i>M AUTO</i>	38
<i>C AUTO</i>	39
The main menu <i>Men</i>	39
Summary	40
Language <i>DEUT, ENGL</i>	40
Code number <i>CODE</i>	40
Sensor menu <i>SENSOR</i>	40
Sensor type	41
Determination of average <i>AV</i>	42
Symbol allocation <i>AIC</i>	43
Mixer menu <i>MIXER</i>	44
Heating pump menu <i>PUMP</i>	45
Pump speed control <i>PSC</i>	48
Control output <i>COP 0</i> to 10 V / PWM (twice)	50
Heat quantity meter <i>HQC</i> (three times)	56
External sensors <i>EXT DL</i>	59
Tips on troubleshooting	60
Table of settings	61
Information on the Eco-design Directive 2009/125/EC	64
Technical data	65

Safety requirements



These instructions are intended exclusively for authorised professionals. All installation and wiring work on the controller must only be carried out in a zero-volts state.

The opening, connection and commissioning of the device may only be carried out by competent personnel. In so doing, all local security requirements must be adhered to.

The device corresponds to the latest state of the art and fulfils all necessary safety conditions. It may only be used or deployed in accordance with the technical data and the safety conditions and rules listed below. When using the device, the legal and safety regulations apposite to the particular use are also to be observed. Incorrect use will result in the negation of any liability claims.

- ▶ The device must only be installed in a dry interior room.
- ▶ It must be possible to isolate the controller from the mains using an all-pole isolating device (plug/socket or double pole isolator).
- ▶ Before starting installation or wiring work, the controller must be completely isolated from the mains voltage and protected against being switched back on. Never interchange the safety extra-low voltage connections (sensor connections) with the 230V connections. Destructive and life-threatening voltages at the device and the connected sensors may occur.
- ▶ For safety reasons, the system should only be left in manual mode when testing. In this operating mode, no maximum temperatures or sensor functions are monitored.
- ▶ Safe operation is no longer possible if the controller or connected equipment exhibits visual damage, no longer functions or has been stored for a lengthy period of time under unsuitable conditions. If this is the case, place the controller and equipment out of service and secure against unintentional use.

Maintenance

The system does not require maintenance if handled and used properly. Use a cloth moistened with soft alcohol (such as spirit) to clean. Harsh cleaning agents and solvents such as chlorethenes or tri-gases are not admissible.

As the components relevant to accuracy are not subjected to loads if used properly, long-term deviation is very low. The unit thus cannot be adjusted. Hence, no calibration is possible.

The design characteristics of the unit must not be changed during repairs. Spare parts must correspond to the original parts used to restore the manufactured condition.

Generally applicable rules

for correct utilization of this control system

- ◆ The expression "**heating = active**" in the linking formulae relates only to the release specified in the "**PUMP**" menu or heating pump blockade conditions, but not however to a possible switching off or release of the heating pump via a minimum threshold value.
- ◆ If no room sensor is used, the room influence **RI** in the menu **MIXER** must be set to **Zero** and the sensor **S1** in the **SENSOR** menu set to **FIXED VALUE (e.g. 20°C)**.
- ◆ For use with floor and wall heating systems a safety thermostat is mandatory as required for conventional heating control units. To avoid consequential damage this has to switch off the heating circuit pump independently of controller output in the event of excess temperature.
- ◆ The speed control is only meaningful for certain conditions. One is use it to limit the return temperature of the heating circuit. In some cases it can even replace the mixer by using the speed control to hold the room temperature constant at the temperature specified in the time program. In some cases it can even replace the mixer by using the speed control to hold the room temperature constant at the desired temperature (although without the time program)

Additional functions

The following functions can be additionally activated via the main menu **ENTER/Men**:

- **Pump speed control *PSC***
- **2 control outputs *COP***
- **3 heat quantity meters *HQC***
- **External sensors *EXT DL***

Hydraulic diagrams

Diagram 0: Heating circuit with up to 2 heat sources

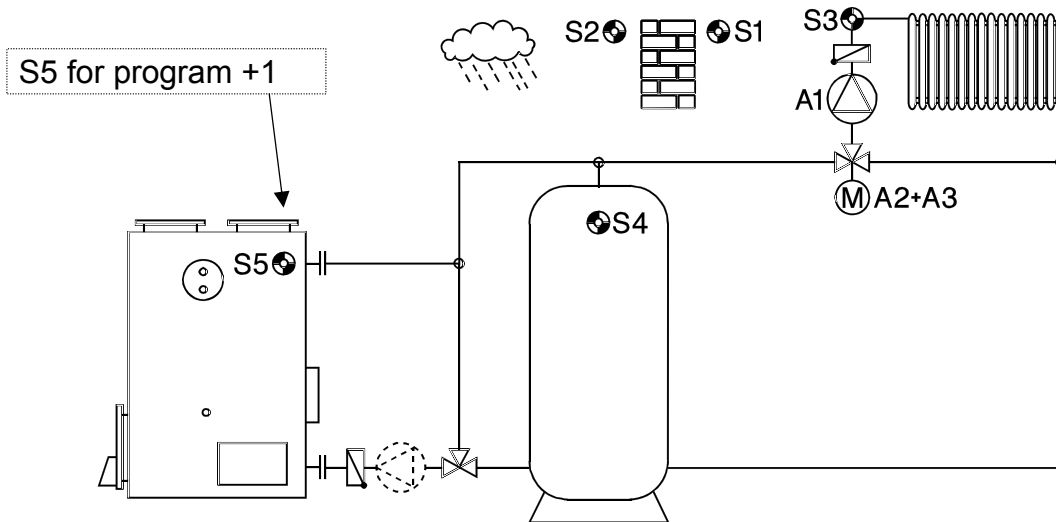

<p style="text-align: center;">A1 off S4 < min1</p> <p style="text-align: center;">-----</p> <p style="text-align: center;">A1 on</p> <p style="text-align: center;">↓</p> <p style="text-align: center;">-----</p> <p style="text-align: center;">Switch-off cond. PUMP A1 off</p>	<p>Required settings:</p> <p>Basic control level</p> <p>Time</p> <p>Operating mode (preferably AUTO)</p> <p>Set room temperature for lowering mode RTL</p> <p>Set room temperature for normal operation RTN</p> <p>Time program for normal operation</p> <p>Parameter menu</p> <p>Program number PR</p> <p>min1... cylinder S4 → A1 (if heating circuit active)</p> <p>min2 ... see all programs + 1</p> <p>Heating curve TEMP or R RISE</p> <p>Flow maximum and minimum temp. (PREmax, PREmin)</p> <p>Parameter frost protection mode (OTF, RTF)</p> <p>Menu Men</p> <p>MIXER (Room influence etc.) and PUMP (Switch-off conditions)</p>
--	--

$$A1 = (S4 > min1) \& (Heating = active)$$

If no room sensor is used, the room influence **RI** in menu **MIXER** must be set to zero and the sensor **S1** in the **SENSOR** menu set to **FIXED VALUE** (e.g. 20°C).

Program 0: Enabling of heating circuit pump **A1**, when the sensor **S4** has exceeded the minimum threshold **min1**. If the sensor **S4** is not used, then it must **not** be switched to **OFF**. To avoid the display "999" it is possible to allocate the sensor **S4** in the menu **SENSOR** a fixed temperature, which must be higher than **min1**.

All programs +1: As program 0 however the heating circuit pump **A1** is also enabled by sensor **S5** and minimum threshold **min2** (2 generators for the heating circuit).

$$A1 = ((S4 > min1) \text{ or } (S5 > min2)) \& (Heating = active)$$

All programs +2: As program 0 however output of the **set flow temperature** via the control output (e.g. for burner modulation).

SCALING: 0°C = 0.0 V
100°C = 10.0 V

Example: The set flow temperature 55°C is output at the control output as 5.5 volts.

If the pump is switched off due to one of the switch-off conditions (menu **PUMP**), then 0V is output to the control output. If switching off is because of condition **S4 < min1** then a voltage is output corresponding to the set flow temperature calculated by the controller.

In menu **COP1** in this program there are the following setting options:

OFS Offset value for set flow temperature, adjustment range -50°C ... +50°C, fs = 0

0-100 Output mode, 0-100 or 100-0, fs = 0-100

MIN Minimum output value (Adjustment range 0 ... 100), fs = 0

MAX Maximum output value (Adjustment range 0 ... 100), fs = 100

ACT Actual output value

TST Adjustable test value (adjustment range 0 ... 100). Calling **TST** leads automatically to manual mode. As soon as the value above the key ↓ (= Entry) flashes, the control output indicates the set values.

All programs +4: As program 0 however output of **mixer control** via the control output (for mixer with 0-10V control).

In menu **COP1** in this program there are the following setting options:

PRO Proportional part of the PID controller, fs = 5

INT Integral part of the PID controller, fs = 0

DIF Differential part of the PID controller, fs = 0

0-100 Output mode, 0-100 or 100-0, fs = 0-100

MIN Minimum output value (Adjustment range 0 ... 100), fs = 0

MAX Maximum output value (Adjustment range 0 ... 100), fs = 100

ACT Actual output value

TST Adjustable test value (adjustment range 0 ... 100). Calling **TST** leads automatically to manual mode. As soon as the value above the key ↓ (= Entry) flashes, the control output indicates the set values.

Note: Only one of the two auxiliary programs (" +2" or " +4") can be used.

Program 16: Release of **A1** and **A2** via **S4**, burner demand **A3**. With **active** heating, the load pump **A2** is switched off, once the set cylinder temperature **max1** is reached. Load pump **A2** continues running when the heating is **inactive** until the boiler minimum temperature **min1** or the difference **diff1** between T4 and T5 is undershot, so that the residual energy of the boiler is dissipated (independent of **max1**).

For **adjustable boiler operation without the mixer** it makes sense to set the threshold values **min1** and **min2** to **PREmin** and to activate the pump switch-off condition **PN < PM** in the **PUMP** menu.

A1 = S4 > min1 & (heating = active)

A2 = S4 > min1 & S4 > S5 + diff1 & (S5 < max1 or (heating = not active))

A3 = S4 < max2 and ((S5 < max1 & time prog.5) or ((S4 < min2 or S4 < NP + diff2) & (heating = active))

In this program, the switching mode of the values **diff2**↑ and **diff2**↓ functions in exactly the opposite way: the value **diff2**↓ in conjunction with the calculated set flow temperature gives the switch-on threshold and **diff2**↑ the switch-off threshold.

All programs +1: DHW cylinder priority – if **S5** is less than the threshold **max1** and the burner demand **A3** is enabled by **time program 5**, the heating pump **A1** is **disabled**.

A1 = S4 > min1 & (heating = active) & not (S5 < max1 & time program 5)

All programs +2: As program 16, however load pump function **only** in respect of **S5**, independent of the heating

A2 = S4 > min1 & S4 > S5 + diff1 & S5 < max1

All programs +4: As for program 16, however with output of a 0 – 10V voltage via the **control output 1 for burner modulation** as long as **A3** is active.

For activation of A3 via	Output value at control output 1
S5 < max1	max1 + 10.0 K + offset value OFS
Heating active and S4 < min2	min2 + offset value OFS
Heating active and S4 < NP + diff2	NP + diff2 + offset value OFS

Fixed scaling: 0°C = 0.0 V

 100°C = 10.0 V

Example: The output value 55°C is output at the control output as 5.5 volts.

With **A3** in operating condition **OFF** control output 1 is set to 0V.

In menu **COP1** in this program there are the following setting options:

OFS Offset value for output value, adjustment range -50K ... +50K, fs = 0

0-100 Output mode, 0-100 or 100-0, fs = 0-100

MIN Minimum output value (Adjustment range 0 ... 100), fs = 0

MAX Maximum output value (Adjustment range 0 ... 100), fs = 100

ACT Actual output value

TST Adjustable test value (adjustment range 0 ... 100). Calling **TST** leads automatically to manual mode. As soon as the value above the key ↓ (= Entry) flashes, the control output indicates the set values.

All programs +8: As program 16, but with output of the **mixer control via the control output 1** (for mixer with 0-10V input, together with the additional flow sensor **S3**).

In menu **COP1** in this program there are the following setting options:

PRO Proportional part of the PID controller, fs = 5

INT Integral part of the PID controller, fs = 0

DIF Differential part of the PID controller, fs = 0

0-100 Output mode, 0-100 or 100-0, fs = 0-100

MIN Minimum output value (Adjustment range 0 ... 100), fs = 0

MAX Maximum output value (Adjustment range 0 ... 100), fs = 100

ACT Actual output value

TST Adjustable test value (adjustment range 0 ... 100). Calling **TST** leads automatically to manual mode. As soon as the value above the key ↓ (= Entry) flashes, the control output indicates the set values.

Note: Only one of the two auxiliary programs (" +4" or " +8") can be used.

The **time program 5** is reserved for the hot water demand **A3** ($S5 < \max1$) (but still deactivated ex works). Only the time programs 1 to 4 are therefore available for the heating circuit.

Program 32: As **diagram 16**, including the possibility of selecting all the following programs (+1, +2, +4, +8) but with a second energy source with **S6** and **min2** for the release of the heating circuit pump **A1** (...and only for this!) and simple burner demand via **S6**. Here the **min2** threshold to **A3** is taken over by **max2**.

Load pump **A2** continues running when the heating is **inactive** until the boiler minimum temperature **min1** or the difference **diff1** between T4 and T5 is undershot, so that the residual energy of the boiler is dissipated (independent of **max1**).

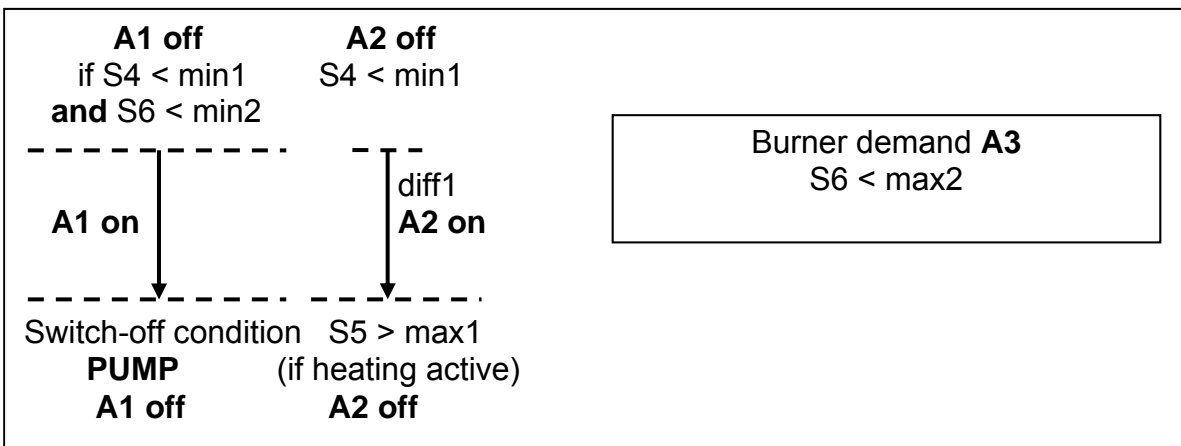

A1 = (S4 > min1 or S6 > min2) & (heating = active)

A2 = S4 > min1 & S4 > S5 + diff1 & (S5 < max1 or (heating = not active))

A3 = (S6 < max2)

Without time program for burner demand **A3**!

Program 48: As **diagram 16** including the possibility of selecting all the following programs (+1, +2, +4, +8) but **with second energy source with S6**. All conditions for **S4** also apply for **S6**. The higher temperature is effective (takes precedence) in all functions. Load pump **A2** continues running when the heating is **inactive** until the boiler minimum temperature **min1** or the difference **diff1** between T4 & T6 and T5 is undershot, so that the residual energy of the boiler is dissipated (independent of **max1**).

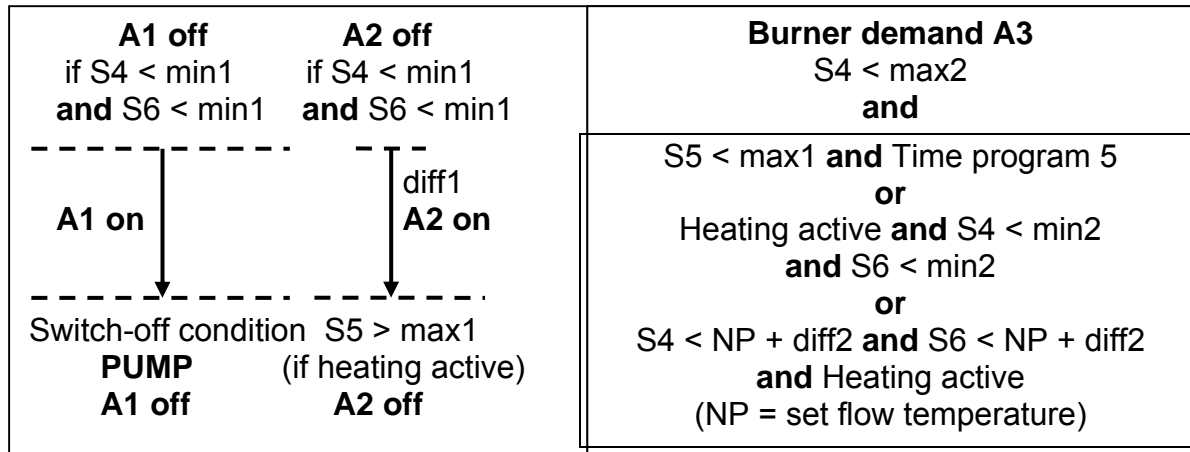

A1 = (S4 > min1 or S6 > min1) & (heating = active)

A2 = (S4 > min1 or S6 > min1) & (S4 > S5 + diff1 or S6 > S5 + diff1) & (S5 < max1 or (heating = not active))

A3 = S4 < max2 und ((S5 < max1 & Timeprogr.5) or ((S4 < min2 and S6 < min2) or (S4 < NP + diff2 and S6 < NP + diff2)) & (heating = active))

The **time program 5** is reserved for the hot water demand **A3** ($S5 < max1$) (but still deactivated ex works). Only the time programs 1 to 4 are therefore available for the heating circuit.

Diagram 64: Boiler circuit pump, mixer for return flow booster

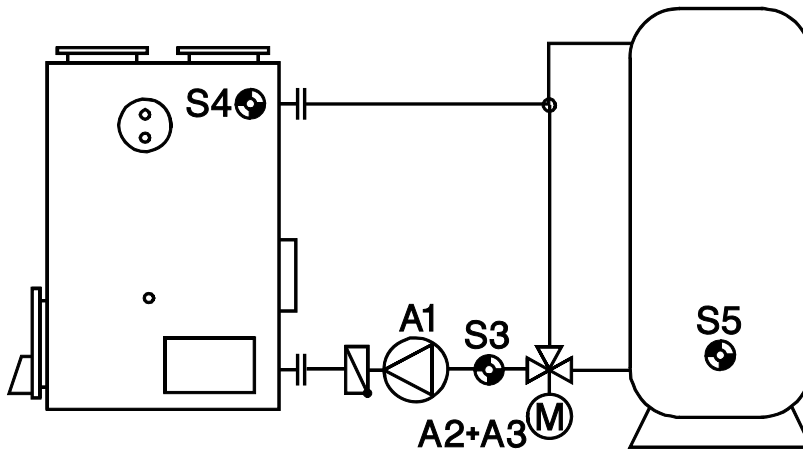

Program 64: Release of boiler circuit pump **A1**, if **S4** is greater than the threshold **min1** and **S4** is higher than **S5** by the difference **diff1** and **S5** has not exceeded the threshold **max1**.

<p style="text-align: center;">A1 off S4 < min1</p> <p style="text-align: center;">-----</p> <p style="text-align: center;">diff1 A1 on</p> <p style="text-align: center;">↓</p> <p style="text-align: center;">-----</p> <p style="text-align: center;">S5 > max1 A1 off</p>	<div style="border: 1px solid black; padding: 10px; margin: 10px auto; width: 80%;"> <p style="text-align: center;">Mixer control A2 / A3</p> <p style="text-align: center;">Fixed value FV at sensor S3 (fs = 60°C)</p> </div>
<p>Required settings:</p> <p>Basic control level</p> <p>Time</p> <p>Parameter menu</p> <p>Program number PR</p> <p>min1 ... Boiler S4 → A1 diff1 ... Boiler S4 – Cylinder S5 → A1</p> <p>max1 ... Cylinder S5 → A1 FV ... fixed value (value for return flow booster) in return line S3 → A2/3</p> <p>Menu Men</p> <p>MIXER (Mixer run time RT)</p> <p>All setting parameters necessary for return flow booster (program 64) are hidden in the menus!</p>	

$$A1 = S4 > min1 \ \& \ S4 > (S5 + diff1) \ \& \ S5 < max1$$

Program 65: As program 64, however with additional 10 V burner demand via **S6** and **S5** at control output 2

Additional required settings:

min3 ... COP2 on (10V) **S6** (fs = 40°C)

max3 ... COP2 off (0V) **S5** (fs = 65°C)

All setting parameters necessary for program 65 are hidden in the menus!

A1 = S4 > min1 & S4 > (S5 + diff1) & S5 < max1

Control output COP2: 10 V = S6 < min3 (burner on)

0 V = S5 > max3 (burner off)

In the menu **COP2** the function can be changed from "**NORMAL**" (=fs) to "**INVERSE**". In the "**INVERSE**" setting, 0 volts is output at the control output, if the threshold **min3** is undercut and 10V, if the threshold **max3** is exceeded.

Subsequently, an auxiliary relay can be connected to the control output **HIREL-STAG**, which forwards the burner demand in potential-free format.

Program 66: As program 64, however with additional 10 V burner demand via **S6** and **S2** at control output 2

Additional required settings:

min3 ... COP2 on (10V) **S6** (fs = 40°C)

max3 ... COP2 off (0V) **S2** (fs = 65°C)

All setting parameters necessary for program 66 are hidden in the menus!

A1 = S4 > min1 & S4 > (S5 + diff1) & S5 < max1

Control output COP2: 10 V = S6 < min3 (burner on)

0 V = S2 > max3 (burner off)

In the menu **COP2** the function can be changed from "**NORMAL**" (=fs) to "**INVERSE**". In the "**INVERSE**" setting, 0 volts is output at the control output, if the threshold **min3** is undercut and 10V, if the threshold **max3** is exceeded.

Subsequently, an auxiliary relay can be connected to the control output **HIREL-STAG**, which forwards the burner demand in potential-free format.

Scheme 80: Heating circuit, (automatic) boiler, cylinder, charging pump

Version 1: Automatic boiler, buffer cylinder, buffer charging pump

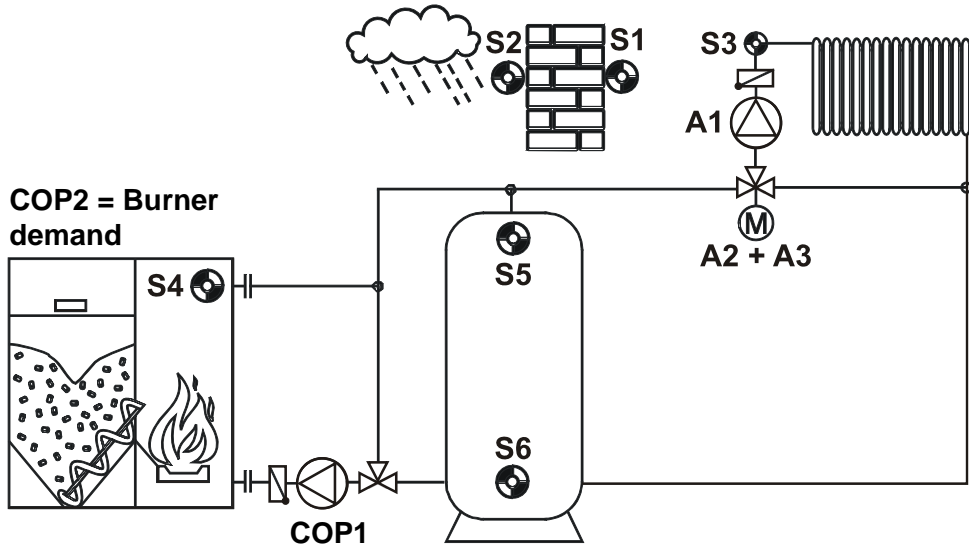

Program 80: Enabling of the heating circuit pump **A1** above the minimum thresholds. The load pump is switched on based on the temperature difference between boiler **S4** and buffer **S6** via the control output **COP 1**. The burner demand at the control output **COP 2** is activated either by a base temperature **min3** or **max3** or by undershooting of the set flow temperature **NP** plus the difference **diff2** at the buffer sensor **S5**. The burner demand is interrupted if the temperature at boiler sensor **S4** undershoots threshold **max2**.

<p>A1 off if $S4 < \text{min}1$ and $S5 < \text{min}2$</p> <p>-----</p> <p>A1 on</p> <p>-----</p> <p>Switch-off cond. PUMP A1 off</p>	<p>COP1 off $S4 < \text{min}1$</p> <p>-----</p> <p>diff1 COP1</p> <p>-----</p> <p>$S6 > \text{max}1$ COP1 off</p>	<p>Burner demand COP2 $S4 < \text{max}2$ and</p> <div style="border: 1px solid black; padding: 5px;"> <p>on $S5 < \text{min}3$ ($f_s = 40^\circ\text{C}$) off $S5 > \text{max}3$ ($f_s = 65^\circ\text{C}$) or heating active and $S5 < \text{NP} + \text{diff}2$ ($\text{NP} = \text{set flow temperature}$)</p> </div>
---	--	---

Required settings:

Basic control level: Time
 Operating mode (preferably **AUTO**) Set room temp. for lowering mode **RTL**
 Set Room temp. for normal operation **RTN** time programs for normal operation

Parameter menu: Program number **PR**

- min1**... Boiler **S4** → **A1** (heating circuit active), **COP1**
 - min2** ... Cylinder **S5** → **A1** (heating circuit active)
 - min3** ... Burner dem. on **S5** → **COP2**
 - max1** ... Cylinder **S6** → **COP1**
 - max2** ... Burner dem. **S4** → **COP2**
 - max3** ... Burner dem. off **S5** → **COP2**
 - diff1** ... Boiler **S4** – Tk. **S6** → **COP1**
 - diff2** ... Offset to set flow temp. **NP** → **COP2**
- Heat curve **TEMP** or **R RISE**
 Flow maximum and minimum temperature **PREmax**, **PREmin**)
 Parameter frost protection mode (**OTF**, **RTF**)

Menu Men

MIXER (Room influence etc.) and **PUMP** (Switch off conditions)

$A1 = ((S4 > min1) \text{ or } (S5 > min2)) \& (heating = active)$

$COP1\ 10V\ (on) = S4 > min1 \& S4 > (S6 + diff1) \& S6 < max1$

$COP2\ 10V\ (on) = S4 < max2 \& (S5 < min3 \text{ or } (S5 < (NP + diff2) \& heating = active))$

$COP2\ 0V\ (off) = S4 > max2 \text{ or } (S5 > max3 \text{ and } (S5 > (NP + diff2) \& heating = active))$

If no room sensor is used, the room influence in the menu **MIXER** must be set to **zero** and the sensor **S1** set to a **fixed value (e.g. 20°C)**.

The load pump and the burner demand are switched using 2 additional auxiliary relays **HIREL-STAG** (special accessories).

The auxiliary relay for the control output 1 (load pumps) must be installed in its own, suitable housing for space reasons and due to the separation low voltage/mains voltage.

If a **high efficiency pump** is to be switched with the auxiliary relay, due to the lower switching capacity, an **external** relay with sufficient switching capacity must be interposed.

If the burner demand is directly controlled via the burner modulation (no relay) then within the "COP2" menu, there is the possibility to set the mode of the control output from "NORMAL" to "INVERSE", so that the burner demand request occurs with output of 0V instead of 10V.

In this program, the switching mode of the values **diff2↑** and **diff2↓** functions in exactly the opposite way: the value **diff2↓** in conjunction with the calculated flow set temperature gives the switch-on threshold and **diff2↑** the switch-off threshold.

The following additional versions can also be achieved with program 80:

Version 2: Automatic boiler, buffer cylinder, DHW cylinder charging pump

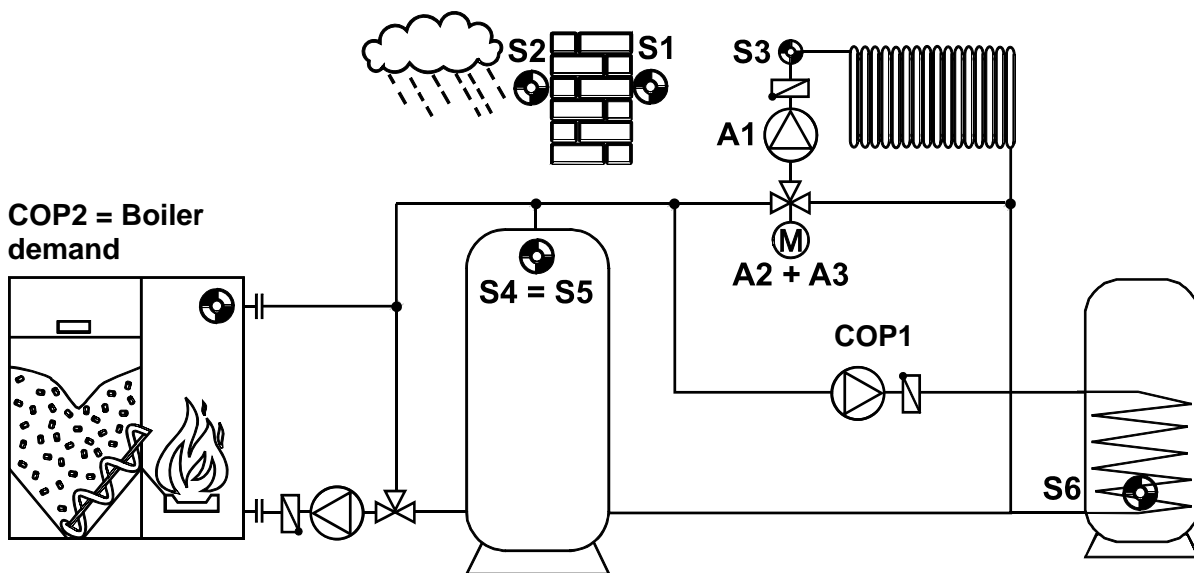

S4 = S5 Transfer of value from S5.
Instead of a measured value the input **S4** receives its (temperature) information from input **S5** (Menu SENSOR).

Version 3: Solid fuel boiler, buffer cylinder and DHW cylinder charging pump

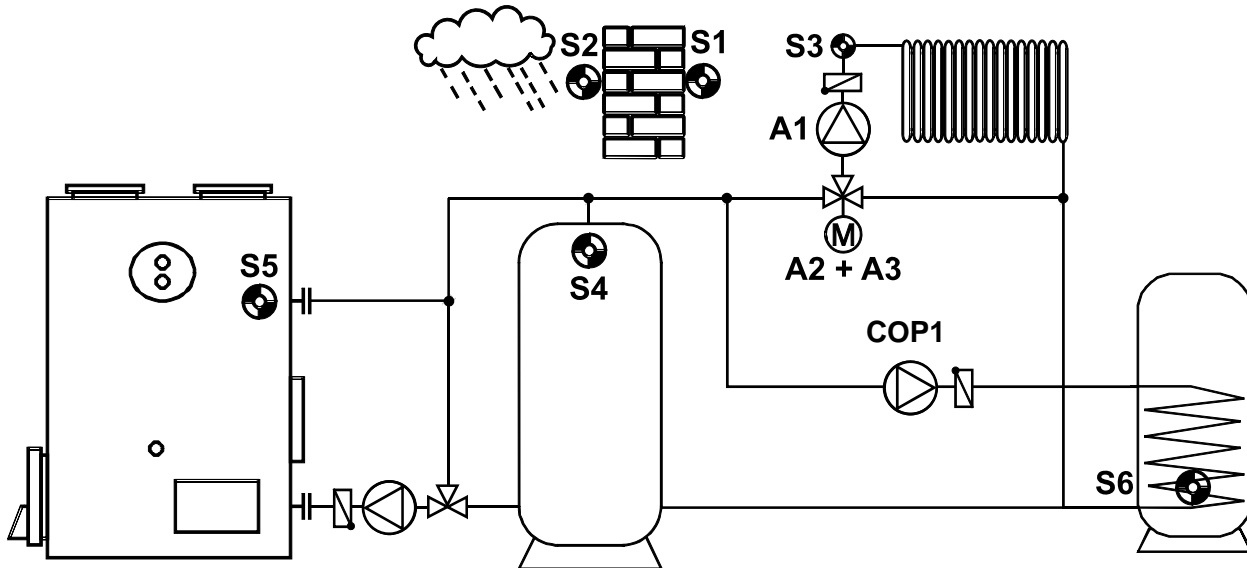

This version does not use control output 2 (COP2).

All programs +1: DHW cylinder priority – heating circuit pump A1 is blocked if S6 is lower than threshold max1.

Program 81 (80+1) (only recommended when using version 2 or 3):

$A1 = ((S4 > min1) \text{ or } (S5 > min2)) \& (\text{heating} = \text{active}) \& \underline{COP1 \text{ OFF}}$

Program 83 (=80+2+1):

$A1 = (\text{heating} = \text{active}) \& \underline{COP1 \text{ OFF}}$

All Programs +2:

The burner demand at control output **STAG 2** is enabled either if the threshold **min3** is undershot at DHW cylinder sensor **S6** or if the set flow temperature **SV** plus differential **diff2** is undershot at buffer sensor **S4**. The burner demand is interrupted if the temperature at boiler sensor **S5** overshoots threshold **max2**.

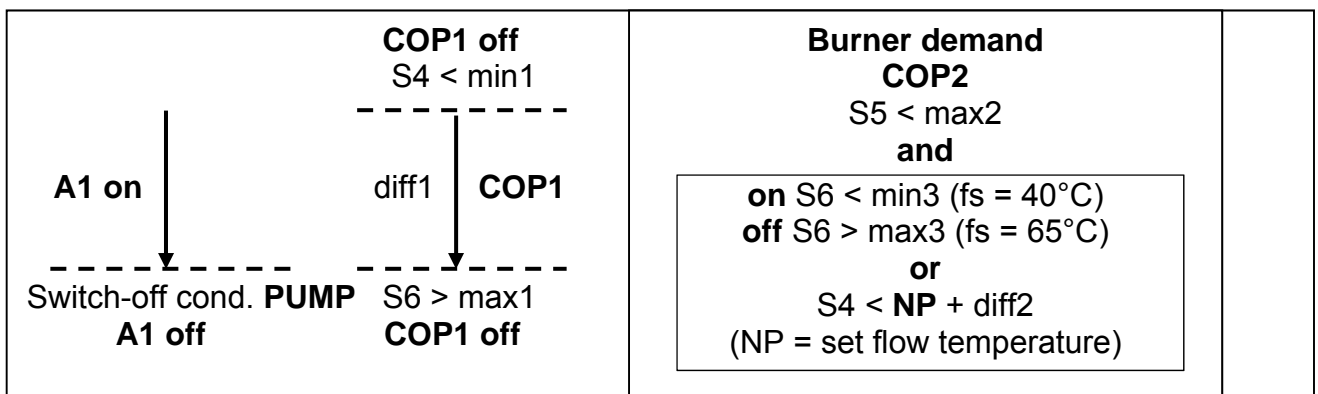
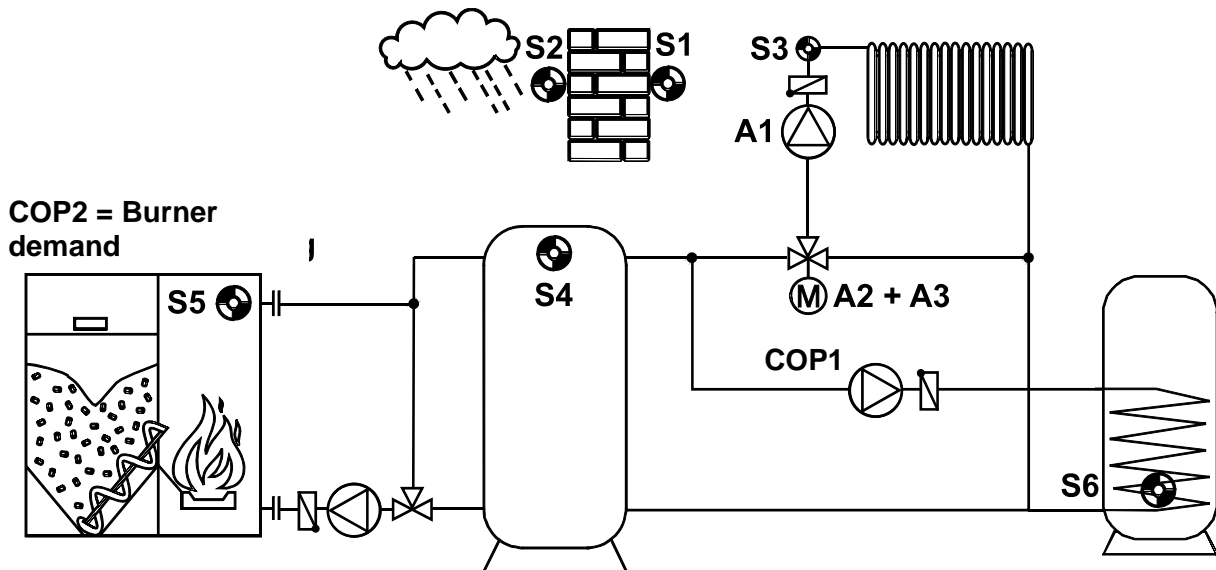

Required settings:

Basic control level:

Operating mode (preferably **AUTO**)
Set room temp. for normal operation

Time

Set room temp. for lowering mode **RTL**
RTN time programs for normal operation

Parameter menu: Program number **PR**

min1 ... Buffer **S4** → **COP1**

min3 ... Burner demand on **S6** → **COP2**

max1 ... DHW cylinder **S6** → **COP1**

max2 ... Burner demand off **S5** → **COP2**

max3 ... Burner demand off **S6** → **COP2**

diff1 ... Buffer **S4** – **CYL S6** → **COP1** **diff2** ... Offset to set flow temp. **NP** → **COP2**

Heat curve **TEMP** or **R RISE**

Flow maximum and minimum temperature **PREmax**, **PREmin**)

Parameter frost protection mode (**OTF**, **RTF**)

Menu **Men**

MIXER (Room influence etc.) and **PUMP** (Switch off conditions)

A1 = (heating = active)

COP1 10V (on) = S4 > min1 & S4 > (S6 + diff1) & S6 < max1

COP2 10V (on) = S5 < max2 & (S6 < min3 or (S4 < SV + diff2))

COP2 0V (off) = S5 > max2 or (S6 > max3 & (S4 > SV + diff2))

Program 96: Release of **A2** via **S4**, burner demand **A3**.

For **adjustable boiler operation without the mixer** it makes sense to set the threshold values **min1** and **min2** to **PREmin** and to activate the pump switch-off condition **PN < PM** in the **PUMP** menu.

A1 = Thermal mixer

A2 = S4 > min1 & (heating = active)

A3 = (S4 < min2 or S4 < NP + diff2) & heating = active

In this program, the switching mode of the values **diff2↑** and **diff2↓** functions in exactly the opposite way: the value **diff2↓** in conjunction with the calculated pre-run set temperature gives the switch-on threshold and **diff2↑** the switch-off threshold.

All programs +4: As for program 96, however with output of a 0 – 10V voltage via the **control output 1 for burner modulation** as long as **A3** is active.

For activation of A3 via	Output value
Heating active and S4 < min2	min2 + offset value OFS
Heating active and S4 < NP + diff2	NP + diff2 + offset value OFS

Fixed scaling: 0°C = 0.0 V

 100°C = 10.0 V

Example: The output value 55°C is output at the control output as 5.5 volts.

With **A3** in operating condition **OFF** control output 1 is set to 0V.

In menu **COP1** in this program there are the following setting options:

OFS Offset value for output value, adjustment range -50K ... +50K, fs = 0

0-100 Output mode, 0-100 or 100-0, fs = 0-100

MIN Minimum output value (Adjustment range 0 ... 100), fs = 0

MAX Maximum output value (Adjustment range 0 ... 100), fs = 100

ACT Actual output value

TST Adjustable test value (adjustment range 0 ... 100). Calling **TST** leads automatically to manual mode. As soon as the value above the key ↓ (= Entry) flashes, the control output indicates the set values.

If no room sensor is used, the room influence **RI** in the menu **MIXER** must be set to **zero** and the sensor **S1** set to a **fixed value (e.g. 20°C)**.

Program 112: Release of A2 and A3 via S4

With **active** heating, the load pump **A2** is switched off, once the set DHW cylinder temperature **max1** is reached.

Load pump **A2** continues running when the heating is **inactive** until the boiler minimum temperature **min1** or the difference **diff1** between T4 and T5 is undershot, so that the residual energy of the boiler is dissipated (independent of **max1**).

For **adjustable boiler operation without the mixer** it makes sense to set the threshold values **min1** to **PREmin** and to activate the pump switch-off condition **PN < PM** in the **PUMP** menu.

A1 = Thermal mixer

A2 = $S4 > min1$ & $S4 > S5 + diff1$ & ($S5 < max1$ or (heating = not active))

A3 = $S4 > min1$ & (heating = active)

All programs +1: DHW cylinder priority – if **S5** is less than the threshold **max1**, the heating pump **A3** is blocked.

A3 = $S4 > min1$ & (heating = active) & $S5 > max1$

All programs +2: As program 16, however load pump function **only in respect of **S5**, independent of the heating**

A2 = $S4 > min1$ & $S4 > S5 + diff1$ & $S5 < max1$

Diagram 128: Heating circuit with burner demand, switchover to cooling with cooler demand

The burner and the cooler demand are switched in a potential-free manner using 2 additional auxiliary relays **HIREL-STAG** (special accessories).

Sensors:

- S1 Room sensor RASPT or RAS
- S2 External sensor
- S3 Flow sensor
- S4 Sensor in the buffer cylinder, only all programs **+2**
- S5 External switchover heating/cooling operation, only all programs **+1**
- S6 external burner or cooler demand, dependent on the S5 switch state, only all programs **+1**

Outputs:

- A1 Pump
- A2 & A3 Mixer motor ON/OFF
- COP 1 Burner demand 0V = OFF, 10V = ON
- COP2 Cooler demand 0V = OFF, 10V = ON

Required settings:

Basic control level

Time

Parameter menu

Program number **PR**

Heat curve **TEMP** or **R RISE**

Flow maximum and minimum temperature **PREmax**, **PREmin**)

Parameter frost protection mode (**OTF**, **RTF**)

Set flow temperature for cooling operation **TNC** (fs = 18°C)

Menu *Men*





MIXER (Room influence etc.) and **PUMP** (Switch off conditions)

Program 128:

The cooling operation functions only in combination with the RASPT or RAS room sensor.

The operating mode is set using the room sensor with the aid of the slider switch:

Switchover between the various operating modes:

- **Heating** automatic mode 
- **Heating** normal mode 
- **Cooling** mode 
- Standby mode 
- Room temperature change by +/- 4°C (only possible in heating mode) 

Heating mode: Setting of the room sensor to "Automatic" or "Normal mode". The heating circuit pump **A1** and the burner demand via the **COP 1** control output are only switched off by the pump switch-off parameter (menu **PUMP**).

Cooling mode: Room sensor setting to "Cooling mode". The pump **A1** and the cooler demand via the **COP 2** control output are always active. The mixer control via the outputs **A2** and **A3** takes place **inversely** (mixer opened upon increasing temperature) and the set set temperature **TNC** (parameter menu).

All programs +1:

Like program 128, but the switchover does not take place via the slider switch of the room sensor rather via the external switch **S5** and the heating/cooling demands via the external switch **S6**.

In the **SENSOR** menu, the sensors **S5** and **S6** must be set to "**DIG**".

The digital sensor **S5** (external potential-free switching contact) determines whether heating or cooling operation is required. If the switch is set to "**ON**", then heating operation applies, if it is set to "**OFF**", then cooling operation applies.

Using digital sensor **S6** (external potential-free switching contact) in heating mode, the burner demand is activated via control output 1 while in cooling mode the cooler demand is activated via control output 2. If the switch is switched on, the demand is active.

The cooling operation functions only in combination with the RASPT or RAS room sensor.

All programs +2:

Like program 128, however a buffer cylinder sensor **S4** is used. This sensor delivers separate switching thresholds for the release of the pump and the burner or cooler demand.

Required settings:

Basic control level

Time

Parameter menu

Program number **PR**

min 1 ... Buffer **S4** → **A1** (if heating circuit active) WE = 45°C

min 2 ... Buffer **S4** → control output 2 for cooler demand WE = 65°C

max1 ... Buffer **S4** → control output 1 for burner demand WE = 75°C

max2 ... Buffer **S4** → **A1** (if RAS set to "Cooling mode") WE = 75°C

Heat curve **TEMP** or **R RISE**

Flow maximum and minimum temperature **PREmax**, **PREmin**)

Parameter frost protection mode (**OTF**, **RTF**)

Set flow temperature for cooling operation **TNC** (WE = 18°C)

Menu Men

MIXER (Room influence etc.) and **PUMP** (Switch off conditions)

Heating mode:

A1 = **S4 > min1 & (heating = active)**

COP 1 = **S4 < max1 & (heating = active)**

The set flow temperature is calculated according to the **heat curve**.

Cooling mode:

A1 = **S4 < max2 & (Room sensor = "Cooling mode")**

COP 2 = **S4 > min 2 & (Room sensor = "Cooling mode")**

The set flow temperature corresponds to the parameter value **TNC**.

Installation instructions

Sensor installation

Correct arrangement and installation of the sensors is extremely important for correct functioning of the system. It should be ascertained that the sensors are completely inserted in the immersion sleeves. The threaded cable connections can serve as strain relief. Fundamentally sensors should not be exposed to moisture (such as condensation) since this can diffuse through the cast resin and damage the sensor. If this happens, heating the sensor to 90°C for an hour might help. When using immersion sleeves in NIRO cylinders (innoxidable) or pools particular attention must be given to their **corrosion resistance**.

- **Boiler sensor (boiler flow):** This sensor is either screwed into the boiler using an immersion sleeve or attached to the flow line at a short distance to the boiler (see also "clip-on sensors").
- **Buffer sensor:** It is recommended to install the sensor in the upper part of the cylinder as a reference sensor using the immersion sleeve supplied. The best position as reference sensor for the load pump between the boiler and buffer is just above the return outlet. For cylinders without a screw-in facility for the immersion sleeve the sensor can be inserted under the insulation against the wall of the cylinder if necessary. In this case attention should be paid to achieving a long-term secure seating (e.g. cable fastening).
- **Clip-on sensor:** Optimally secured using roll springs, pipe clamps or hose band clips to the line. Make sure the material used is suitable (corrosion, temperature resistance, etc.). Finally the sensor must be well insulated so that the exact pipe temperature is recorded without being influenced by the ambient temperature.
- **Outdoor temperature sensor:** This sensor is installed on the coldest wall (usually the north side) approx. one to two meters above ground level. Temperature influences from nearby air shafts, open windows, etc. are to be avoided.

Sensor lines

All of the sensor lines with a cross-section of 0.5mm² can be extended up to 50m. With this length of line and a Pt1000 temperature sensor, the measurement error is approx. +1K. Longer lines or a lower measurement error require an appropriately larger cross-section. The sensor and the probe can be connected by putting the heat-shrinkable sleeve truncated to 4 cm over a wire and twisting the bare ends. If one of the wire ends is tinned then the connection must be made through soldering. Then the heat-shrinkable sleeve is put over the bare, twisted ends and carefully heated (such as with a lighter) until it has wrapped the connection tightly.

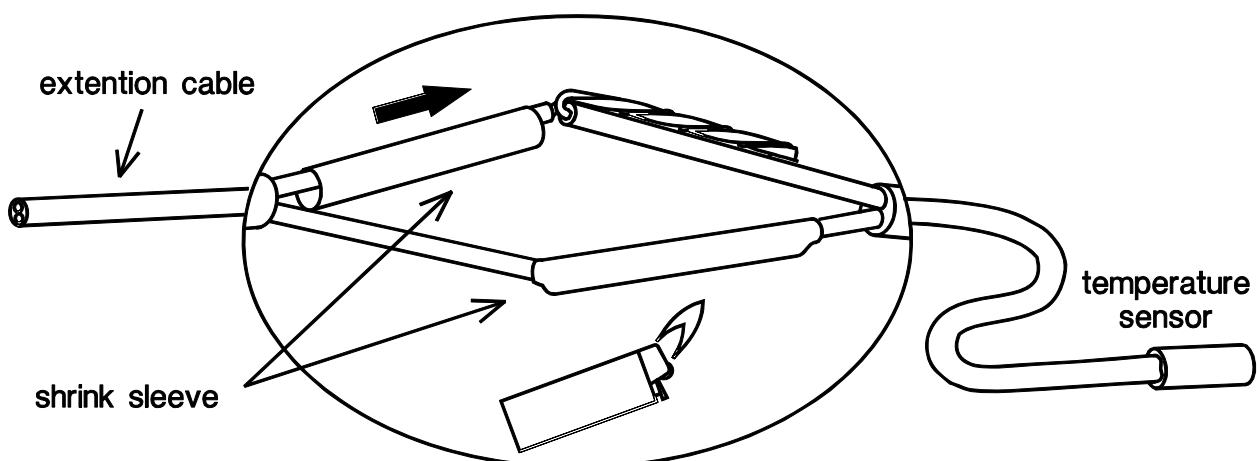

In order to prevent measurement fluctuations, the sensor cables must not be subject to negative external influences to ensure fault-free signal transmission. When using non-screened cables, sensor cables and 230V network cables must be laid in separate cable channels and at a minimum distance of 5 cm. If screened cables are used, the screen must be connected to the sensor earth.

Installing the device

WARNING! Always pull the mains plug before opening the casing!

Only work inside the controller with the power cable disconnected.

Unscrew the screws on the top of the case and lift the cover. The control electronics are in the cover. The connection to the terminals in the lower case is made by contact pins when the cover is later replaced. The body of the case can be screwed securely to the wall through the two holes using the fastening materials provided (**with the cable glands downwards**).

Electrical connection

Warning: Electrical connection may only be carried out by a technician according to the pertinent local regulations. The sensor lines must not be laid in the same cable channel as the supply voltage. The maximum load of output A1 equals 1.5A while that of outputs A2 and A3 each equals 2.5A! All outputs are fused together with the device itself with 3.15A. Increasing the fuse protection to max. 5A (medium time lag) is permitted. The appropriate strip terminal **PE** is to be used for all protective conductors.

Notice: The system has to be grounded properly and furnished with surge arresters to protect it from damage due to lightning. Sensor failures due to storms and static electricity are usually the result of faulty construction.

All sensor grounds \oplus are interconnected and fully interchangeable.

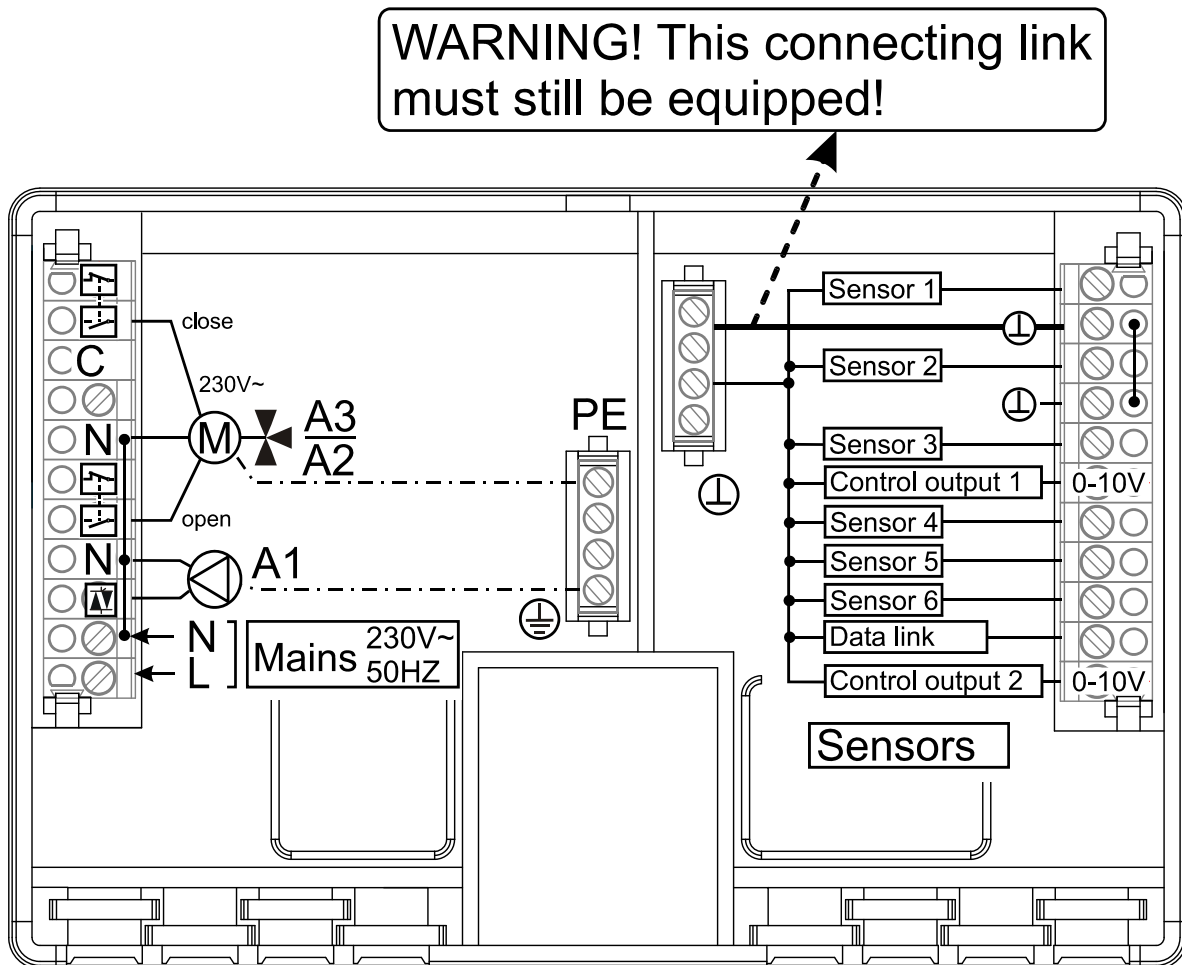

Special connections

Control output (0 to 10V / PWM)

These outputs are intended for the speed control of electronic pumps, to control the burner output for switching tasks with the relay HIREL-STAG in certain programs. They can be operated via respective menu functions parallel to the outputs A1 to A3.

Sensor input S6

As described in the menu SENSOR all six inputs have the possibility to operate as a digital input. Compared to the other inputs S6 has the special feature of being able to record fast signal changes of the type supplied by volume flow encoders (type VSG...).

The data line (DL-Bus)

The bi-directional data link (DL-Bus) was developed for the ESR/UVR series and is only compatible with products of the Technische Alternative company. Any cable with a cross section of 0.75 mm² can be used for the data link (e.g. twin-strand) having a max. length of 30 m. For longer cables, we recommend the use of shielded cable. If screened cables are used, the screen must be connected to the sensor earth

Interface to PC: The data is cached via the data converter **D-LOGG**, Bootloader **BL-NET** or **C.M.I.** interface and transferred to the PC on request. **BL-NET** and **C.M.I.** require a separate 12V power unit for power supply

External sensors: Reading the values from external sensors with DL connector.

Switch output 3 to potential-free

By removing the jumper **J** the relay output A3 can be made potential-free.

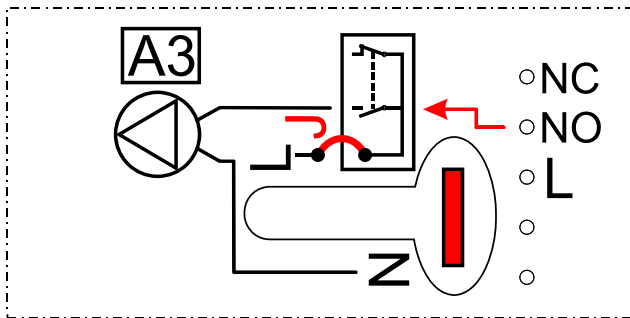

With the jumper **J** in place, output 3 is **not** potential-free.

Example: Connection of a pump

L ... phase conductor
 NO Closer (make contact)
 NC Opener (break contact)

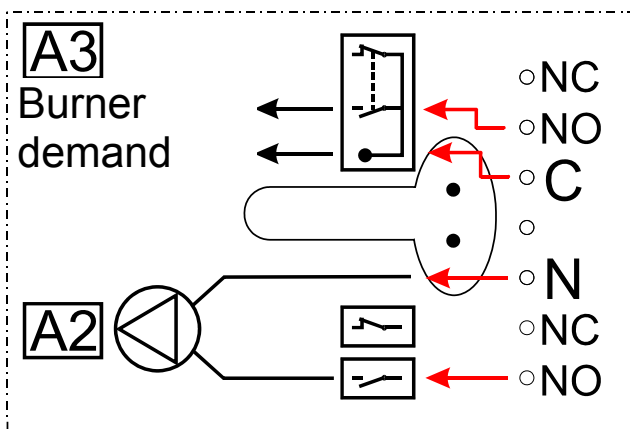

If the jumper is removed, then output 3 is potential-free.

Example: Diagram 16
 Burner demand A3 + Pump A2

C Root C
 NO Closer (make contact)
 NC Opener (break contact)

Operation

The large display contains the symbols for all important information and a plaintext area. Navigation with the coordinate keys is matched to the display sequence.

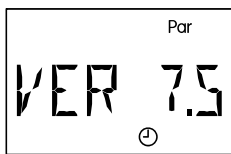
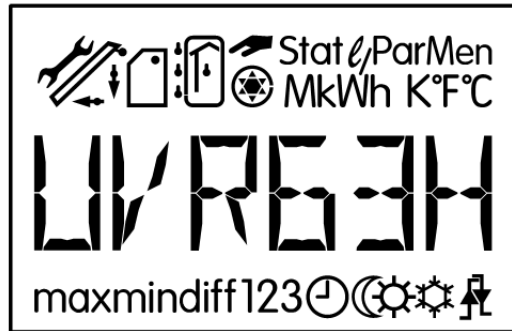

All display segments are momentarily displayed when the device is started up. Subsequently the type designation and version number are displayed (important for support queries).

The ex factory default setting is loaded by pressing the key during plugging in.

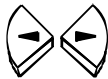

Navigation keys within a level and for changing parameters.



Entry to a menu, release of a value for changing with the navigation keys (enter key).



Return from the last menu level selected, exit the parameterizing of a value (return key).

To the side of the display, the currently active outputs are identifiable on the green illuminated figures 1 - 3. If the speed control is active, the output 1 display flashes according to the speed stage.



Change a value (parameter)

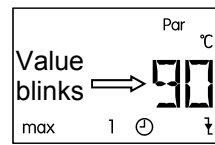
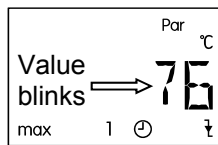
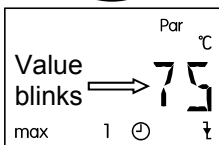
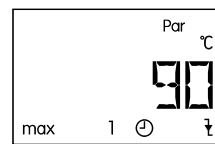
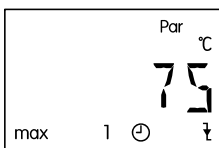

When a value is to be changed the arrow key must be pressed in a downward direction. This value now blinks and can be changed using the navigation keys. By pressing the arrow key in an upward direction it is saved.

The basic control level

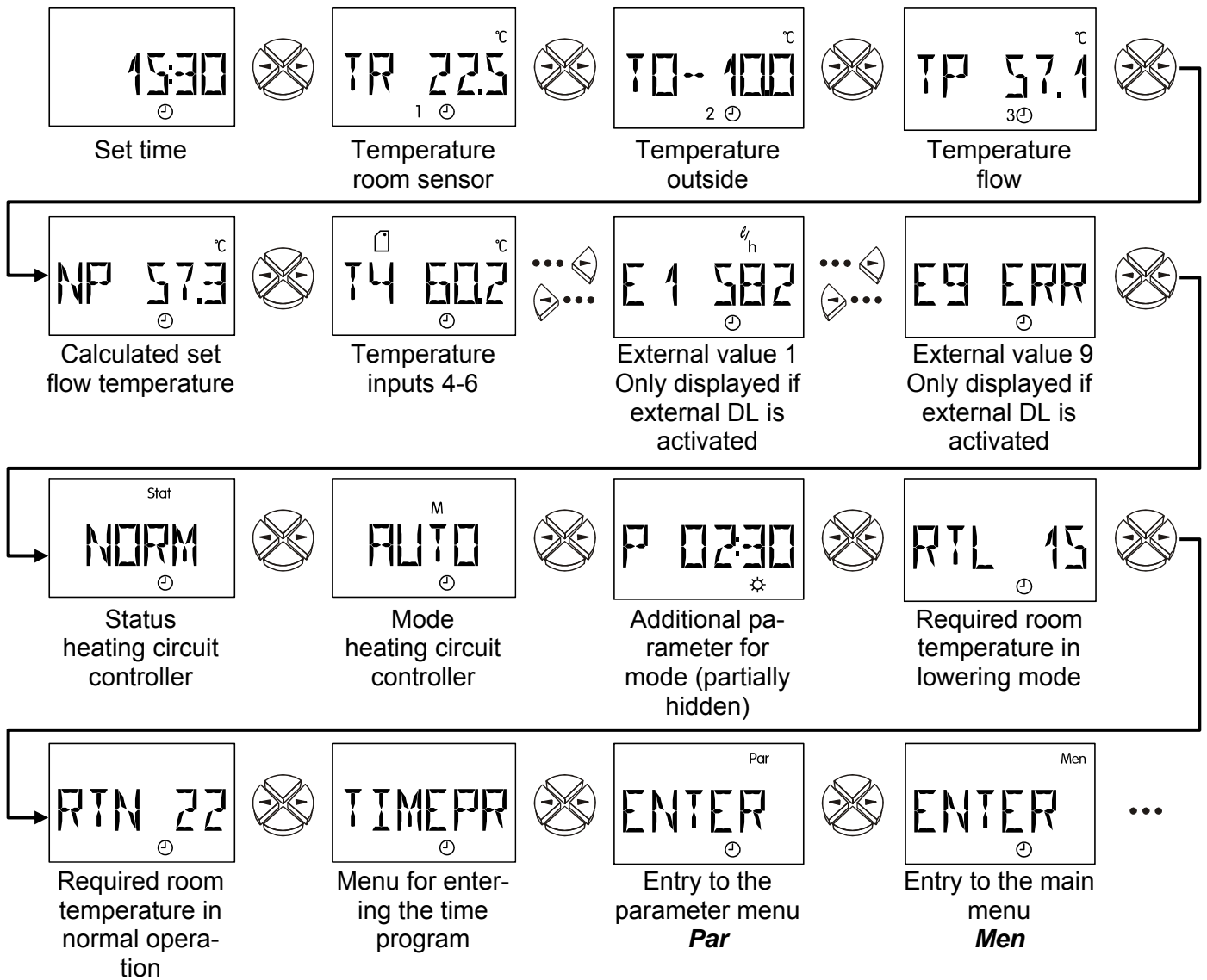

15.30 Set time.

The time is set by pressing enter ↓ and the navigation keys ←→. Press the key again to switch between minutes and hours.

Power reserve in the event of a power failure: at least 1 day, typically 3 days.

TR Temperature room sensor. If the room sensor RPT or RAS is used then it is important that the type is set to S1 RPT (or S1 RAS) in the sensor menu. Only then can the position of the room sensor switch (operating mode) be processed correctly. **Notice** of an incorrectly set type of sensor: The correct temperature is only displayed in automatic operation. Other switch settings display excessive temperature values (Factory settings fs = RPT).

TO Outdoor temperature. The set flow temperature is calculated using the outdoor temperature and on the basis of the heat curve.

TP Flow temperature. In the ideal case the measured value exactly matches the set value NP. If TP is less than NP the mixer is opened, if TP is greater than NP the mixer is closed.

NP	Calculated set flow temperature. The set flow value is calculated on the basis of the heating curve, the outdoor temperature recorded and where appropriate taking the influence of a room sensor into account. The heating circuit controller attempts to reach this temperature at the flow sensor TP through mixer OPEN/CLOSE.
T4-6	Allocation of the sensor inputs S4 to S6 is dependent on the program. T4, T5 and T6 therefore indicate the actual measured temperature as long as the inputs have been allocated.
NORM Stat	Status display of the heating circuit controller with the possible displays: NORM – normal operation, LOW – lowering mode, STB – standby mode MALF – malfunction, FRO – frost protection mode, STAT – display for programs 64 – 66, COOL – Cooling operation for programs 128 – 131. Additionally the lower display area contains the symbol-based Status display.
PARTY	Operating mode of the heating circuit controller. Capable of being set with the arrow keys are: AUTO – automatic operation NORMAL – permanent control of the room temperature set for normal operation LOWER – permanent control of the room temperature set for lowering mode PARTY – heating is carried out up to a pre-set time P XX.XX LEAVE – from the current date up to the date MXX XX 24:00 the controller operates only in lowering mode HOLID(AY) – public holiday mode; from the current day the controller takes over the Saturday heating times until the date MXX XX and for this date the Sunday heating times STB (Standby) – the control function is switched off; the frost protection function is activated For the modes of operation PARTY , LEAVE and HOLID the controller switches back to automatic operation after the time indicated has expired.
P 02.30	Additional parameter for mode: party, holiday or leave. Here the time for party mode (in example up to 2:30 AM) or the date set for leave and holiday modes.
RTL	Required room temperature for lowering mode . Set value for the room temperature outside the time window. If no time program is setup, then RTL is used as the set value. (fs = 15°C), setting range 0 to 30°C
RTN	Required room temperature in normal operation . This value is used as the set value for the room if the time program does not specify a different one (fs = 22°C), setting range 0 to 30°C.
TIMEPR	Entry to the time programs menu
ENTER <i>Par</i>	Entry to the parameters menu
ENTER <i>Men</i>	Entry to the main menu

Optional displays in the basic control level

These displays appear between display T6 and STATUS if the appropriate functions (speed control, control output and/or heat quantity counter) are activated.

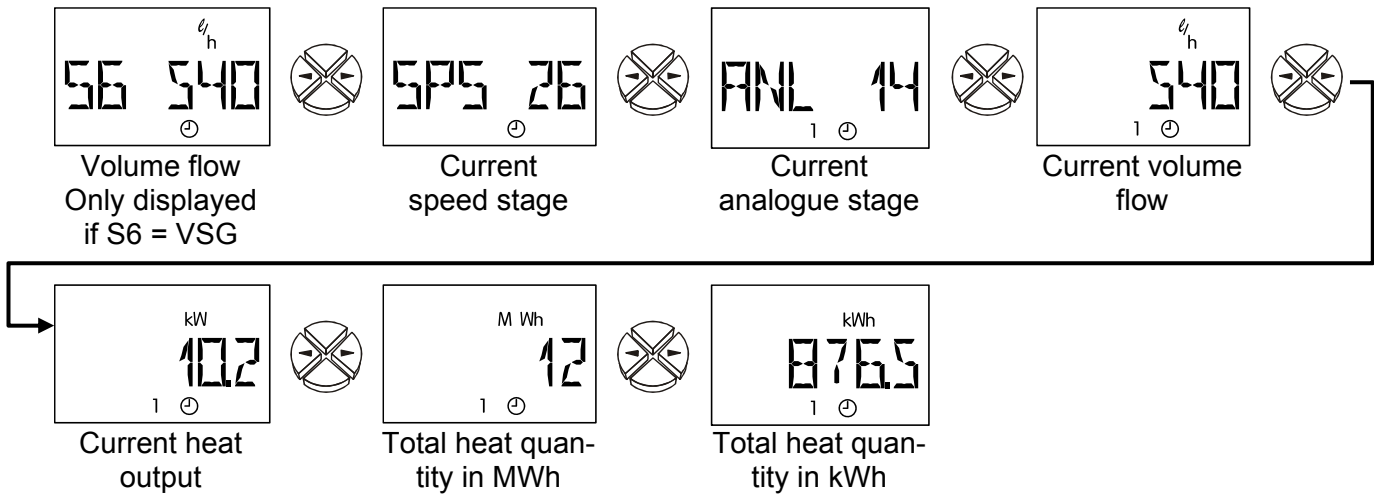

S6 Volume flow, shows the flow rate of the volume flow encoder in litres per hour

SPS Current speed stage (example 14). This display is only shown when the speed control is activated.

Display range: 0 = output is switched off
30 = speed control runs at highest level

ANL Current analogue stage; is displayed only if the control output is activated.

Display range: 0 = output voltage = 0V or 0% (PWM)
100 = output voltage = 10V or 100% (PWM)

l/h Current volume flow (heat quantity meter 1-3) used to calculate the heat quantity. Displays the flow rate of the volume flow encoder or the fixed volume flow in litres per hour.

kW Momentary determined performance (heat quantity counter 1-3). This value is calculated from the flow temperature, return temperature and volume flow in the heat quantity counter.

kWh/MWh Total heat quantity since start-up or last reset (heat quantity meter 1-3).

The menu items **l/h**, **kW** and **kWh/MWh** are only displayed when at least one heat quantity meter has been activated.

The status display

This menu displays the status of the heating circuit. For example, it can be seen which switch off condition is currently responsible for switching off the heating pump. The switch-off conditions are set in submenu **PUMP** in the **ENTER/Men** menu.

If the condition results in switching off the heating circuit the symbol  is shown in the lowest display line. In the following example the calculated flow temperature has fallen below the minimum temperature **PREmin** and the switch-off condition **PN<PM** is activated:

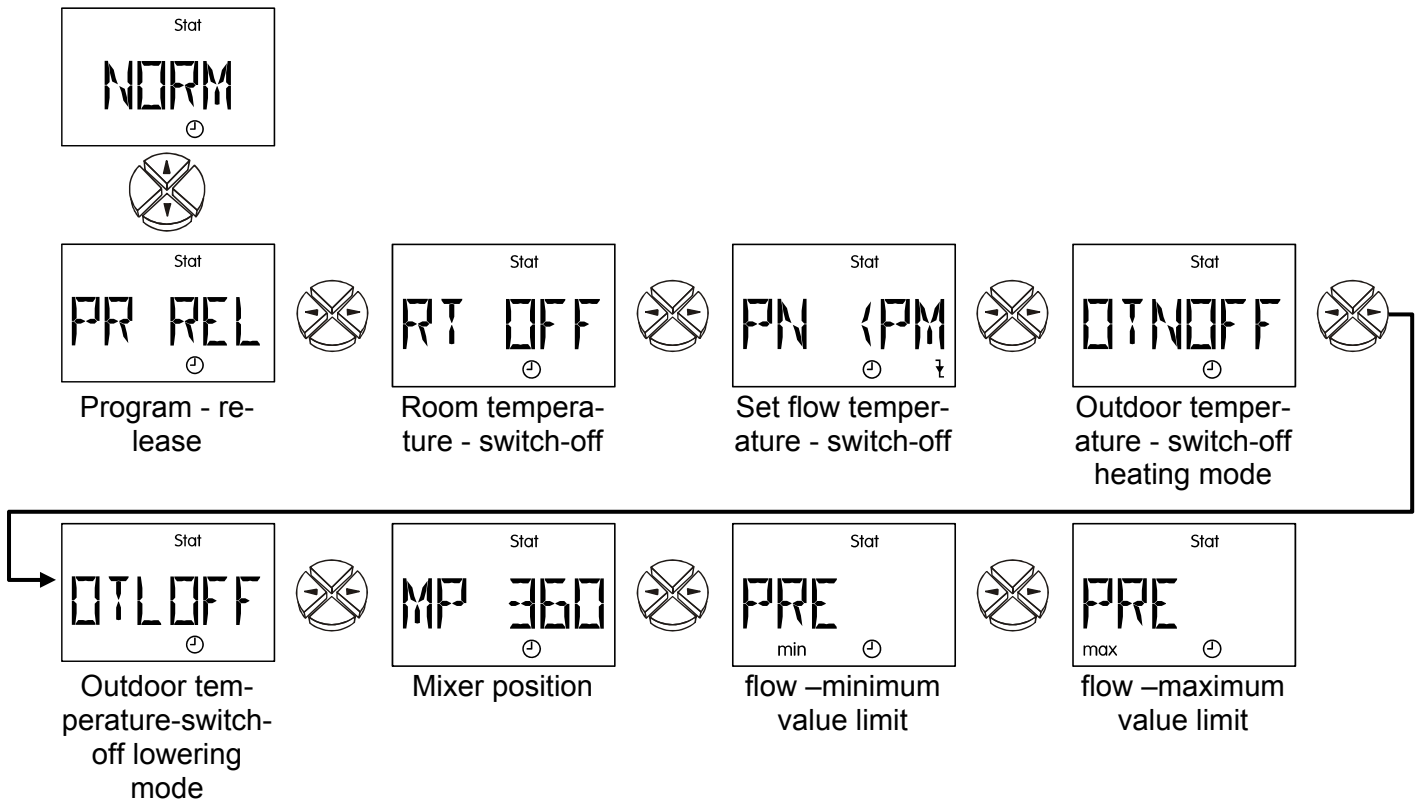

The above-mentioned displays mean:

PR REL The minimum threshold has been exceeded (= minimum temperature boiler reached)

RT OFF The room temperature switch-off is not activated

PN < PM The calculated set flow temperature has fallen below the flow minimum temperature therefore pump switch-off (symbol  in the lower display line)

OTNOFF The outdoor temperature switch-off is not activated in normal operation

OTLOFF The outdoor temperature switch-off is not activated in normal operation

MP 360 Mixer position (remaining run time in seconds)

PRE min The calculated flow temperature has fallen below the minimum allowable temperature (setting in *Par* menu). The display of the symbol  means that the actual flow temperature is limited by the minimum value.

PRE max The calculated flow temperature has not exceeded the permitted temperature (setting in *Par* menu). If the symbol  is displayed the actual flow temperature is limited by this maximum value.

The display **MALF** (malfunction) in the status display means that the external sensor is defective (unrealistic, high or low values, short circuit or interruption). In the event of a fault, the controller calculates the set flow temperature **NP** for an outdoor temperature of 0°C.

The time program menu

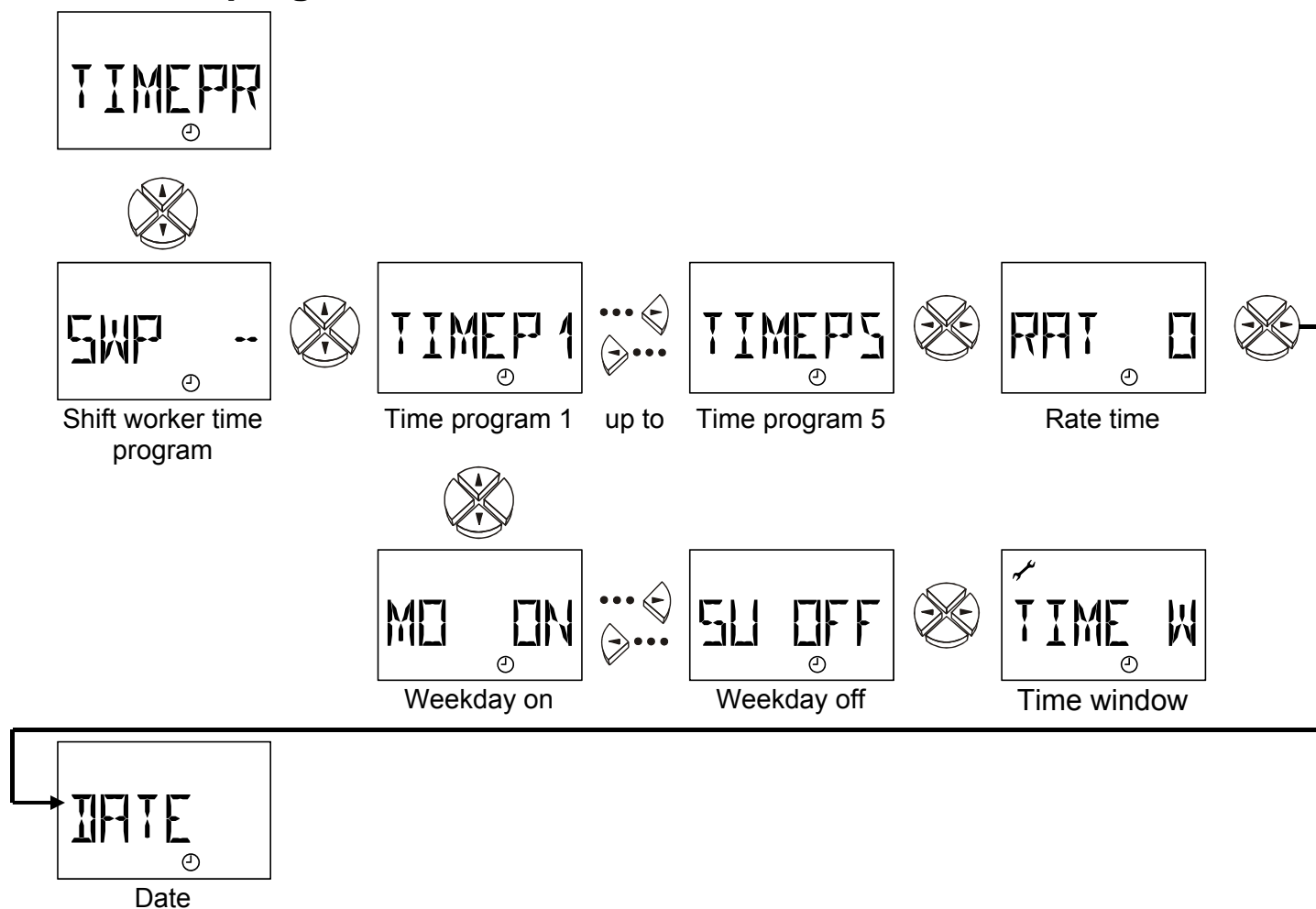

In this menu a shift worker time program, up to 5 time programs (P1-P5), a rate time and the date can be configured.

For every time program 3 windows with the possible allocation of a set value (**NV**) are available. During the switch-on times the heating mode with the allocated set values applies for the heating circuit. If no individual set values are assigned **RTN** (= room temperature in normal operation) is used. Outside the time programs (lowering mode) **RTL** (= room temperature in lowering mode) applies as set value. If no time program is set, then **RTL** is used as the set value. **RTN** and **RTL** are adjustable in the basic control level. Every time program can be assigned to any weekdays.

Shift worker time program **SWP** (from version 1.7):

With this it is possible to create several time programs with differing heating periods and to specifically enable time windows simply by setting the parameters **SWP**.

- SWP = --** All 5 time programs are used for the heating
- SWP = 1** Currently only time program 1 is permitted for the heating
- SWP = 15** Currently only the time programs 1 and 5 are permitted for the heating.
Adjustment range: SWP 15 to SWP 45

Application example: For a combination of time program **TIMEP1** with **TIMEP5** (setting: **SWP 15**) **TIMEP1** is the time program during shift work and **TIMEP5** the program for the weekend.

TIMEPx Selection of time programs 1 to 5 and entry with the lower arrow key

MO By setting ON and OFF for each day it is determined whether on this day until **SU** the time program is activated.

TIME W Entry with the lower arrow key after which the switch-on and switch-off times for the time window 1 can be entered.

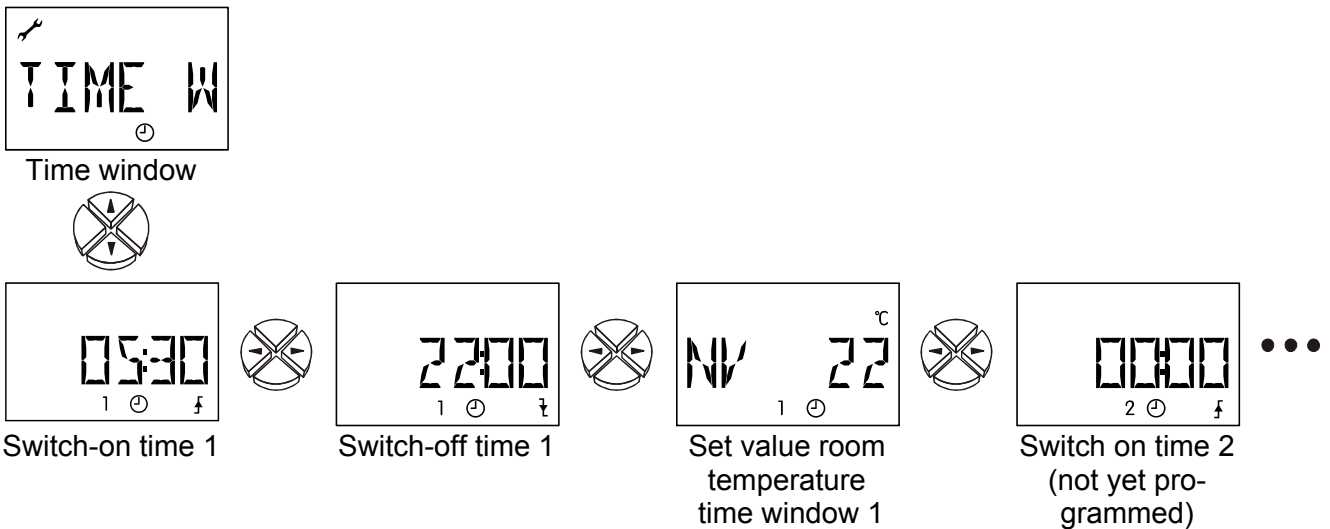

NV Set room temperature value for time window 1
 NV -- = no set value for the time window; **RTN** is used.

The time windows 2 and 3 can be set in the same way; the appropriate digits are shown in the lower line of the display.

RAT Rate time in minutes. Adjusts the switch-on point fixed in the time window according to outdoor temperature. This entry refers to an outdoor temperature of -10°C and is 0 at plus 20°C. For example, if the rate time is 30 minutes and the outdoor temperature is 0°C, the system will switch on 20 minutes earlier under normal operation. Adjustment range 0-255 min

Date setting **DATE**

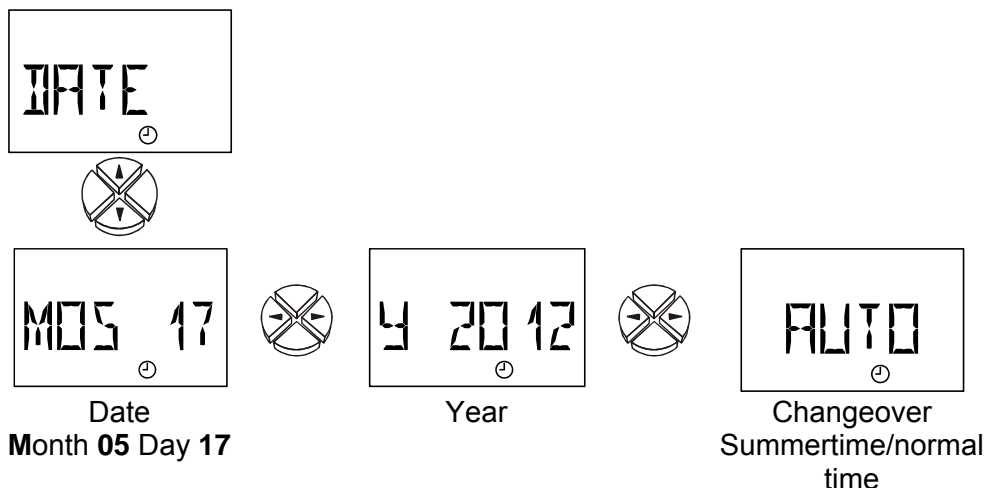

M05 17 Setting of month and day. Change between month and day using the downward arrow key. Select with the lateral arrow key and confirm with upward arrow.

Y 2012 Setting the year

AUTO Automatic changeover from normal to summertime. With the selection **NORMAL** fixed setting of the normal time is made.

The parameter menu *Par*

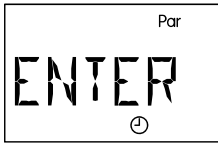

In the following example the **Par** menu has been selected for program 16 so that all setting parameters (max, min, diff) can be displayed.

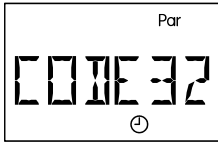

Access code

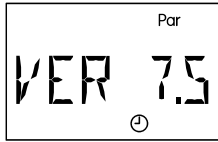

Software version

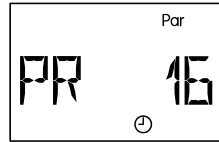

Program number

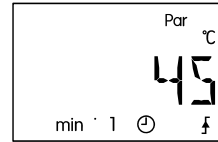

Min. temp. 1 switch-on value (2 times)

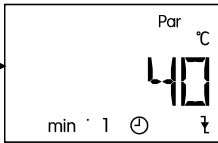

Min. temp. 1 switch-off value (2 times)

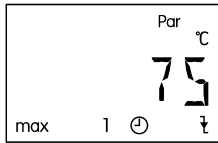

Max. limit 1 switch-off threshold

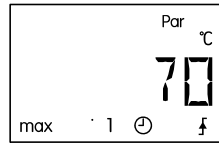

Max. limit 1 switch-on threshold

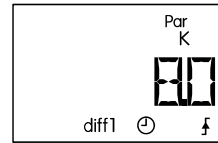

Differential 1 switch-on threshold (2 times)

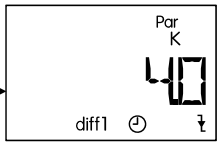

Diff. 1 switch-off threshold (2 times)

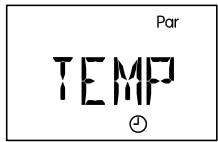

Setting method temperature

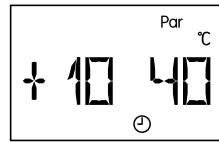

Set flow temp. at +10°C

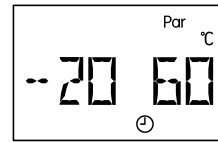

Set flow temp. at -20°C

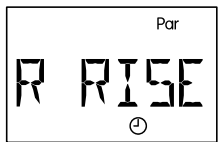

Setting method rate of rise

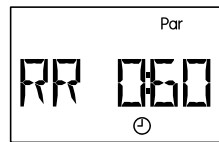

Rate of rise acc. to diagram

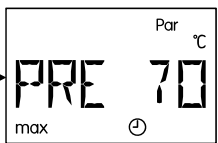

Maximum allowable flow temp.

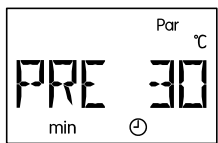

Minimum allowable flow temp.

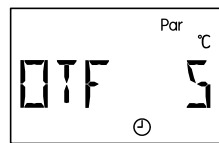

Outdoor temperature threshold frost protection mode

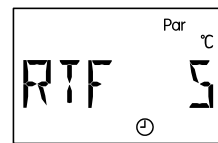

Room temperature at frost protection mode

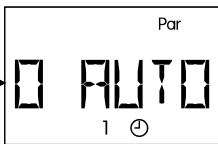

Output 1 automatic/manual mode

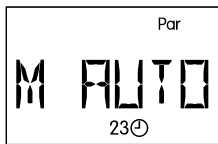

Output 2 + 3 automatic/manual mode

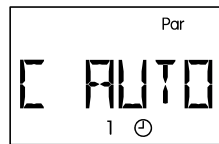

Automatic/manual mode (2 times) for the control outputs

- CODE** The other menu items of the parameter menu are displayed only after the correct code (**code 32**) has been entered.
- VER** Indicates software version. As indication of the intelligence of the device cannot be altered and must be specified with every query.
- PR** Program selection according to the selected hydraulic diagram ($fs = 0$)
 Further functions can be added to the described programs. The described functions apply together. "All programs +1 (+2, +4, +8)" indicates that the selected program number can be increased by the sum total of these numbers.
Example: Program 0 +1 + 2 = program number 3 = two generators and output of the set feed temperature to the control output.
- min ↑** From this temperature at the sensor the output is enabled. ($fs_1 = 45^\circ\text{C}$, $fs_2 = 65^\circ\text{C}$, $fs_3 = 40^\circ\text{C}$)
- min ↓** The previously via **min ↑** enabled output is disabled again from this temperature. **min** prevents boiler sooting. Recommendation: The switch-on point should be selected 3 to 5K higher than the switch-off point. The software does not allow a differential less than 1K. ($fs_1 = 40^\circ\text{C}$, $fs_2 = 60^\circ\text{C}$)
 Setting range: -20 to 150°C in 1°C increments (applies to both thresholds, **min↑** must however be at least 1K greater than **min↓**)
- max↓** Maximum limit – switch-off threshold ($fs_1 = fs_2 = 75^\circ\text{C}$, $fs_3 = 65^\circ\text{C}$)
- max↑** Maximum limit – switch-on threshold ($fs_1 = fs_2 = 70^\circ\text{C}$)
 Setting range: -20 to 150°C in increments of 1°C (for both thresholds, but **max↓** has to be at least 1K greater than **max↑**)
- diff↑** Differential – switch-on threshold ($fs = 8\text{K}$)
- diff↓** Differential – switch-on threshold ($fs = 4\text{K}$)
 Setting range: 0.0 to 9.9K in increments of 0.1K
 10 to 99K in increments of 1K (for both thresholds, but **diff↑** has to be at least 0.1K / 1K greater than **diff↓**)

Setting method heat curve *TEMP / R RISE*

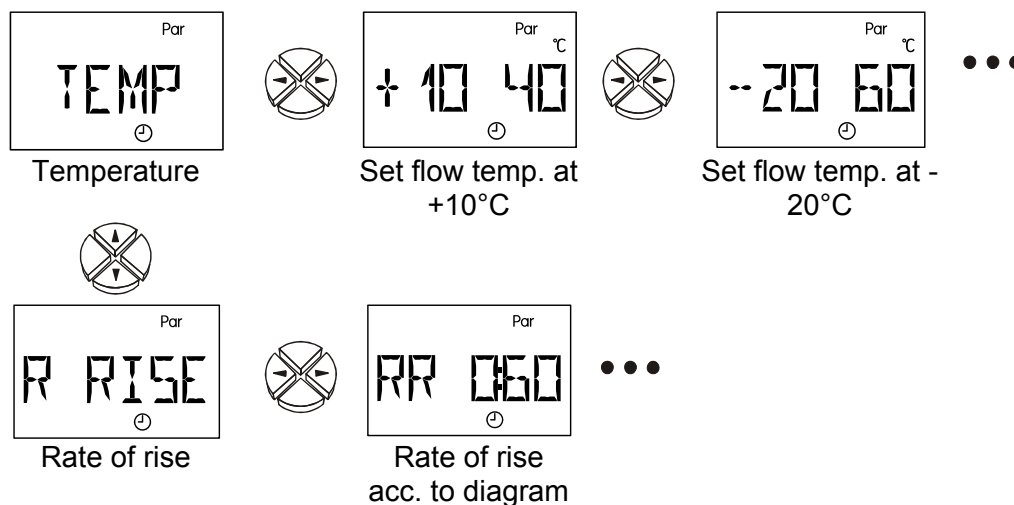

The flow temperature is usually calculated from the outdoor temperature and the heating curve (Setting: menu **MIXER**, type of control: **OT CON**). The heat curves are calculated for a set room temperature of +20°C and are correspondingly shifted in a parallel direction for other set room temperatures using the set room temperature influence.

An exception is the fixed value control (Setting: menu **MIXER**, type of control: **FV CON**). The flow is set in **lowering mode** to the listed temperature of +10°C and in **heating mode** to that of -20°C.

TEMP Parameterizing the heat curve via the correlation of outdoor temperature (at +10°C and -20°C) to flow temperature. Here, another reference point is set at +20°C outdoor temperature = +20° flow temperature. The values for +10°C and -20°C are to be allocated in the next display windows (fs +10 = 40°C, fs -20 = 60°C).

R RISE Parameterizing the heat curve via the rate of rise as is common with many heating controllers. For this purpose in the next window RR the rate of rise is to be selected according to the diagram (fs=0.60).

In both of these methods, the influence of the outdoor temperature on the flow temperature is not linear. Via the parameterizing mode "Rate of rise" the curvature is set according to the standard. Via the parameterizing mode "Temperature" designation of the set flow temperature creates a "bending of the heat curve". By this means the differing heat emissions of various heating systems (under floor, wall heating, radiators, etc.) are allowed for.

Heat Curve "Temperature"

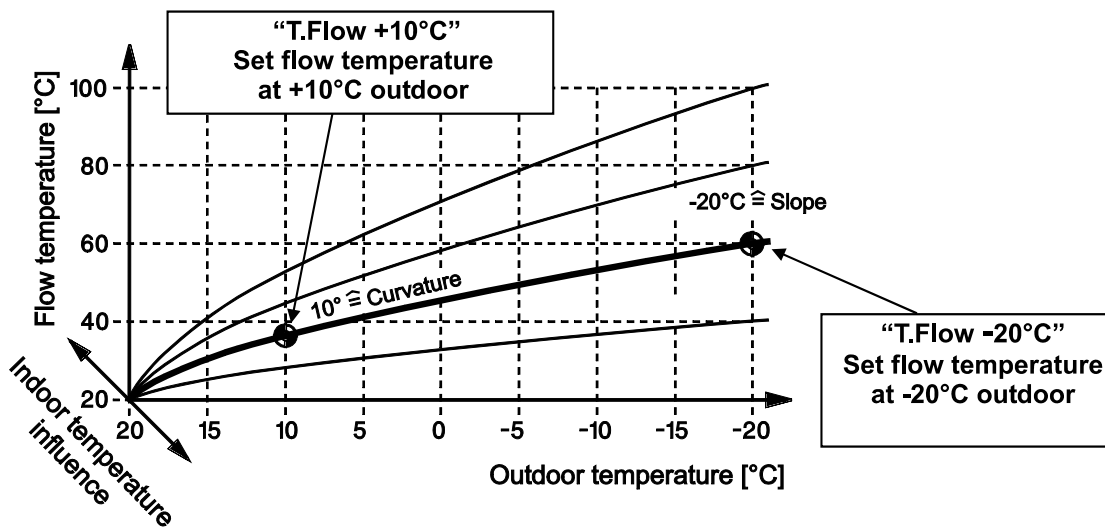

Heat Curve "Rate of rise"

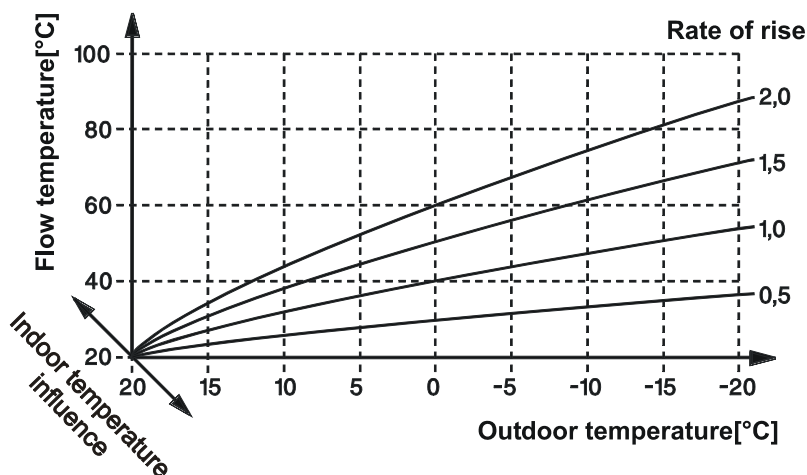

- PREmax** Flow temperature maximum value
 This protection function should prevent overheating of temperature sensitive parts (e.g. floor heating pipes). The mixer control does not permit a higher flow temperature than **PREmax**.
 fs = 70°C, setting range: 31 to 99°C
- PREmin** Flow temperature minimum value
 Even if the calculated flow temperature is below this threshold, a flow temperature below it is nevertheless not permitted.
 fs = 30°C, setting range: 0 to 69°C

Frost protection OTF / RTF

If frost protection is activated, the set flow temperature is maintained at at least **PREmin** according to the set room temperature for frost protection **RTF** (setting in the parameter menu), until the temperature which has triggered the frost protection function increases to 2 K above the frost protection limit.

The frost protection is activated even if a switch-off condition would disable the pump.

Operation mode	Room sensor S1 active or at fixed temperature	Frost protection activation (when the temperature falls below the temperature protection limit)
Automatic/Lowered/Normal	Active	Only via room sensor S1 (RTF), independent of external sensor S2
Automatic/Lowered/Normal	Fixed temperature	No frost protection
Standby, controller setting	Active	Via room sensor S1 (RTF) and external sensor S2 (OTF)
Standby, controller setting	Fix	Via external sensor S2 (OTF)
Standby, setting at the room sensor RAS	Active or fixed temperature	Only via external sensor S2 (OTF)

The status display displays FRO and the symbol  .

- OTF** Outdoor temperature threshold for frost protection mode (fs = +5°C).
 Setting range: -20 to +20°C
- RTF** Room temperature threshold for frost protection mode (fs = +5°C).
 Setting range: 0 to 30°C

Automatic / manual mode

O AUTO

The outputs can be set to manual mode (**O ON**, **O OFF**) for test purposes. To indicate manual mode a hand symbol appears. The active output (pump running) is indicated by illumination of the digit 1 (LED) beside the display. (fs = AUTO)

- Settings:
- AUTO** the output switches in accordance with the program diagram
 - OFF** the output is switched off
 - ON** the output switches on

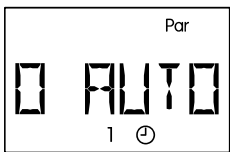
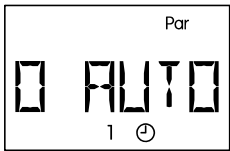

Automatic operation

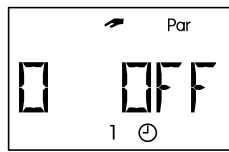

Manual OFF

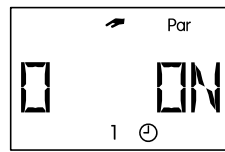

Manual ON

IMPORTANT: If the output is manually switched ON or OFF, the program diagram no longer affects the output.

M AUTO

As with output 1 the mixer (outputs 2+3) can also be switched to manual mode for testing. As soon as switching to **M MAN** has been done an additional display window **M TEST** is released which can be reached by pressing the right-hand arrow key. The lower arrow key releases the test level; **HALT** appears in the display. By continuously pressing the left-hand or right-hand arrow key the mixer is manually transferred to **OPEN** or **CLOSE**. The respective digit beside the display is illuminated.

In this case too, the outputs are no longer controlled from the program level in manual mode.

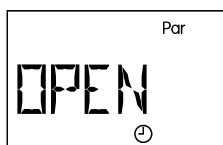
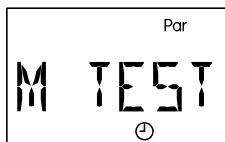
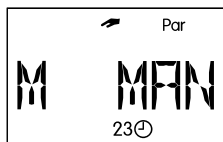
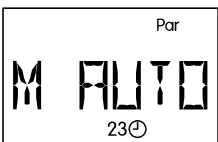
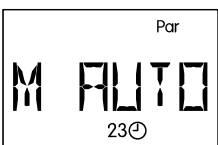

Hold key down

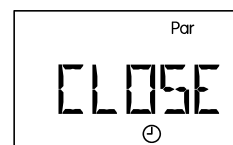
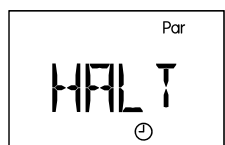

Hold key down

C AUTO

The 2 control outputs are set to automatic mode and can be changed over to manual mode (**C ON**, **C OFF**) for test purposes. To indicate manual mode a hand symbol appears.

Settings: **AUTO** the control output delivers a control voltage between 0 and 10 volts dependent on the settings in the **COP** menu.

OFF the control voltage is always 0 volts

ON the control voltage is always 10 volts

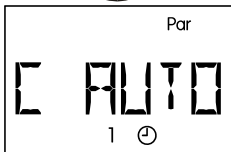
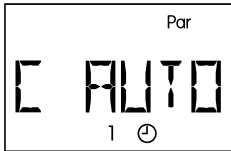

Automatic operation

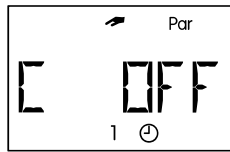

Manual 0 volts

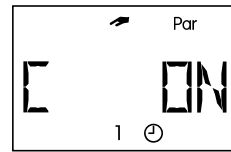

Manual 10 volts

The main menu *Men*

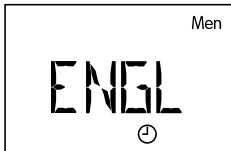

Language



Code number menu entry

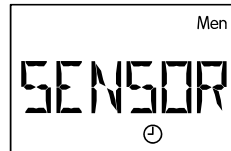

Sensor menu

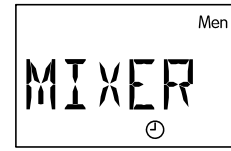

Mixer menu



Heating pumps menu

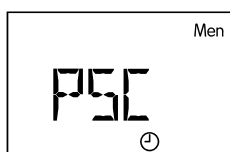

Pump speed control



Control outputs



Heat quantity counter

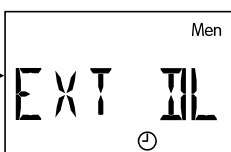

External sensors via data link

Summary

ENGL	Actually chosen menu language = English . Factory settings are made in DEUT (German).
CODE	Code number for entering the menu. The rest of the menu items are only displayed once the correct code number is entered.
SENSOR	Sensor settings: Selection of type of sensor, averaging of sensor values and allocation of symbols for the sensors.
MIXER	Mixer menu : Selection of type of control (outdoor temperature or fixed value), setting of room influence, increase in switch-on power and mixer running time, as well as averaging of the outdoor temperature.
PUMP	Heating pumps menu: Stipulation of switch-off conditions.
PSC	Pump speed control : Stabilizing a temperature by speed control.
COP	Control output available twice (0-10V / PWM) As analogue function (0 to 10 V): output of a voltage between 0 and 10 V. As fixed value of. As PWM (pulse width modulation): output of a frequency. The duty cycle (ON / OFF) conforms to the control signal.
HQC	Heat quantity counter : Operation with volume flow encoder Operation with fixed volume flow
EXT DL	External sensor values from the data link

Language **DEUT, ENGL**

Language selection: The entire menu can be switched to the desired user language even before the code is provided. The following languages are available: German (**DEUT**) and English (**ENGL**).

Factory settings are made in German (**DEUT**).

Code number **CODE**

The additional menu items are only displayed after the correct **code** number (**code number 64**) has been entered.

Sensor menu **SENSOR**

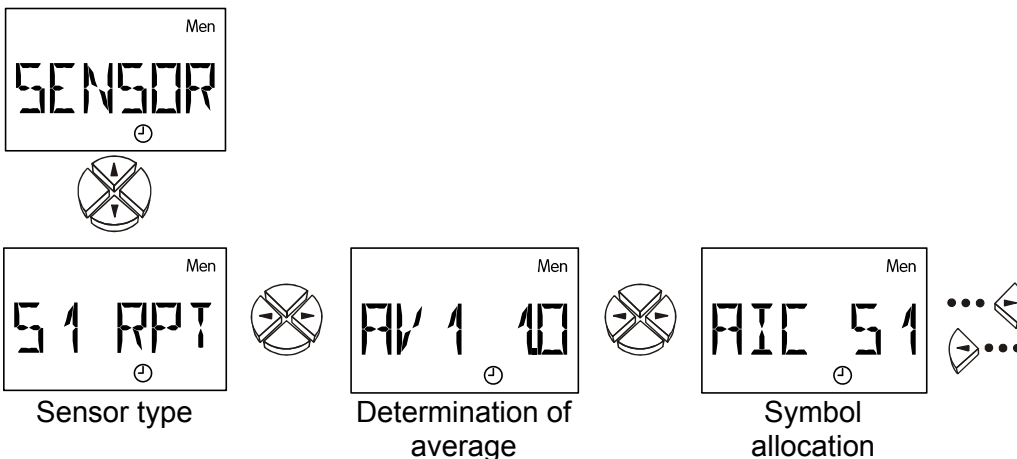

These 3 menu items are available for every sensor.

Sensor type

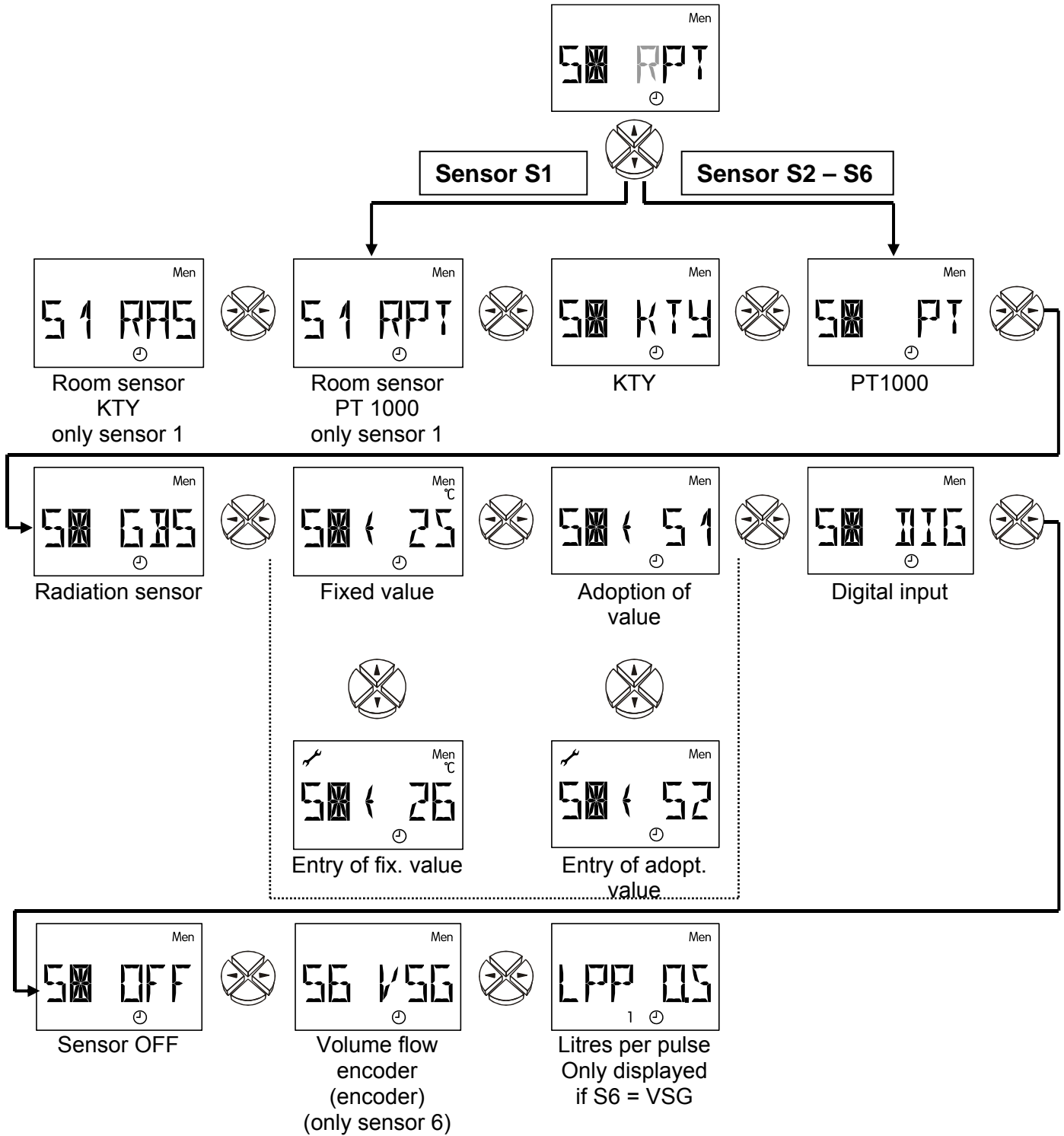

Input 1 is set at the factory to type RPT (PT1000).

RPT, RAS Room sensor **RPT** (= RASPT / Pt1000) or **RAS** (KTY), only on input **S1**

Inputs 2 - 6 are set to PT1000 type in the factory settings.

PT, KTY Temperature sensors

SX ↔ 25 Fixed value: e.g. **25°C** (use of this adjustable temperature for controlling instead of the measured value)

Setting range: -20 to 149°C in increments of 1°C

S2 ↔ S3 **Example:** Instead of a measured value the input **S2** receives its (temperature) information from input **S3**. Reciprocal allocation (according to this example additionally: **S3 ↔ S2**) to cancel information is not permissible.

In addition it is possible to assign values from **external sensors (E1 to E9)**.

DIG **Digital input:** e.g. when using a flow switch.

Input short-circuited (ON): Display: **D 1**

Input interrupted (OFF): Display: **D 0**

OFF Sensor is hidden in the main level

VSG Volume flow encoder: **Only on input S6** to read the impulses from a volume flow encoder (determining the flow rate for the heat quantity counter)

LPP **Litres per pulse** = the volume flow encoder's pulse rate (only when sensor type S6 = VSG). (ex works = 0.5)

Setting range: 0.0 to 10.0 litres/pulse in increments of 0.1 litre/pulse

Determination of average AV

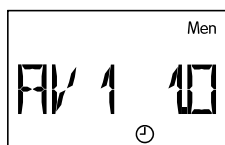

Setting of the time in seconds over which an averaging of the measured value should be carried out (fs = 1.0s).

Example: AV1 1.0 Averaging sensor S1 over 1.0 seconds

For simple measuring operations approx. 1.0 - 2.0 should be selected. A high average slows everything down and is only recommended for the sensors for the heat quantity counter.

The measuring of the ultra-fast sensor for the hygienic hot water preparation makes a fast evaluation of the signal necessary. The averaging of the respective sensor should therefore be reduced to 0.3 to 0.5 although that means that slight fluctuations of the display should be expected.

No averaging is possible for the volume flow encoder VSG.

Setting range: 0.0 to 6.0 seconds in increments of 0.1 sec.

0.0 = no averaging

Symbol allocation A/C

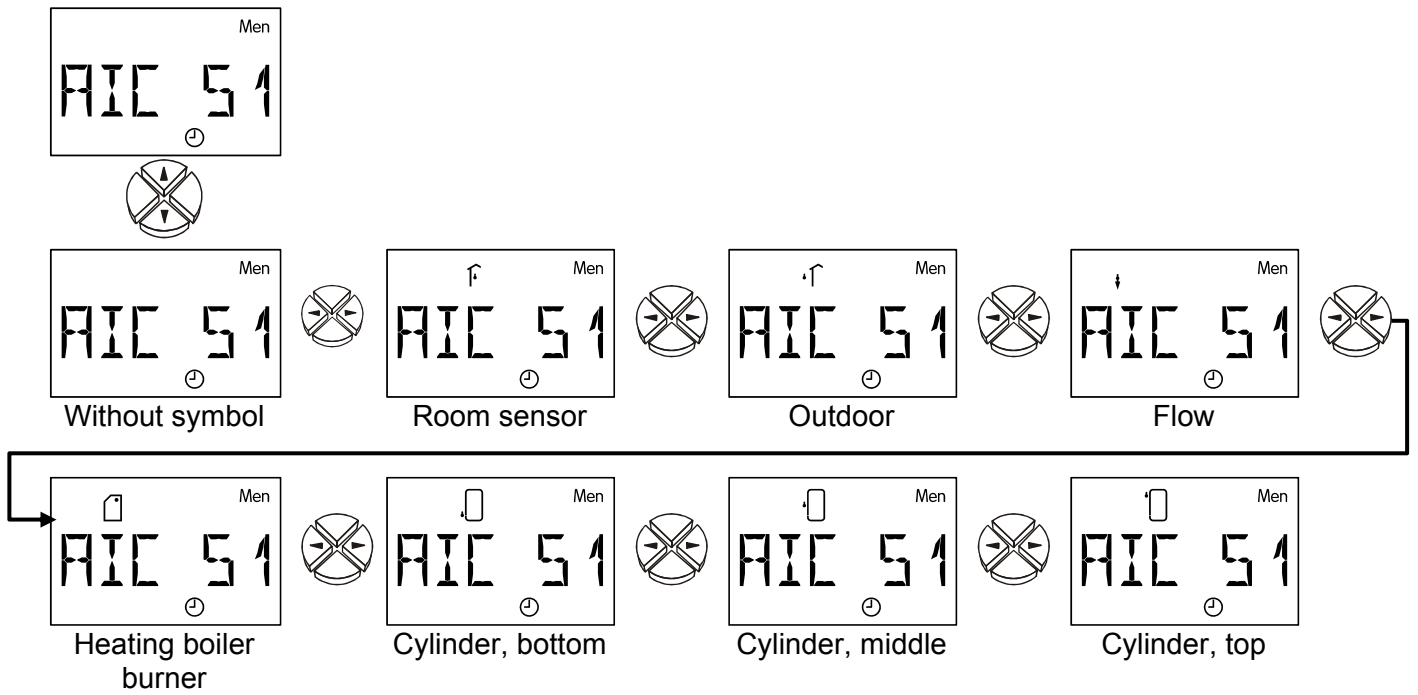

Every input can be assigned any of the above symbols. Although it doesn't make a great deal of sense it is also possible to assign several inputs (sensors) the same symbol.

Symbol allocation has no influence on the control function.

Mixer menu *MIXER*

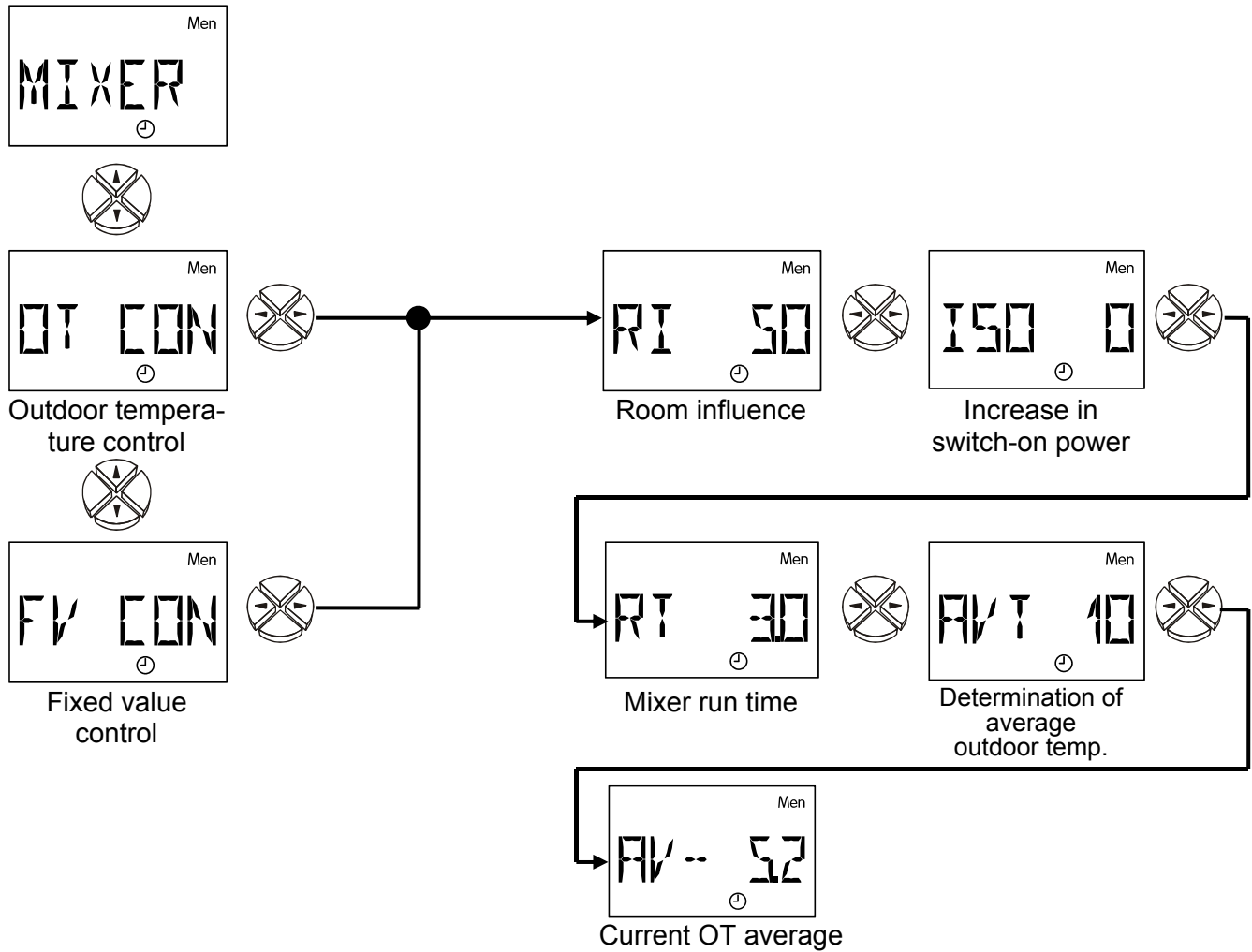

OT CON Type of control: Outdoor temperature. Calculation of set flow temperature from the outdoor temperature and a pre-determined correlation (Temperature or rate of rise, setting in parameter menu **Par**).

FV CON Type of control: Fixed value control. The flow is controlled to the specified temperature of +10°C in lowering mode and to that of -20°C in heating mode (setting in parameter menu **Par**).

Important instruction for fixed value control: As room influence is still active, then if a room sensor is being used, the room influence **RI** must be set to zero.

RI Room influence. The respective room temperature is taken into consideration for calculating of the flow. (fs = 50%) Setting range: 0 – 90%

ISO Increase in switch-on power in % relative to a lowering time of 10 hours. The previous lowering period leads to an excessive increase (receding over time) of the flow temperature to shorten the dwell time.(fs = 0%) Setting range: 0 – 9%

RT Total mixer run time in minutes. (fs = 3.0)
Setting range: 0 to 30 min

AVT Averaging time of the outdoor temperature for the calculation of the set flow in minutes. Compensation of the fluctuating outdoor temperatures for the calculating the flow temperature. (fs = 10) Setting range: 0 to 255 min

AV Actual average value for the outdoor temperature.

Heating pump menu *PUMP*

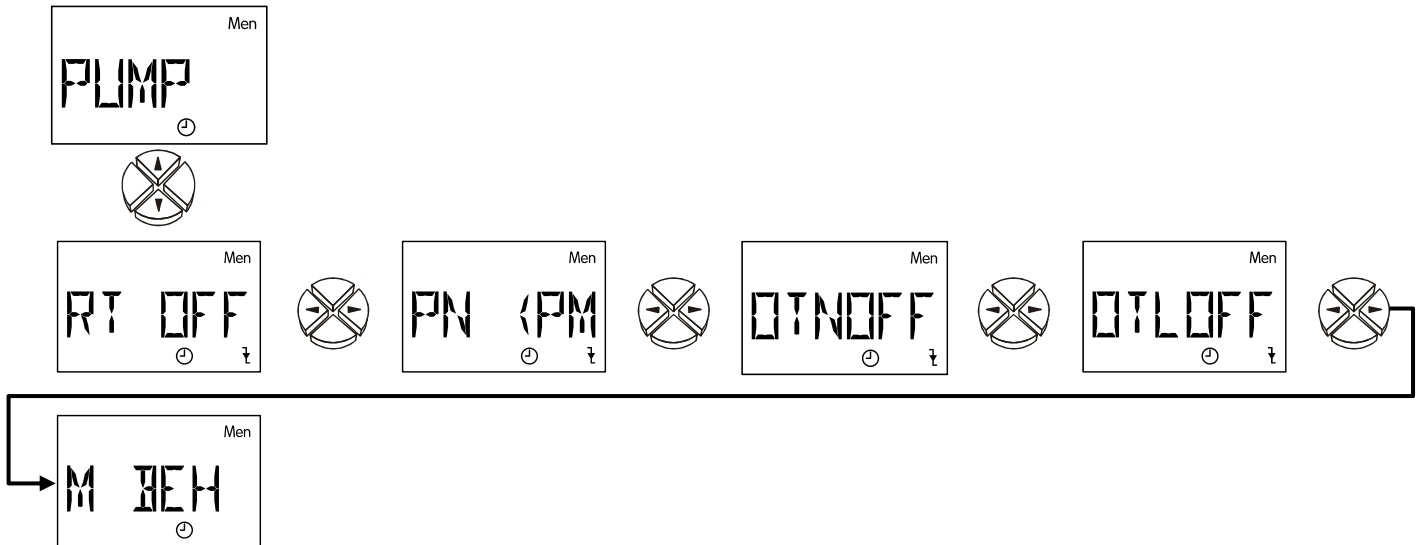

In this menu the **switch-off conditions for the heating pump** and the mixer behaviour with switched-off pump are specified.

RT OFF Switch off when set room temperature has been reached.

PN < PM Switch off when the calculated set flow temperature falls below the minimum flow temperature.

OTNOFF Switch off when the average outdoor temperature exceeds a specified value in normal operation.

OTLOFF Switch off when the average outdoor temperature exceeds a specified value in lowering mode.

M BEH Mixer behaviour when switching off the heating pump.

Switch-off when the set room temperature is reached

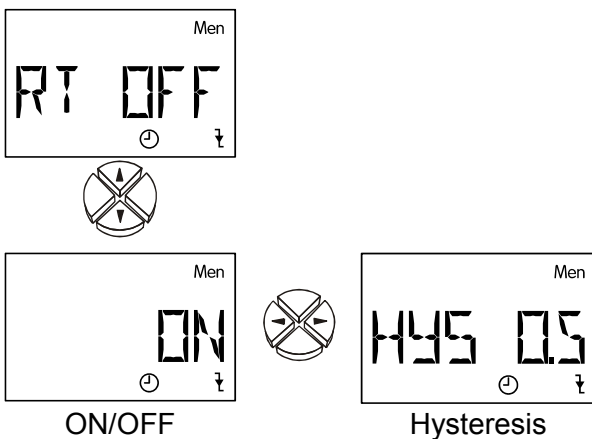

ON/OFF Switch-off condition activate/deactivate. (fs = OFF)

Base temperature is the set room temperature for normal or lowering mode in the basic control level (**RTN** / **RTL**).

HYS Switching hysteresis of the base temperature. (fs = 0.5 K) Setting range: 0 to 25 K

The switching hysteresis has an upward effect. **Example:** with a set room temperature of 20°C and a hysteresis of 0.5K the pump is switched off at 20.5°C as the temperature increases and switched on again at 20.0°C as the temperature falls.

Switch-off when fallen below the minimum flow temperature

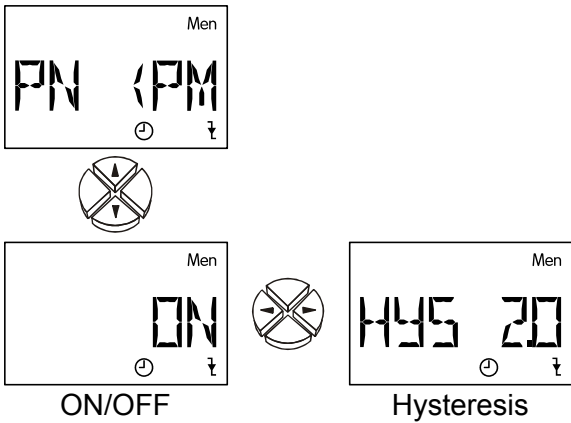

ON/OFF Switch-off condition activate/deactivate. (fs = OFF)

Base temperature is the minimum flow temperature PREmin specified in the parameter menu.

HYS Switching hysteresis of the base temperature. (fs = 2.0 K) Setting range: 0 to 25 K

The switching hysteresis has a downward effect. **Example:** For a **PREmin** of 30°C and a hysteresis of 2.0K the pump is switched off with a falling set flow temperature at 28°C and switched on again with an increasing set flow temperature at 30.0°C.

Switch-off when outdoor temperature is exceeded - heating mode

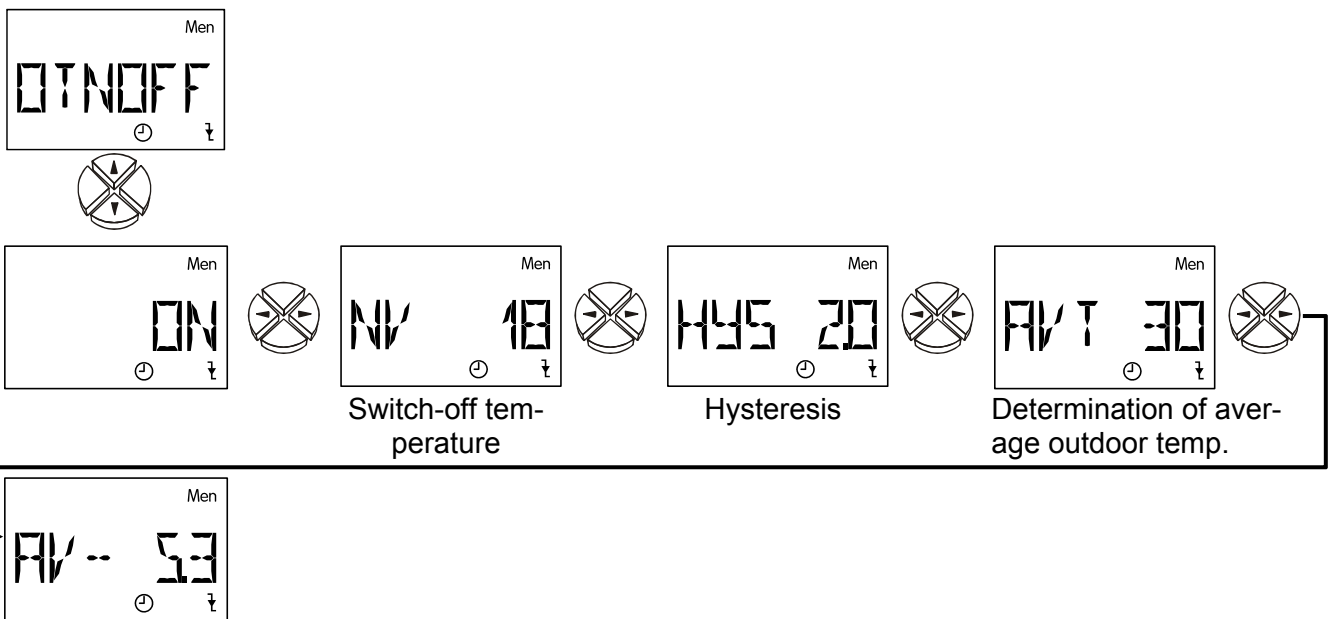

Current OT average

ON/OFF Switch-off condition activate/deactivate. (fs = ON)

NV Set outdoor temperature for switch-off (fs = 18°C) Setting range: -20 to 99°C

HYS Switching hysteresis (fs = 2.0 K) Setting range: 0 to 25 K

The switching hysteresis has an upward effect. **Example:** with a switch-off temperature of **NV** 18°C and a hysteresis of 2.0K the pump is switched off at 20.0°C as the temperature increases and switched on again at 18.0°C as the temperature falls.

AVT Averaging time of the outdoor temperature for the switch-off the pump in minutes. Compensation of fluctuating outdoor temperatures. This value is identical to the (mean time) AVT value under the switch off condition OTLOFF. (fs = 30 min) Setting range: 0 to 255 min

AV Actual average value for the outdoor temperature.

Switch-off when outdoor temperature is exceeded - lowering mode

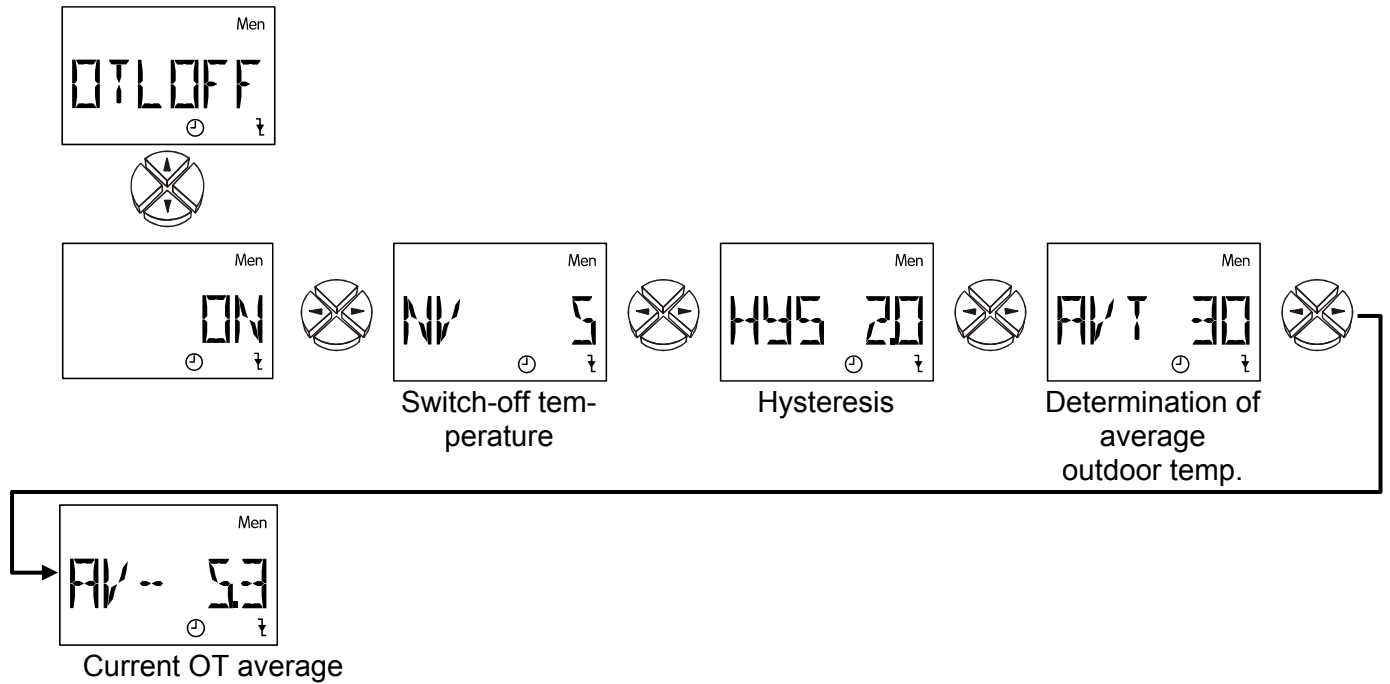

ON/OFF Switch-off condition activate/deactivate. (fs = OFF)

NV Set outdoor temperature for switch off. (fs = 5°C) Setting range: -20 to 99°C

HYS Switching hysteresis (fs = 2.0 K) setting range: 0 to 25 K

The switching hysteresis has an upward effect. **Example:** with a switch-off temperature of **NV** 5°C and a hysteresis of 2.0K the pump is switched off at 7°C as the temperature increases and switched on again at 5.0°C as the temperature falls.

AVT Averaging time of the outdoor temperature for the switch-off the pump in minutes. Compensation of fluctuating outdoor temperatures. This value is identical to the (mean time) AVT value under the switch off condition OTNOFF. (fs = 30 min) Setting range: 0 to 255 min

AV Actual average value for the outdoor temperature.

Mixer behaviour

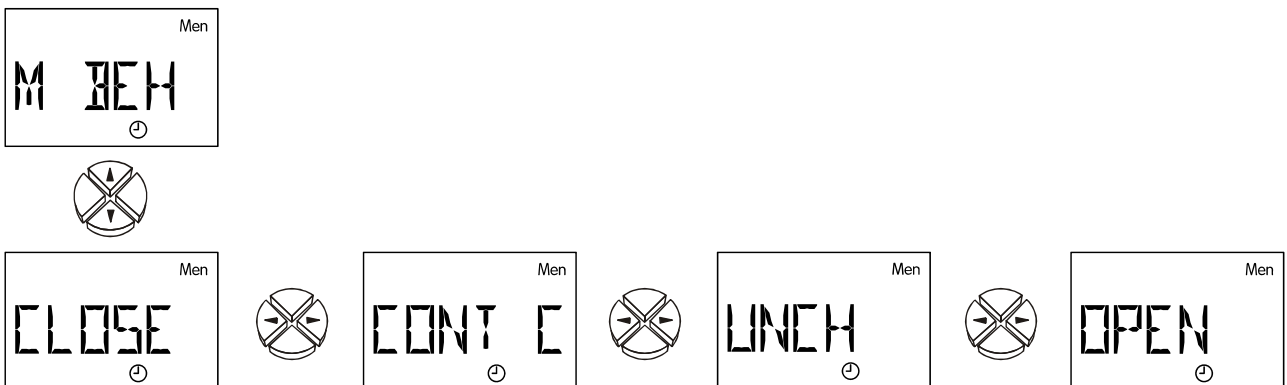

Specifying how the mixer should behave after the pump has been switched off:

Close, continue control, stand still unchanged, open.

Factory setting: Close

Pump speed control *PSC*

Pump speed control *PSC* is not suitable for electronic or high efficiency pumps.

Warning! The values in the following description are by way of example only; they must, in all cases, be matched to the system!

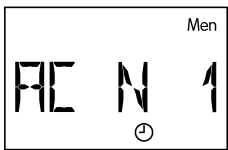
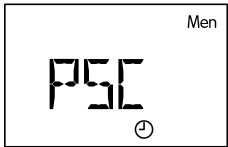

Absolute value control

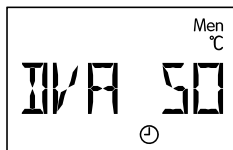

Set value absolute value control



Differential control

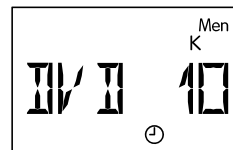

Set value differential control



Event control



Set value of the event

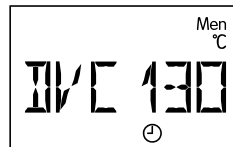

Set value of the control



Wave packet or phase angle

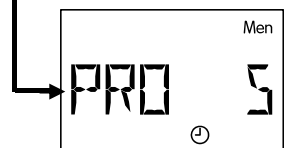

Proportion part



Integral part

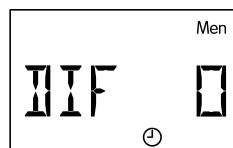

Differential part



Minimum speed stage



Maximum speed stage

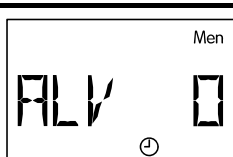

Delay time



Current speed

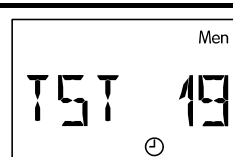

Setting test speed

The behaviour of the control circuit is equal to that of the control outputs (COP); however, instead of 100 (COP) a maximum of 30 increments is available.

The description of the parameter values follows in the menu "COP".

Waveform

Two waveforms are available for motor control. (fs = WAVEP)

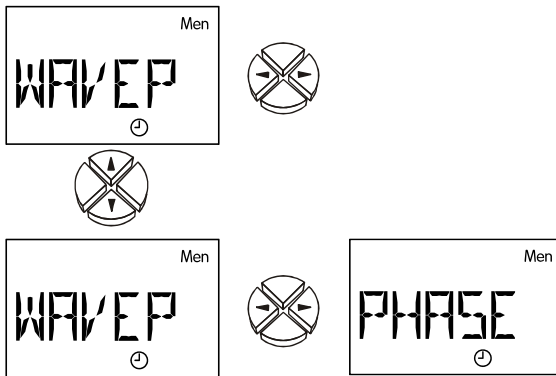

WAVEP Wave packet - Only for circulating pumps with standard motor dimensions. Here, individual half-waves are blended in to the pump motor. The pump is run via pulses, and “smooth running” is only created by the moment of inertia of the rotor and the heat carrier.

Benefit: Great dynamics of 1:10, well suited for usual commercial pumps without internal electronics and a motor length of around 8 cm.

Drawback: Linearity depends on the pressure loss; there is some noise; not suitable for pumps of which the motor diameters and/or length deviate markedly from 8 cm.

PHASE Phase angle - For pump and fan motors without internal electronics. The pump is switched to the mains within each half-wave at a certain point in time (phase).

Benefit: Suitable for almost all types of motors

Drawback: Low dynamics of 1:3 for pumps. **A filter has to be inserted upstream from the unit with at least 1.8mH and 68nF to fulfil the CE standards for interference suppression.**

NOTICE

The menu allows a choice between wave packet and phase angle however in the standard version the output of waveform "phase angle" is not possible!
Special versions on request.

Control output *COP* 0 to 10 V / PWM (twice)

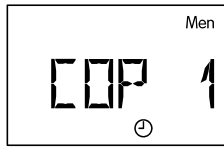
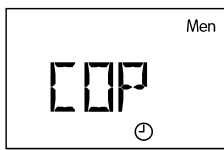

Control output 1

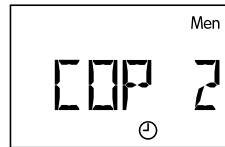

Control output 2

Different functions of the control output

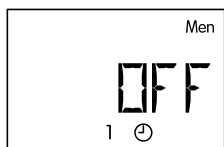
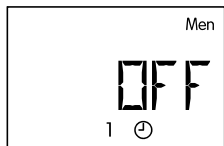

Control output deactivated

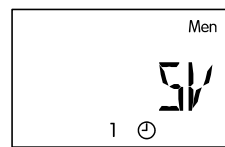

5V power supply

Control output number

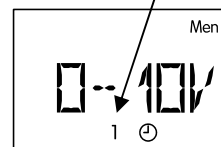

0 - 10V output



PWM output

- OFF** Control output deactivated; output = 0V
- 5V** Power supply; output = 5V
- 0 to 10V** PID – controller; output = 0 to 10V in 0.1V increments
- PWM** PID – controller; output = duty cycle 0 to 100% in 1% increments

The following settings are only possible in **0 to 10V** and **PWM** modes:

Warning! The values in the following description are by way of example only; they must, in all cases, be matched to the system!

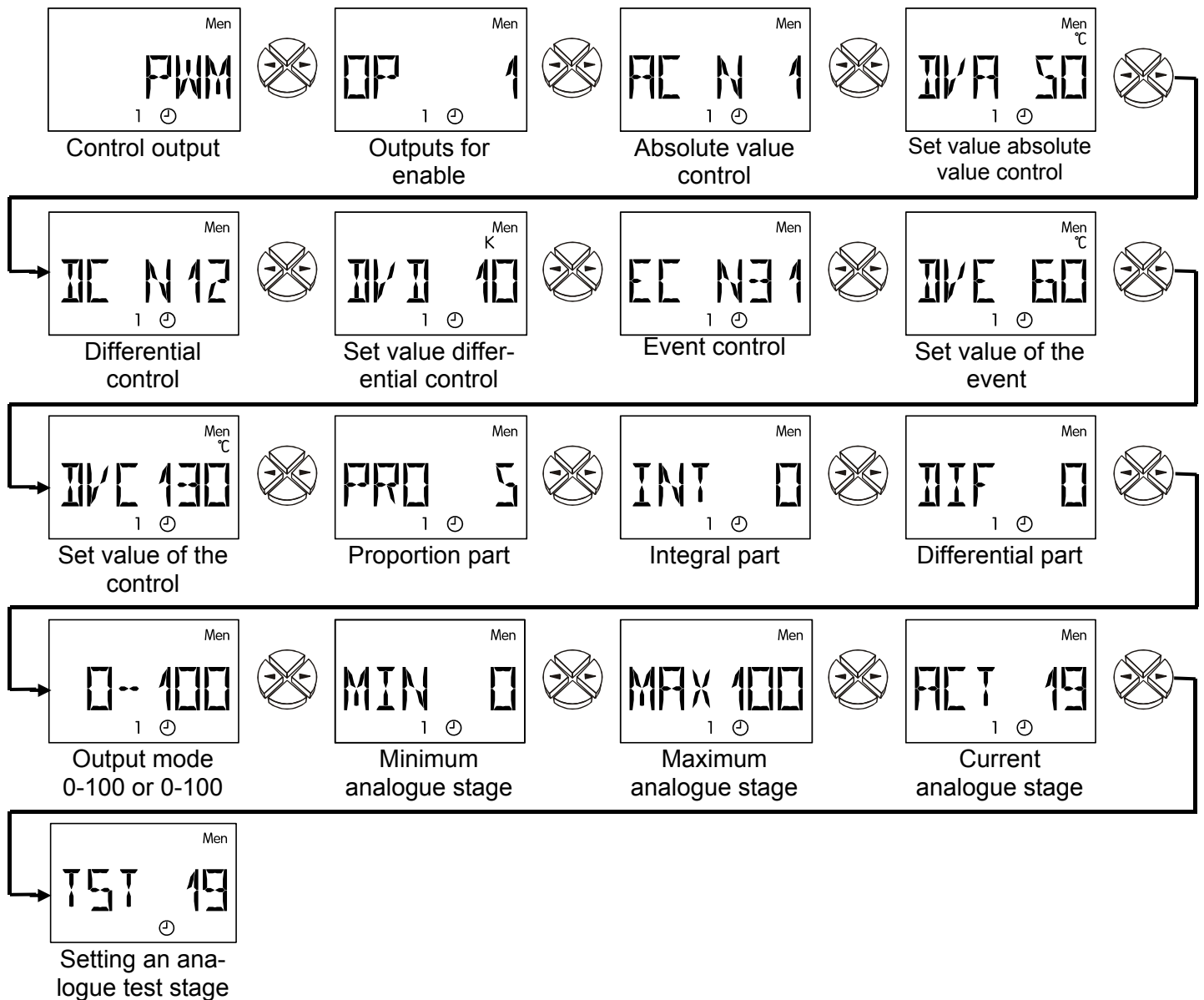

In this menu the parameters for the control output are specified.

As analogue output it can put out a voltage of 0 to 10V in 0.1V increments.

As PWM a digital signal with a frequency of **500 Hz (level approx. 10 V)** and a variable duty cycle from 0 to 100% is created.

The control outputs are deactivated at the factory. In the active state, they can be enabled by an assigned output, i.e. by an output specified by the schematic and the program number.

If a control output (0 to 10V or PWM) is activated, then the analogue stage is displayed in the basic menu after the measured values below "ANL 1" or "ANL 2".

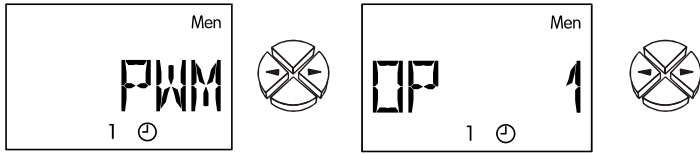

OP Setting the outputs to enable the control output.
 In other words, the analogue output is only released if the output set here is switched on.
 If no output is selected, then the analogue output is **always** released.
 Setting range: combination of all outputs (such as OP1, OP23, OP123)
 OP -- = The analogue output is not assigned to any output; rather, it runs independently. (fs = --)

Absolute value control = stabilization of a sensor

A temperature sensor can easily be held at a constant temperature by controlling the speed (e.g.: controlling a heating circuit via a fixed value control together with a pump speed control). Alternatively in many systems it can be useful to have a constant return. This requires an inverse control characteristic. If the return temperature increases the flow rate is reduced.

The absolute value control is specified using two parameter windows.

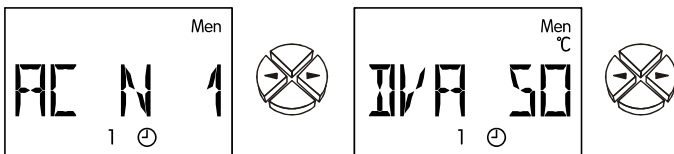

AC N 1 Absolute value control in normal operation whereby sensor S1 is kept constant.
Normal operation N means that the speed increases with the increasing temperature and is applicable for keeping a "flow" sensor constant (e.g. boiler).
Inverse mode I means that the speed reduces with increasing temperature and is necessary for keeping a return constant. (fs = --)
 Setting range: AC N 1 to AC N6, AC I 1 to AC I 6
 AC -- = Absolute value control is deactivated.

DVA 50 The set value of the absolute value control is **50°C**. According to the example therefore S1 is stabilized at 50°C. As a set value **DVA** the set flow temperature **NP** can also be selected (the set position is between 99°C and 0°C.). (fs = 50°C)
 Setting range: 0 to 99°C in increments of 1°C

Differential Control = stabilization of the temperature between two sensors.

Stabilization of the temperature difference between e.g. S1 and S2 provides 'smooth' operation.

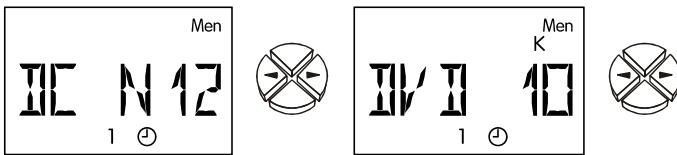

DC N12 Differential control in normal operation between sensor S1 and S2. (fs = --)
Setting range: DC N12 to DC N65, DC I12 to DC I65)

DC -- = Differential control is deactivated.

DVD 10 The set value of the differential control is **10K**. According to the example therefore the temperature difference between S1 and S2 is stabilized at 10K.

Warning: DVD must always be greater than the switch-off differential of the basic function. With a smaller DVD the basic function blocks the release of the pump before the speed control has reached the set value. (fs = 10K)

Setting range: 0.0 to 9.9K in increments of 0.1K; 10 to 99K in increments of 1K

If the absolute value control (stabilization of a sensor) and the differential control (stabilizing the differential between two sensors) are both active at the same time, the "slower speed wins out".

Event control = If a set temperature event occurs, the speed control starts, thus keeping a sensor constant.

When S3 has reached 60°C (activation threshold) for example S1 is kept at a certain temperature. The respective stabilization of the sensor functions as it does for the absolute value control.

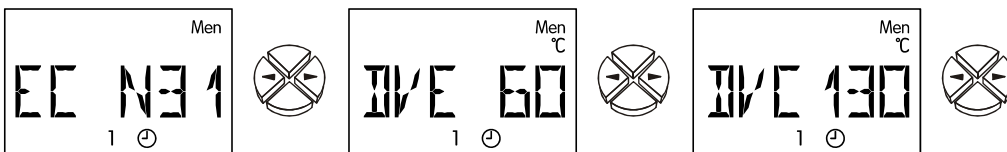

EC N31 Event control in normal operation; an event occurring at sensor S3 leads to stabilization of the sensor S1. (fs = --)

Setting range: EC N12 to EC N65, EC I12 to EC I65

EC -- = Event control is deactivated.

DVE 60 The threshold value of the event control is **60°C**. Above a temperature of 60°C at S3 the speed controller is activated. (fs = 60°C)

Setting range: 0 to 99°C in increments of 1°C

DVC 130 The set value of the event control is **130°C**. As soon as this event occurs, S1 is stabilized at 10°C. (fs = 130°C)

Setting range: 0 to 199°C in increments of 1°C

The event control "overwrites" the speed results from other regulation methods. Hence, a set event can block the absolute value control or differential control.

Stability problems

The speed control contains a "PID controller". It guarantees exact and fast matching of the actual value to the set value. In applications such as solar systems or load pumps the parameters of the factory setting guarantee stable behaviour. In special cases though comparison is imperative.

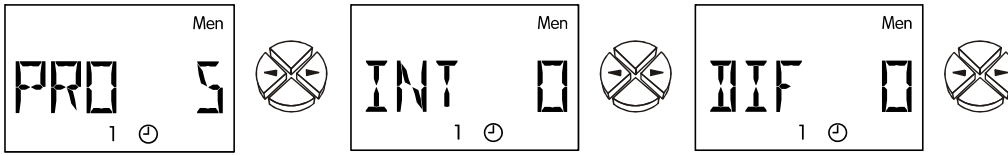

Set value = desired temperature Actual value = measured temperature

PRO 5 Proportion part of the PID controller **5**. It represents the reinforcement of the deviation between set and actual value. The speed is changed one increment per **0.5K** deviation from the set value. A high number leads to a more stable system but also to greater deviation from the temperature set.

(fs = 5) Setting range: 0 to 100

INT 5 Integral part of the PID controller **5**. Periodically adjusts the speed relative to the deviation remaining from the proportional part. For **1K** of deviation from the set value, the speed is changed one increment every **5** seconds. A larger number makes the system stable, but the adjustment to the set value is slower.

(fs = 0) Setting range: 0 to 100

DIF 5 Differential part of the PID controller **5**. The faster a deviation between set and actual value occurs the greater the tendency to short-term "overreaction" in order to achieve compensation as fast as possible. If the set value deviates at a speed of **0.5K** per second, the speed is changed by one increment. Higher values provide a more stable system but adjustment to the set value is slower.

(fs = 0) Setting range: 0 to 100

The parameters PRO, INT, and DIF can be determined by a test:

The pump should be running in automatic operation with the system ready for operation with the appropriate temperatures. With INT and DIF set to zero (= switched off), PRO is reduced from 10 every 30 seconds until the system becomes unstable i.e. the pump speed changes its rhythm; it can be read off in the menu under command ACT. The proportional part at which instability begins is noted as P_{krit} , with the duration of the oscillation (= time between the two highest speeds) noted as t_{krit} . The correct parameters can be determined with the following formulae.

$$PRO = 1,6 \times P_{krit}$$

$$INT = \frac{PRO \times t_{krit}}{20}$$

$$DIF = \frac{PRO \times 8}{t_{krit}}$$

Output mode, output limits

Depending on the pump version, the control mode of the pump can be normal (0 – 100 “solar mode”) or inverse (100 – 0, “heating mode”). There can also be specific requirements for the limits of the control range. These can be found in the information of the pump manufacturer.

The following parameters define the control mode and the lower and upper limits of the output analogue value:

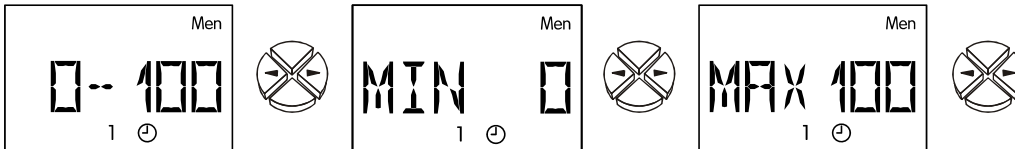

0-100 Output mode setting: 0-100 corresponds to 0->10V or 0->100% PWM, 100-0 corresponds to 10->0V or 100->0% PWM (inverse). (fs = 0-100)

MIN Lower speed limit (fs = 0)

MAX Upper speed limit (fs = 100)

Control commands

Using the following commands a system test (see pump standstill) or monitoring of the actual speed (see stability problems) is possible:

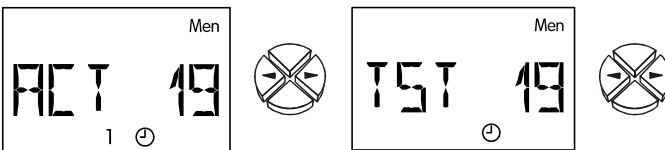

ACT 19 Currently the pump is running (actual value) at speed stage **19**.

TST 19 Currently the speed stage **19** is issued on a **test** basis. Invoking TST automatically results in manual mode. As soon as the value above the key \downarrow (= Entry) blinks the pump is controlled at the speed stage displayed.

Setting range: 0 to 100 with keys $\leftarrow \rightarrow$

Heat quantity meter *HQC* (three times)



Heat quantity meter 1



Heat quantity meter 2



Heat quantity meter 3

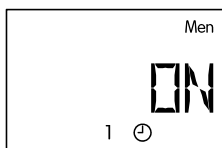

ON/OFF

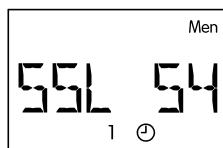

Sensor flow line

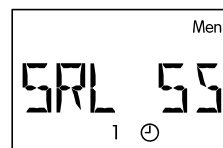

Sensor return line

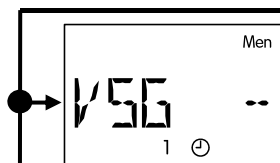

No volume flow encoder

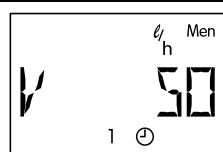

Fixed volume flow

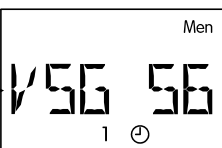

VSG to S6 (encoder)

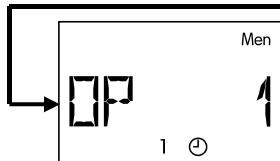

Assigned outputs

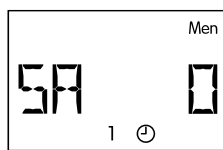

Frost protection share



Sensor comparison



Meter delete

The device has a function for determining the heat quantity. It is deactivated ex works. A heat quantity meter fundamentally requires three details. These are:

flow temperature, return temperature, flow rate (volume flow)

Furthermore in order to increase the accuracy it is necessary to specify the frost protection share in the heat transfer medium since the frost protection reduces its heat-transporting capacity. The flow rate can be made as a direct entry or via an additional sensor with specified pulse rate.

ON/OFF Heat quantity meter activate/deactivate (fs = OFF)

SSL Sensor input of flow temperature (fs = S4)

Setting range: S1 to S6 Input of the flow sensor
E1 to E9 Value from external sensor via DL

SRL Sensor input of return temperature (fs = S5)

Setting range: S1 to S6 Input of the return sensor
E1 to E9 Value from external sensor via DL

VSG Sensor input for volume flow encoder. (fs = --)

The pulse encoder **VSG** can only be connected to input S6. For this purpose the following settings must be made in the **SENSOR** menu without fail:

S6 VSG Volume flow sensor with pulse encoder

LPP Litres per pulse

Setting range: VSG S6 = volume flow encoder **at input 6**.

VSG E1 to E9 = Value from external sensor **via DL-Bus**

VSG -- = no volume flow encoder → fixed volume flow. For the calculation of the heat amount, the set volume flow is only used if the set output is active

V Volume flow in litres per hour. Without a volume flow encoder a fixed volume flow can be set in this menu. If the set output is not active the volume flow is assumed to be 0 litres/hour. Since an activated speed control always results in other volume flows this procedure is not suitable together with the speed control. (fs = 50 l/h)

Setting range: 0 to 20000 litres/hour in 10 litre/hour increments

OP Assigned **outputs**. The set/measured volume flow is only used to calculate the heat quantity if the output specified here is active (or at least one of several outputs). (fs = --)

Setting range: OP = -- heat quantity is calculated without any consideration to the outputs.

Combinations of all outputs (e.g. OP1, OP23, OP123)

SA Frost protection share of the heat transfer medium. An average is calculated from the product information of all relevant manufacturers and implemented in the form of a table according to mixing ratios. Under typical conditions this method results in an additional maximum error of one percent. (fs = 0%)

Setting range: 0 to 100% in 1% increments

DIF Current temperature **difference** between flow and return sensor (Maximum display ± 8.5 K, additionally an arrow is displayed). If both sensors are submersed simultaneously in a bath for test purposes (both therefore measure the same temperature) the device should display "**DIF 0**". As a result of the tolerances of the sensors and the measuring movement of the device however a differential is displayed under **DIF**. If this display is set to zero, the computer saves the differential as correction factor and corrects this natural error in future calculations of the heat quantity. **This menu item therefore represents calibration facility. The display may only be set to zero (or altered) when both sensors have identical measuring conditions (together in the same bath).** For this purpose a medium at a temperature of 40°C to 60°C is recommended.

HQC CL Delete heat quantity meter. The totalled heat quantity can be deleted with this command with the key \downarrow (= entry).

If the heat quantity is zero **CLEAR** is displayed in this menu item.

If the heat quantity meter has been activated the following are displayed in the basic menu:

- the current performance in kW
- the heat quantity in MWh and kWh
- the volume flow in litres/hour

IMPORTANT: If an error occurs on one of the set sensors (flow sensor, return sensor) of the heat quantity meter (short circuit, interruption) the current performance is set to zero and as a result no heat quantity is added.

NOTICE: As the internal storage (EEPROM) has only a limited number of write cycles, the totalled heat quantity is saved only once per hour. For this reason, it is possible that a power failure can result in loss of the heat-quantity data for one hour.

Notes on accuracy:

A heat quantity meter can only be as accurate as the sensors and the movement of the measuring device. In the range from 10°C to 90°C the standard solar control sensors (PT1000) have an accuracy of approximately ± 0.5 K. For KTY sensors the equivalent figure is ± 1 K. The measuring movement of the device is accurate to around ± 0.5 K based on laboratory measurements. PT1000 sensors may be more accurate but they supply a smaller signal which increases the error of the measured value. In addition the orderly installation of the sensors is extremely important. Incorrect installation can further substantially increase the margin of error.

If all the tolerances are now added together in the worst case scenario the total error for a typical temperature differential of 10K would be 40% (KTY). In reality however an error of less than 10% can be expected because the error of the measuring movement affects all input channels the same and the sensors are from the same production batch. In part therefore the tolerances cancel each other out. The basic principle applies: The larger the temperature differential the smaller the error. When all factors are taken into account the measurement result should be seen as a guide value only. Through alignment of the measured differential (see **DIF**) the measuring error is less than 5% in standard applications.

External sensors *EXT DL*

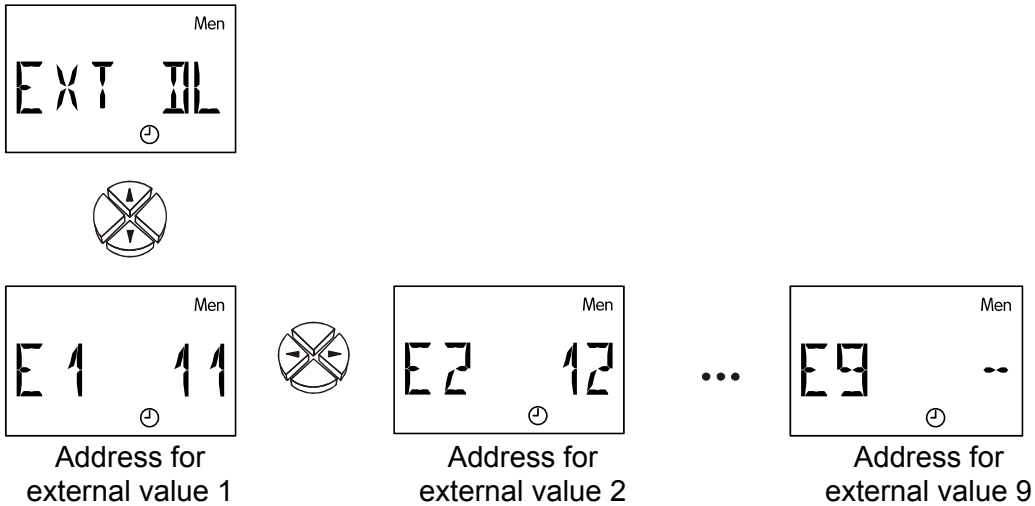

Electronic sensors for temperature, pressure, humidity, differential pressure, etc. are also available in the **DL** version. In this case, the supply and signal transmission takes place via the **DL bus**.

Up to 9 values from external sensors can be read via the data link.

The values of the electronic sensors can be taken from sensor inputs for further control tasks (adjustment in the **SENSOR** menu, transfer of values).

- E1 --** The external value 1 is deactivated and faded out in the main level.
- E1 11** The **front** number indicates the address of the external sensor. This can be set to between 1 and 8 on the sensor according to its operating instructions.
The **rear** number indicates the index of the sensor value. Since external sensors can transmit numerous values the value required from the sensor is defined via the index.

The setting of the address and index can be taken from the respective data sheets.

Due to the relatively high power requirement, the "**bus load**" must be considered:

The controller UVR 63H delivers the maximum bus load 100%. For example, the electronic sensor FTS4-50**DL** has a bus load of 25%, therefore up to a max. 4 FTS4-50**DL** can be connected to the DL bus. The bus loads of the electronic sensors are listed in the technical data of the respective sensors.

Tips on troubleshooting

Standard practice for suspected malfunction should be to first of all check all settings in the menus **Par** and **Men** as well as the terminals.

Malfunction but "realistic" temperature values:

- ◆ Check the program number.
- ◆ Check the switch-on and switch-off thresholds as well as the temperature differential settings. Have the thermostat and differential thresholds already (or not yet) been reached?
- ◆ Have settings been changed in the submenus (**Men**)?
- ◆ Is it possible to switch the output on and off in manual mode? - If endurance runs and standstills at the output result in appropriate reactions the device is definitely in order.
- ◆ Are all sensors connected to the correct terminals? - Heat the sensors using a lighter and check the display.

Wrongly displayed temperature(s):

- ◆ If a value such as -999 is displayed when a sensor short-circuits or 999 if there is a sensor interruption, the cause may not be a material or terminal error. Are the correct sensor types (KTY or PT1000) selected in menu **Men** under **SENSOR**?

The factory setting sets all inputs to PT (1000).

- ◆ The sensor can also be checked without a measuring device simply by changing the sensor that is probably defective with one that works at the strip terminal and checking the temperature display. The resistance measured with an ohmmeter should have following value according to temperature:

Temp. [°C]	0	10	20	25	30	40	50	60	70	80	90	100
R (Pt1000) [Ω]	1000	1039	1078	1097	1117	1155	1194	1232	1271	1309	1347	1385
R (KTY) [Ω]	1630	1772	1922	2000	2080	2245	2417	2597	2785	2980	3182	3392

The factory setting of the parameter and menu functions can be restored at any time by pressing the lower key (Entry) during plugging in. WELOAD appears in the display for three seconds to indicate loading of the factory setting.

If in spite of connection to the supply voltage the device is not working the 3.15A fast-acting fuse which protects the controls and the output should be checked or replaced.

Since the programs are continually being revised and improved it is possible that there are differences in the sensor, pump and program numbering compared with older documentation. Only the accompanying operating manual is valid for the device supplied (identical serial number). The program version of the manual must categorically correspond with that of the device.

Should in spite of inspecting and checking in accordance with the above-mentioned tips a malfunction of the controller be apparent please get in contact with your dealer or directly with the manufacturer. The cause of the malfunction can only be found however when in addition to the description of the malfunction **a fully completed table of the settings** and if possible a hydraulics diagram for the system are provided.

Table of settings

Should an unexpected failure of the controls occur the complete setting must be restored for the start-up. In such cases problems can be avoided if all the set values are entered in the following table. **In the event of queries this table must be provided without fail.** Only then is a simulation and recognition of an error possible.

FS factory settings

CS Controller settings

	FS	CS		FS	CS
Values					
Time			External value E1		
Sensor S1 (TR)		°C	External value E2		
Sensor S2 (TO)		°C	External value E3		
Sensor S3 (TP)		°C	External value E4		
Set flow temp. NP		°C	External value E5		
Sensor S4		°C	External value E6		
Sensor S5		°C	External value E7		
Sensor S6		°C	External value E8		
Speed stage SPS			External value E9		
Analogue stage 1 ANL					
Analogue stage 2 ANL					

Heating circuit controller			Desired room temperature		
Status display			Lowering mode RTL	15 °C	°C
Operating mode			Normal operation RTN	22 °C	°C
Additional par. mode					

Time programs						
	TIMEP1		TIMEP 2		TIMEP 3	
MO		ON		OFF		OFF
TU		ON		OFF		OFF
WE		ON		OFF		OFF
TH		ON		OFF		OFF
FR		ON		OFF		OFF
SA		ON		OFF		OFF
SU		ON		OFF		OFF
TIMEW1 on		05.30		00.00		00.00
off		22.00		00.00		00.00
NV		--		--		--
TIMEW2 on		00.00		00.00		00.00
off		00.00		00.00		00.00
NV		--		--		--
TIMEW3 on		00.00		00.00		00.00
off		00.00		00.00		00.00
NV		--		--		--

	TIMEP 4		TIMEP5	
MO		OFF		OFF
TU		OFF		OFF
WE		OFF		OFF
TH		OFF		OFF
FR		OFF		OFF
SA		OFF		OFF
SU		OFF		OFF
TIMEW1 on		00.00		00.00
off		00.00		00.00
NV		--		--
TIMEW2 on		00.00		00.00
off		00.00		00.00
NV		--		--
TIMEW3 on		00.00		00.00
off		00.00		00.00
NV		--		--

Shiftworker-Timeprogram SWP		--	Date/Month		
Rate time RAT		0 min	Date/Year		
			Summer/Wintertime	AUTO	

Basic parameter *PAR*

Controller version			Program PR	0	
max1 off ↓	75 °C	°C	max1 on ↑	70 °C	°C
max2 off ↓	75 °C	°C	max2 on ↑	70 °C	°C
max3 off ↓	65 °C	°C			
min1 on ↑	45 °C	°C	min1 off ↓	40 °C	°C
min2 on ↑	65 °C	°C	min2 off ↓	60 °C	°C
min3 on ↑	40 °C	°C			
diff1 on ↑	8 K	K	diff1 off ↓	4 K	K
diff2 on ↑	8 K	K	diff2 off ↓	4 K	K
TEMP +10	40°C	°C	TEMP -20	60°C	°C
R RISE RR	0,60				
PREmax	70°C	°C	PREmin	30°C	°C
OTF	5°C	°C	RTF	5°C	°C
Output 1O	AUTO		Output 2+3 M	AUTO	
Control output C1	AUTO		Control output C2	AUTO	

Sensor type *SENSOR*

Sensor S1	RPT		Average determ. AV 1	1,0 s	s
Sensor S2	PT1000		Average determ. AV 2	1,0 s	s
Sensor S3	PT1000		Average determ. AV 3	1,0 s	s
Sensor S4	PT1000		Average determ. AV 4	1,0 s	s
Sensor S5	PT1000		Average determ. AV 5	1,0 s	s
Sensor S6	PT1000		Average determ. AV 6	1,0 s	s
S6 = VSG ⇒ LPP	0,5				

Mixer settings *MIXER*

OT/FV REG	OT REG		Room influence RI	50%	%
Increase switch-on power ISO	0%	%	Mixer run time RT	3,0min	min
Mean time AVT	10 min	min			

	FS	CS		FS	CS
Heating pump PUMP					
Room temperature switch off RT OFF	OFF		Hysteresis HYS	0,5K	K
Set flow temperature switch off PN< PM	OFF		Hysteresis HYS	2,0K	K
Outdoor temperature switch off heating mode OTNOFF	ON		Hysteresis HYS	2,0K	K
Nom. value outdoor temperature NV	18°C	°C	Mean time AVT	30min	min
Outdoor temperature switch off lowering mode OTLOFF	OFF		Hysteresis HYS	2,0K	K
Nom. value outdoor temperature NV	5°C	°C	Mixer behaviour M BEH	CLOSE	

Pump speed control PSC					
Abs.value control. AC	--		Desired value DVA	50°C	°C
Differential control DC	--		Desired value DVD	10 K	K
Event control EC	--		Threshold value TVE	60°C	°C
			Desired value DVE	130°C	°C
Waveform	WAVEP				
Proportional part PRO	5		Integral part INT	0	
Differential part DIF	0				
Minimum speed MIN	0		Maximum speed MAX	30	
Delay time ALV	0				

Control output 0-10V / PWM COP					
Control output COP 1					
OFF/5V/0-10V/PWM	OFF		Outputs OP	--	
Abs.value control. AC	--		Desired value DVA	50°C	°C
Differential control DC	--		Desired value DVD	10 K	K
Event control EC	--		Threshold value TVE	60°C	°C
			Desired value DVE	130°C	°C
Proportional part PRO	5		Integral part INT	0	
Differential part DIF	0		Output mode	0-100	
Min. analogue stage MIN	0		Max. analogue stage MAX	100	
Control output COP 2					
OFF/5V/0-10V/PWM	OFF		Outputs OP	--	
Abs.value control. AC	--		Desired value DVA	50°C	°C
Differential control DC	--		Desired value DVD	10 K	K
Event control EC	--		Threshold value TVE	60°C	°C
			Desired value DVE	130°C	°C
Proportional part PRO	5		Integral part INT	0	
Differential part DIF	0		Output mode	0-100	
Min. analogue stage MIN	0		Max. analogue stage MAX	100	

	FS	CS		FS	CS
Heat meter HQC					
Heat meter HQC 1					
ON/OFF	OFF				
Feed SSL	S4		Return SRL	S5	
Volume flow encoder VSG	--		or Volume flow V	50 l/h	l/h
Outputs OP	--				
Share of antifreeze SA	0%	%			
Heat meter HQC 2					
ON/OFF	OFF				
Feed SSL	S4		Return SRL	S5	
Volume flow encoder VSG	--		or Volume flow V	50 l/h	l/h
Outputs OP	--				
Share of antifreeze SA	0%	%			
Heat meter HQC 3					
ON/OFF	OFF				
Feed SSL	S4		Return SRL	S5	
Volume flow encoder VSG	--		or Volume flow V	50 l/h	l/h
Outputs OP	--				
Share of antifreeze SA	0%	%			

External sensors EXT DL					
External sensor E1	--		External sensor E2	--	
External sensor E3	--		External sensor E4	--	
External sensor E5	--		External sensor E6	--	
External sensor E7	--		External sensor E8	--	
External sensor E9	--		External sensor E9	--	

Information on the Eco-design Directive 2009/125/EC

Product	Class ^{1, 2}	Energy efficiency ³	Standby max. [W]	Typ. power consumption [W] ⁴	Max. power consumption [W] ⁴
UVR63-H ⁵	max. 6	max. 4	1.8	1.49 / 2.37	1.8 / 2.8

¹Definitions according to Official Journal of the European Union C 207 dated 03/07/2014

² The classification applied is based on optimum utilisation and correct application of the products. The actual applicable class may differ from the classification applied.

³ Contribution of the temperature controller to seasonal central heating efficiency in percent, rounded to one decimal place

⁴ No output active = standby / all outputs and the display active

⁵ The class is defined on the basis of the programming of the heating circuit controller, in accordance with the Ecodesign Directive.

Technical data

- Power supply:** 210 ... 250V~ 50-60 Hz
- Power input:** max. 3 VA
- Fuse:** 3.15 A fast-acting (device + output)
- Supply cable:** 3x 1mm² H05VV-F conforming to EN 60730-1
- Case:** plastic: ABS, flame resistance: Class V0 to UL94 Norm
- Protection rating:** II - safety insulated 
- Protection class:** IP40
- Dimensions (W/H/D):** 152x101x48 mm
- Weight:** 210 g
- Allowed ambient temperature:** 0 to 45° C
- 6 inputs:** 6 inputs- optional for temperature sensor (KTY (2 kΩ), PT1000), radiation sensor as digital input, or as pulse input for volume flow encoder (only input 6)
- 3 outputs:** output A1 Triac output (minimum load of 20W required)
output A2 Relay output
output A3 Relay output
- Rated current load:** Output 1: max. 1.5 A ohmic inductive cos phi 0.6
Output 2 and 3: max. 2.5 A ohmic inductive cos phi 0.6
- 2 control outputs:** 0 - 10V / 20mA switchable to PWM (10V / 500 Hz), supply +5 V DC / 10 mA or connection of the auxiliary relay HIREL-STAG
- Cylinder sensor BF:** diameter 6 mm incl. 2 m cable
BF PT1000 – to 90°C continuous load
BF KTY – to 90°C continuous load
- Boiler sensor KE:** diameter 6 mm incl. 2 m cable
KE PT1000 – to 160°C continuous load (momentary to 180°C)
KE KTY – to 160°C continuous load
- The sensor lines on the inputs having a cross-section of 0.50 mm² can be extended to a length of 50 m.
- Consumers (e.g.: pumps, valves...) having a cable cross-section of 0.75 mm² can be connected at a distance of up to 30 m.
- Differential temperature:** adjustable from 0 to 99°C
- Minimum threshold / Maximum threshold:** adjustable from -20 to 149°C
- Temperature display:** -40 to 140°C
- Resolution:** from -40 to 99.9°C in 0.1°C increments; from 100 to 140°C in 1°C increments
- Accuracy:** Accuracy: type +/-0.3%.

We reserve the right to make technical changes.

© 2016

EU Declaration of conformity

Document- Nr. / Date: TA17002 / 02/02/2017
Company / Manufacturer: Technische Alternative RT GmbH
Address: A- 3872 Amaliendorf, Langestraße 124

This declaration of conformity is issued under the sole responsibility of the manufacturer.

Product name: UVR63H
Product brand: Technische Alternative RT GmbH
Product description: Universal heating controller

The object of the declaration described above is in conformity with Directives:

2014/35/EU Low voltage standard
2014/30/EU Electromagnetic compatibility
2011/65/EU RoHS Restriction of the use of certain hazardous substances
2009/125/EC Eco-design directive

Employed standards:

EN 60730-1: 2011 Automatic electrical controls for household and similar use –
Part 1: General requirements
EN 61000-6-3: 2007 Electromagnetic compatibility (EMC) - Part 6-3: Generic standards -
+A1: 2011 Emission standard for residential, commercial and light-industrial envi-
+ AC2012 ronments
EN 61000-6-2: 2005 Electromagnetic compatibility (EMC) - Part 6-2: Generic standards -
+ AC2005 Immunity for industrial environments
EN 50581: 2012 Technical documentation for the assessment of electrical and electronic
products with respect to the restriction of hazardous substances

Position of CE - label: On packaging, manual and type label



Issuer: Technische Alternative RT GmbH
A- 3872 Amaliendorf, Langestraße 124

This declaration is submitted by

A handwritten signature in black ink, appearing to read 'Schneider Andreas'. The signature is written in a cursive, flowing style.

Dipl.-Ing. Andreas Schneider, General manager,
02/02/2017

This declaration certifies the agreement with the named standards, contains however no warranty of characteristics.

The security advices of included product documents are to be considered.

Guarantee conditions

Note: The following guarantee conditions do not in any way limit the legal right to a guarantee, rather expand your rights as a consumer.

1. The company Technische Alternative RT GmbH provides a two-year guarantee from the date of purchase by the end consumer for all the devices and parts which it sells. Defects must be reported immediately upon detection and within the guarantee period. Technical support knows the correct solution for nearly all problems. In this respect, contacting us immediately will help to avoid unnecessary expense or effort in troubleshooting.
2. The guarantee includes the free of charge repair (but not the cost of on site fault-finding, removal, refitting and shipping) of operational and material defects which impair operation. In the event that a repair is not, for reasons of cost, worthwhile according to the assessment of Technische Alternative, the goods will be replaced.
3. Not included is damage resulting from the effects of overvoltage or abnormal ambient conditions. Likewise, no guarantee liability can be accepted if the device defect is due to: transport damage for which we are not responsible, incorrect installation and assembly, incorrect use, non-observance of operating and installation instructions or incorrect maintenance.
4. The guarantee claim will expire if repairs or actions are carried out by persons who are not authorised to do so or have not been so authorised by us or if our devices are operated with spare, supplementary or accessory parts which are not considered to be original parts.
5. The defective parts must be sent to our factory with an enclosed copy of the proof of purchase and a precise description of the defect. Processing is accelerated if an RMA number is applied for via our home page www.ta.co.at. A prior clarification of the defect with our technical support is necessary.
6. Services provided under guarantee result neither in an extension of the guarantee period nor in a resetting of the guarantee period. The guarantee period for fitted parts ends with the guarantee period of the whole device.
7. Extended or other claims, especially those for compensation for damage other than to the device itself are, insofar as a liability is not legally required, excluded.

Legal notice

These assembly and operating instructions are protected by copyright.

Use outside the copyright requires the consent of the company Technische Alternative RT GmbH.

This applies in particular to reproductions, translations and electronic media.

Technische Alternative RT GmbH

A-3872 Amaliendorf Langestraße 124

Tel ++43 (0)2862 53635

E-Mail: mail@ta.co.at

Fax ++43 (0)2862 53635 7

--- www.ta.co.at ---



© 2017