



Supplementary instructions manual UVR1611E-NM/NP

Contents:

General information	1
Terminal connection diagram UVR1611-E.....	3
Schematic diagram of the special connections	4
Special connections: 1 - 5 of the terminal connection diagram	5
Programming terminal block 6, ribbon cables 7/8, mains connection 9 - 11	6
Input and output terminals	7
Connection diagram of the operating unit UVR1611E-DE	7
Technical data	8
Dimensions	8

General information

This data sheet is a supplement to the manual for the freely programmable universal controller UVR 1611 and describes the differences and additional functions of the special version UVR1611E in comparison with the standard unit (UVR1611K or UVR1611S).

Standard units and UVR1611E units use the same operating system. The function data (configuration) are compatible, hence the controller UVR1611E can likewise be programmed using the program TAPPS.

The UVR1611E is intended for control cabinet fitting and has the following described connections and functions in accordance with the allocation plan (pages 4/5) and customer-specific allocations (e.g. current sensors).

UVR 1611E-NM + UVR1611E-DE

The UVR1611E-NM power unit only forms a complete controller in conjunction with the UVR1611E-DE operating unit. **A corresponding operating unit is necessary for each power unit.** The operating unit only permits access to the corresponding power unit. The CAN monitor or the CAN-TOUCH serve as a global operating unit, with which access to several controllers is possible.

UVR1611E-NP

In contrast to the variant UVR1611E-NM+DE, this version, with an already integrated processor module with no operating option, represents a complete control unit. **Programming can only be carried out via a BL-NET.** The operation and visualisation of one or more units is possible using a CAN-Monitor, CAN-TOUCH or BL-NET (network – PC). Hence a system can be implemented with several UVR1611E-NP units and a single operating unit (e.g. CAN-MT).



**Power unit
UVR 1611 E-NM**



**Operating unit
UVR 1611E-DE**



**Power unit
UVR 1611E-NP
with processor
module**

Schematic diagram of the special connections

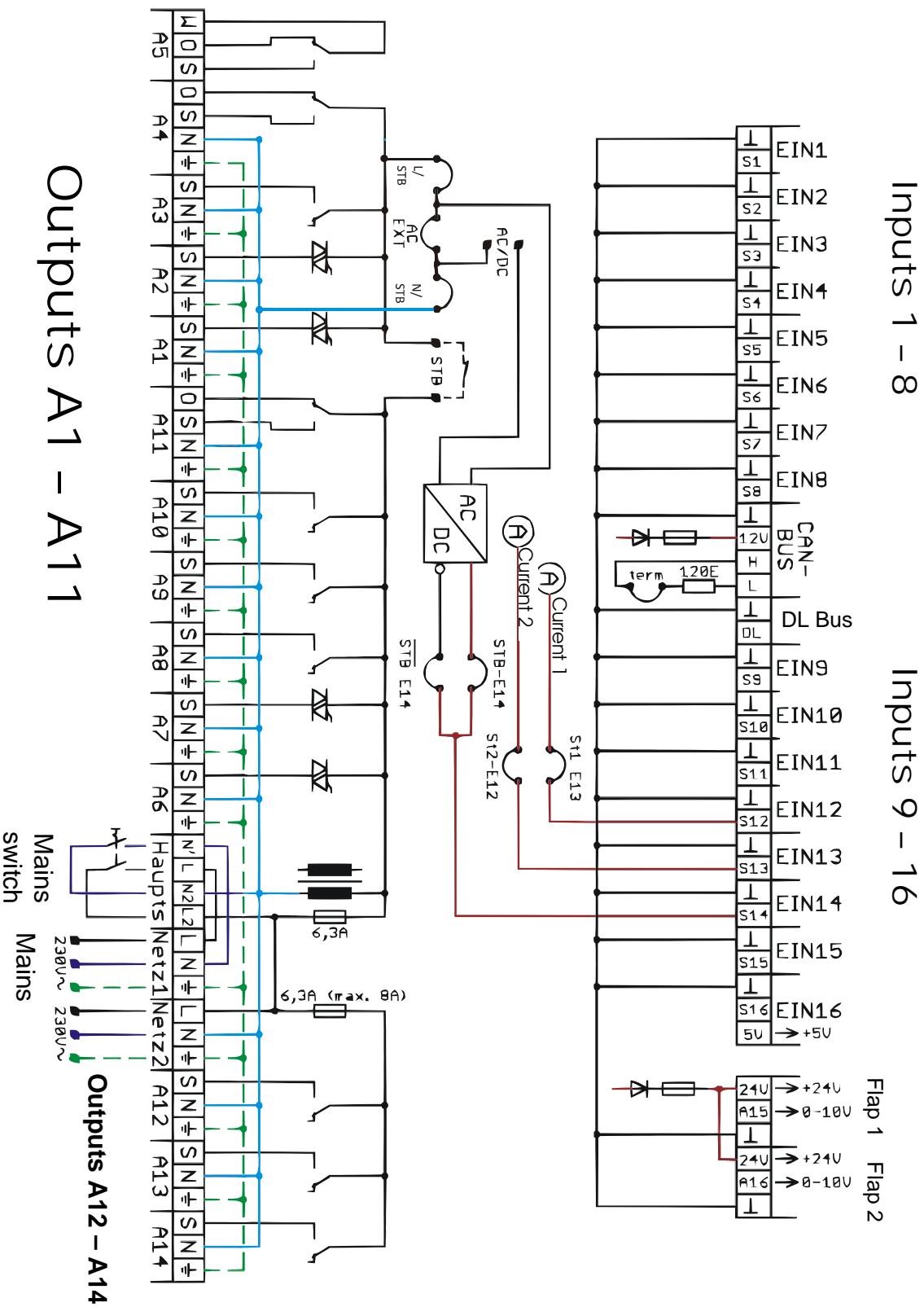

Special connections: 1 - 5 of the terminal connection diagram

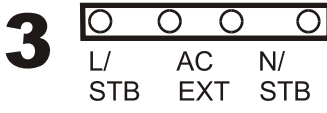
<p>1,2</p>	<p>Current sensors (only fitted upon customer request):</p> <p>The switched conductor of the mains connection to be used for current measurement must be fed to the required sensor before the clamp.</p> <p>In addition, the measurement signal must still be connected via the programming terminal block 6 with a control input.</p> <p>The corresponding input (12 or 13) must be parameterised as an analog input using the measured variable "Voltage" and the process variable "dim.less".</p> <p>Scaling (1V corresponds to 2A): 0,00V : 0 5.00V : 100 (= 10.0 A)</p> <p>Currents up to a max. 10A can be measured.</p> <p>The metering of electrical energy in the UVR1611E is not possible using current sensors.</p>								
<p>3</p>	<p>Plan view of the programming terminal block 3 on the PCB:</p> <div style="text-align: center;">  <p>3</p> <table style="margin-left: auto; margin-right: auto;"> <tr> <td style="border: 1px solid black; border-radius: 50%; width: 15px; height: 15px; display: inline-block;"></td> <td style="border: 1px solid black; border-radius: 50%; width: 15px; height: 15px; display: inline-block;"></td> <td style="border: 1px solid black; border-radius: 50%; width: 15px; height: 15px; display: inline-block;"></td> <td style="border: 1px solid black; border-radius: 50%; width: 15px; height: 15px; display: inline-block;"></td> </tr> <tr> <td>L/ STB</td> <td>AC EXT</td> <td>N/ STB</td> <td></td> </tr> </table> </div> <p>Programming terminal block for STB detection:</p> <p>STB = Safety temperature limiter with potential-free contact, which is closed in normal operation.</p> <p>The jumpers N/STB and L/STB are used to isolate the STB of the connection 5 via a detection circuit for further processing via the programming terminal block 6. Simultaneously, the jumper (plugged in the factory on to the STB connection 5) must be plugged onto the connection 4 (AC/DC).</p> <p>If the position AC/EXT is jumpered, the 230V~ connection 4 is applied via the detection circuit for further processing to the programming terminal block 6. In this case, forwarding of the STB signal to the programming terminal block is not possible.</p>					L/ STB	AC EXT	N/ STB	
L/ STB	AC EXT	N/ STB							
<p>4</p>	<p>AC/DC - conversion input to measure an external 230VAC signal instead of the STB signal. To do this the jumper AC/EXT must be plugged on to the programming terminal block 3, so that the 230V~ connection 4 is applied via the detection circuit for further processing on the programming terminal block 6. If the jumpers N/STB and L/STB (3) are not plugged over onto AC/EXT, the circuit board may be destroyed!</p>								
<p>5</p>	<p>STB connection: If an STB (safety temperature limiter) is connected to both these terminals, then in the event of a safety shutdown, the outputs A1 to A4 are placed in a zero volts state. In addition, this state can be detected by the controller (see 3 and 6). Without an STB it is essential that a jumper is placed at connection 5, so that the outputs A1 to A4 are supplied with voltage.</p>								

Programming terminal block 6, ribbon cables 7/8, mains connection 9 - 11

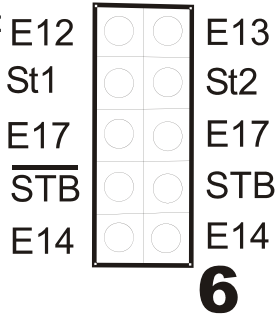
<p>6</p>	<p>Plan view of the programming terminal block 6 on the PCB:</p> 
	<p>Programming terminal block: All special signals, which this electronic unit provides in addition to a standard UVR1611 control can be routed to normal 1611 sensor inputs with the aid of this terminal block and jumpers.</p> <p>E12/St1 The current measurement 1 is routed to input 12</p> <p>E13/St2 The current measurement 2 is routed to input 13</p> <p>E17 Special controller input (currently not yet functional)</p> <p>E14/$\overline{\text{STB}}$ The voltage identification from 4 or 5 is applied to input 14 in inverted state. When a voltage is applied (e.g. STB closed/normal operation), the controller measures a digital signal "OFF" or the measurement of a sensor connected to E14. Without a voltage (e.g. STB open/fault) the controller detects a digital signal "ON" or -999°C at E14.</p> <p>E14/STB The voltage identification from 4 or 5 is applied to input 14 in normal state. With an applied voltage (e.g. STB closed/normal operation) the controller detects a digital signal "ON" or -999°C at E14. With no applied voltage (e.g. STB open/fault) the controller measures a digital signal "OFF" or the measurement of a sensor connected to E14.</p>
<p>7 + 8</p>	<p>2 14-conductor ribbon cables to the operating unit:</p> <p>The two ribbon cables are glued together in the factory. The connections to the PCB are non-interchangeable. The cables are already plugged in to the operating unit (running parallel, outgoing upwards).</p> <p>Cable length: approx. 50cm</p>
<p>9</p>	<p>Mains 2: Direct mains connection 230VAC without mains switch</p>
<p>10</p>	<p>Mains 1: Mains power connection for external mains switch (11)</p>
<p>11</p>	<p>Connection of the external two-conductor mains switch, which switches the electrical connection from Mains1 (10) through to the completely internal voltage distribution (also Mains2 = 9).</p>

Input and output terminals

Protective low voltage side (EIN = IN):

The inputs **EIN 1** to **16** technically correspond to the normal UVR1611 inputs.

The connection **EIN 16** has an additional 5V supply connection for miscellaneous sensors such as the electronic volume flow encoder.

The two connections of the **0-10V/PWM outputs** have an additional **24V** supply connection for supplying flap valve motors. Therefore these slots are also labelled **Klappe1** (Flap1) and **Klappe2** (Flap2) and in total can be loaded with up to 3 Watt.

The slots to the **CAN bus** occupy the same sequence as for all CAN units with this connector system. **Termination** with a jumper must be carried out according to the CAN instructions (see UVR1611 manual).

Supply voltage side (AUS = OUT):

The output **AUS 1** is not suitable for control of relays or contactors, even if an RC member is used.

The outputs **AUS 2** to **11** technically correspond to the normal UVR1611 outputs.

AUS 1 to **4** only receive voltage, if the plug 5 (STB) is jumpered.

AUS 3/4, 8/9 and **10/11** are additionally equipped with a four-pin common slot for mixer applications.

The outputs **AUS 12, 13** and **14** have a shared slow-blow fuse for max. 8A for somewhat higher loads (each individual relay but only loadable to 3A).

Output **14** can simultaneously be used as a switching output **AUS 14** and **data link** (DL-bus). For activation, the output must be parameterized as a "Switch output", even if the data link is to be activated.

To activate the data link, the query "UVR1611E:" must also be answered "yes" (see UVR1611 manual).

Connection diagram of the operating unit UVR1611E-DE

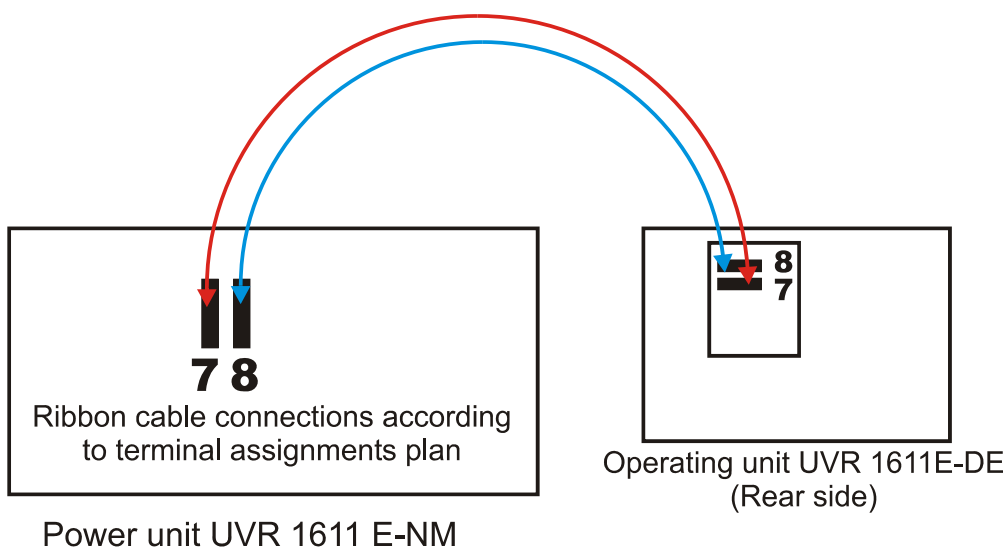

Technical data

Fuse: 6.3 A fast-acting (outputs 12, 13, 14 extra protection - factory fitted: 6.3A fast-acting)

All other technical data correspond to the UVR1611 standard version

Dimensions of the operating unit in mm:

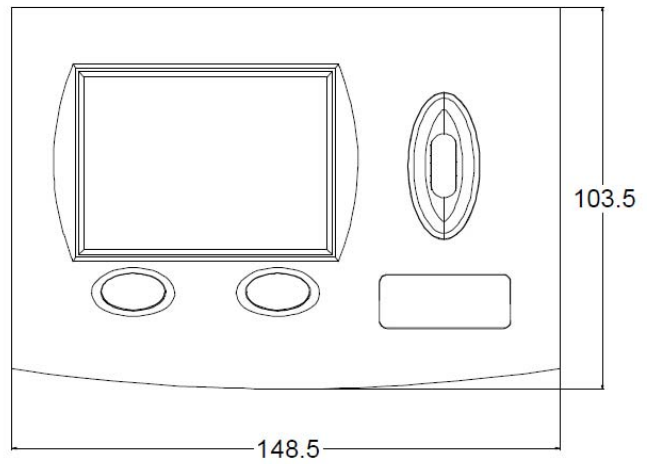
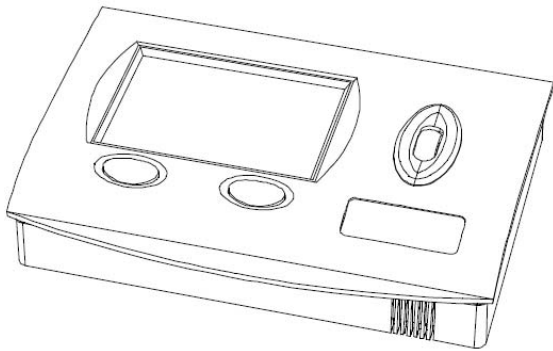
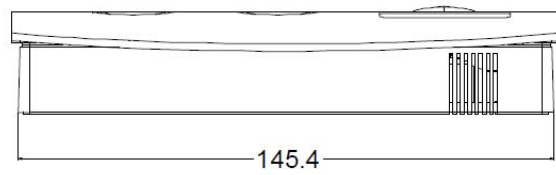
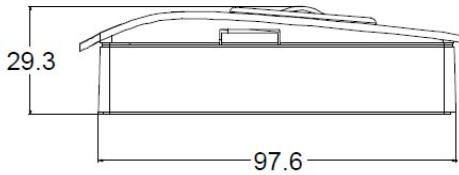

Dimensions of the power unit
in mm:

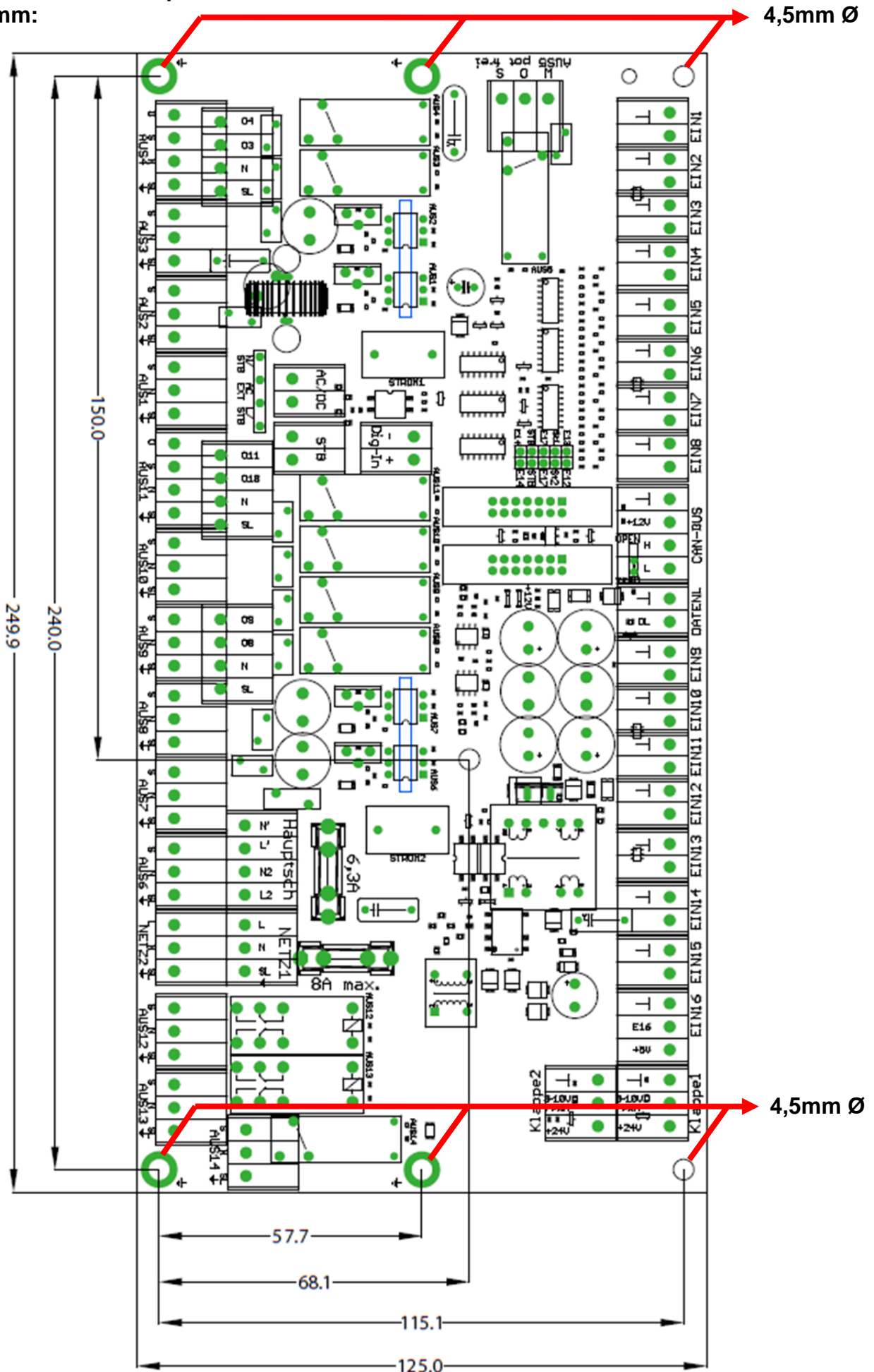

We reserve the right to make technical changes

© 2013

TECHNISCHE ALTERNATIVE



elektronische Steuerungsgerätegesellschaft m. b. H.

A-3872 Amaliendorf Langestraße 124

Tel +43 (0)2862 53635

Fax +43 (0)2862 53635 7

E-Mail: mail@ta.co.at

--- www.ta.co.at ---

© 2013