



GEBÄUDETECHNIK  
INTELLIGENT  
GEREGELT

ta.co.at

# FRISTAR3

## FRESH WATER STATION

---



## Operating manual



# Table of contents

<b>Safety instructions</b> .....	<b>4</b>
Disposal .....	4
<b>Mode of operation</b> .....	<b>5</b>
Hydraulic circuit diagram .....	5
<b>Components</b> .....	<b>6</b>
<b>Installation</b> .....	<b>7</b>
Preparation .....	7
Special accessories: VMS pre-mixing set .....	7
Dimensions .....	8
Interchanging connections .....	9
Installation .....	10
<b>Commissioning</b> .....	<b>10</b>
<b>Connection of a circulation line</b> .....	<b>11</b>
Activating the DHW circulation pump using the FRISTAR3 controller .....	11
Hydraulic circuit diagram with circulation line .....	11
Circulation pump (optional) .....	11
Activating the DHW circulation pump using a different switching device .....	11
<b>Cascade switching</b> .....	<b>12</b>
Hydraulic circuit diagram of a cascade with four FRISTAR3 fresh water stations .....	12
Control with UVR67 .....	13
Control of cascade switching with freely programmable controllers .....	14
Cascade switching with circulation line .....	14
Schematic diagram for activating the DHW circulation pump with the FRISTAR3 controller .....	14
Schematic diagram for activating the DHW circulation pump with a different switching device .....	15
<b>Data transfer with CORA-DL</b> .....	<b>16</b>
Input variables .....	16
Output variables .....	16
Status .....	17
DL bus .....	17
Index .....	18
DL inputs .....	18
DL outputs .....	18
For UVR67 .....	18
<b>Electrical connection</b> .....	<b>19</b>
Safety instructions .....	19
<b>Operation of the controller and LED indicators</b> .....	<b>20</b>
Manual-automatic changeover switch .....	20
Emergency operation mode .....	20
LED status displays .....	21
<b>Technical data</b> .....	<b>22</b>
Pressure loss characteristic curve plate heat exchanger .....	23
Pump curve .....	23
Information on the Eco-design Directive 2009/125/EC .....	24
Plate heat exchanger corrosion resistance .....	24
<b>Tips on troubleshooting</b> .....	<b>25</b>

# Safety instructions



**These instructions are intended exclusively for authorised professionals. To avoid accidents and damage due to incorrect operation, carefully read through these operating instructions before you start working with the freshwater station. If you carry out any alterations to the construction of the freshwater station or the safety devices, you may invalidate your right to make guarantee claims. Always observe the local regulations.**

## Intended use

The freshwater station may only be installed in heating systems between the buffer tank and the drinking water circuit. The technical limit values specified in this manual must be considered.

Incorrect use will result in the negation of any liability claims.

## Electrical connection

Any electrical connections must be made by qualified electricians. Connection cables must be routed in the recesses provided in the insulated base in such a way that direct contact with the pump casing and the pipes is prevented.

Before switching on, check whether the supply voltage matches that stated on the power rating plates of the pump and the controller. All connections must correspond to the local regulations. Before opening the controller, all poles of the power supply must be isolated.

If you are connecting the FRISTAR3 to an electrical system via a residual current device (RCD), use an RCD of type A which will detect pulsating direct currents and bears the following marking:

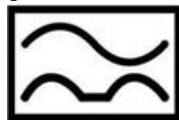

Checking using a high voltage insulation tester may cause damage to the pump and the control electronics.

## Safety standards during installation, commissioning and maintenance

Installation, commissioning and maintenance may only be carried out by qualified persons who are familiar with these operating instructions.

Before you start work on the system, ensure that the system is switched off and all components are cooled down. When replacing the pump, turn the 4 ball valves into the closed position.

In multi-occupancy dwellings, legionella protection must be observed in accordance with the local regulations.



**WARNING! Dependent on the pump and system operating conditions, the surface temperatures can be very high. Direct contact with the pump or pipes can result in burns!**

## Disposal

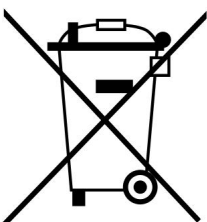

- Devices no longer in use or beyond a state of repair must be disposed of in an environmentally responsible manner by an authorised collection point. They must never be treated as ordinary household waste.

- We can undertake the environmentally responsible disposal of devices sold by the Technischen Alternative company upon request.

- Packaging material must be disposed of in an environmentally responsible manner.

- Incorrect disposal may result in considerable damage to the environment, as many of the materials used require professional handling.

## Mode of operation

Through use of the instantaneous heating concept, drinking water is heated both hygienically and with low energy consumption in the **FRISTAR** freshwater station.

If water is drawn from the mains, the **primary circuit** pump transports tank water from a buffer tank through the plate heat exchanger.

On the **secondary side** of the heat exchanger the drinking water flowing through is heated to the set temperature. The cooled tank water is returned to bottom layer of the buffer tank.

The **speed control** of the primary circuit pump takes place in the FRISTAR3 controller based on the readings from the volume flow sensor in the hot water line (flow rate  $V_{WW}$  and temperature  $T_{WW}$ ) and the temperature sensors in the cold water line ( $T_{KW}$ ) and the primary flow ( $T_{Pri}$ ). The pump is controlled with PWM signals. Optimal matching of the control behaviour with the pump, valve and heat exchanger ensures perfect stabilisation of the outlet temperature.

The controller has an integral heat meter, which enables the values to be read via DL bus.

The controller automatically initiates anti-corrosion measures for the pump and valve. If the pump is not actuated for 7 days or the valve for one day (regardless of whether through automatic mode, manual mode or otherwise), that component is operated briefly. This takes place while ensuring that there is no DHW demand.

## Hydraulic circuit diagram

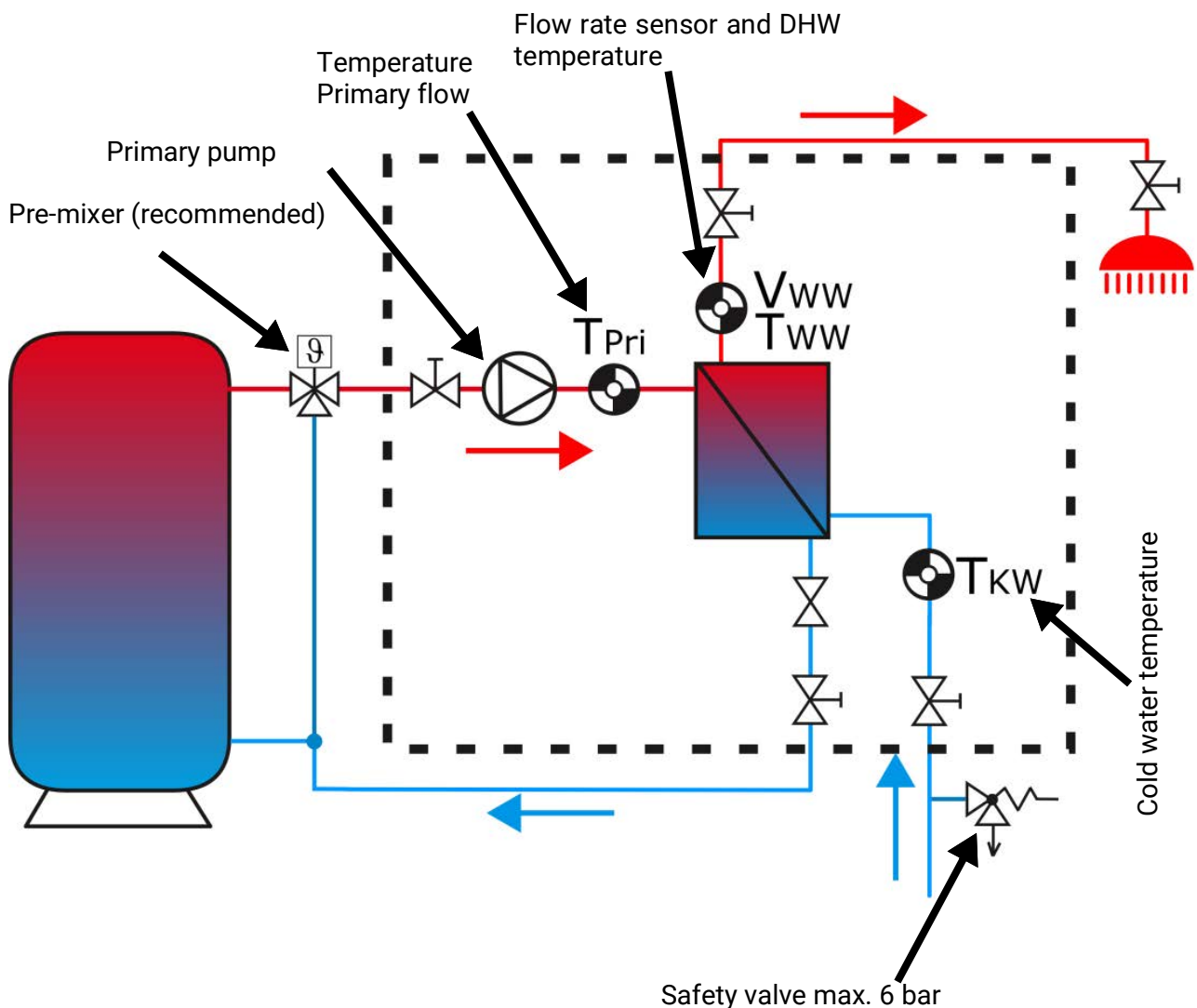

# Components

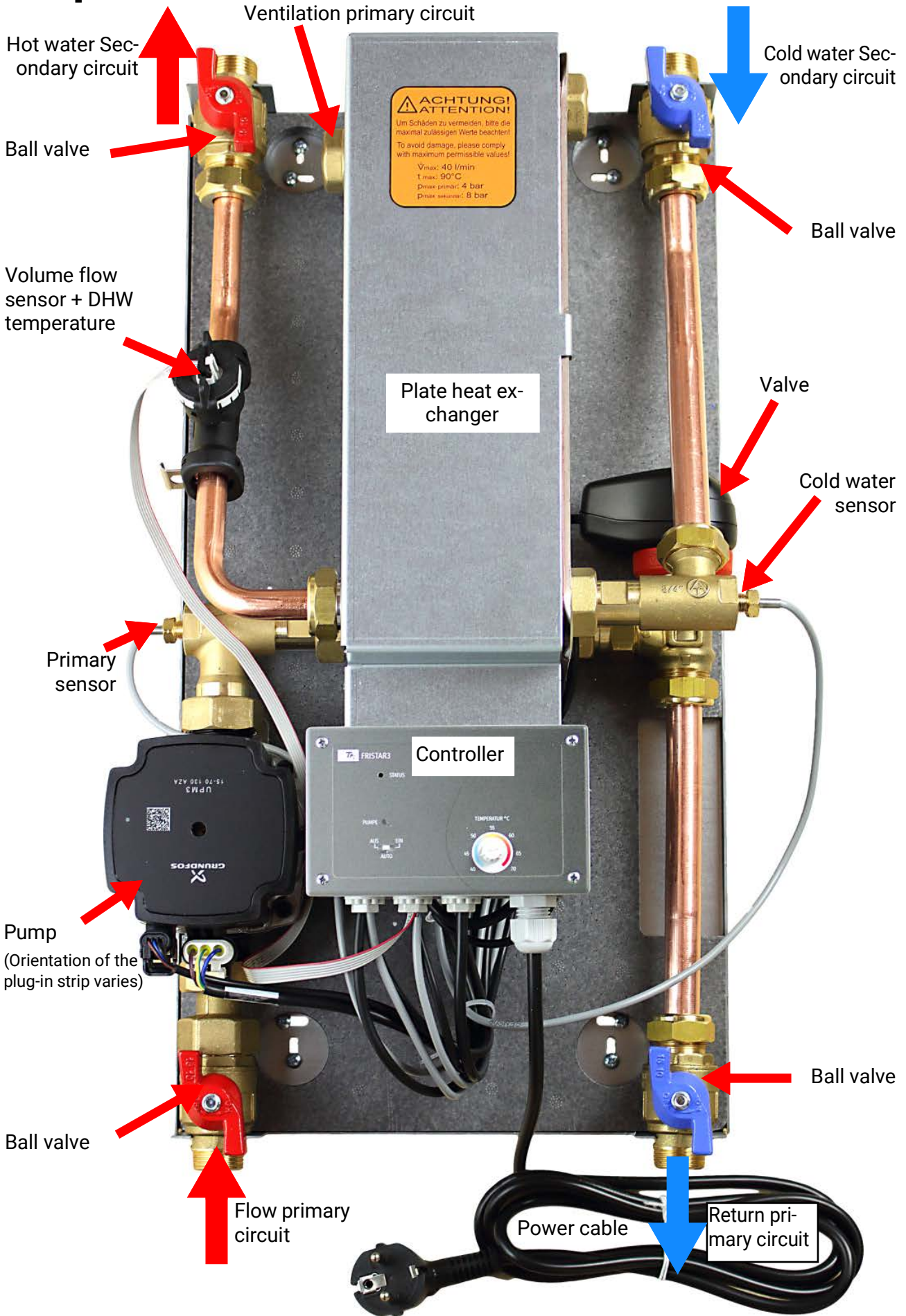

# Installation

## Preparation

- A **safety valve** (max. 6 bar) must be installed in the cold water supply corresponding to standards DIN 1988 and 4753, part 1 and TRD 721.
- If the cold water pressure > 6 bar, fit a **diaphragm pressure reducer** max. 6 bar.
- The installation of **flushing equipment** before and after the plate heat exchanger in the primary and secondary circuits is recommended for descaling or cleaning as necessary.

## Special accessories: VMS pre-mixing set

If the tank is operated at a temperature higher than 70 °C a **pre-mixer** that restricts the temperature to less than 70 °C must be used in the primary circuit.

In order to prevent damage from calcification, the maximum pre-mixing temperature must be 70 °C with a water hardness of up to 10 °dH, 65 °C with up to 15 °dH and 60 °C at most with a hardness above 15 °dH.

The **VMS** pre-mixing set is suitable for both FRISTAR models (left pump, right pump).

**Figure:** Connection for FRISTAR with **right pump**

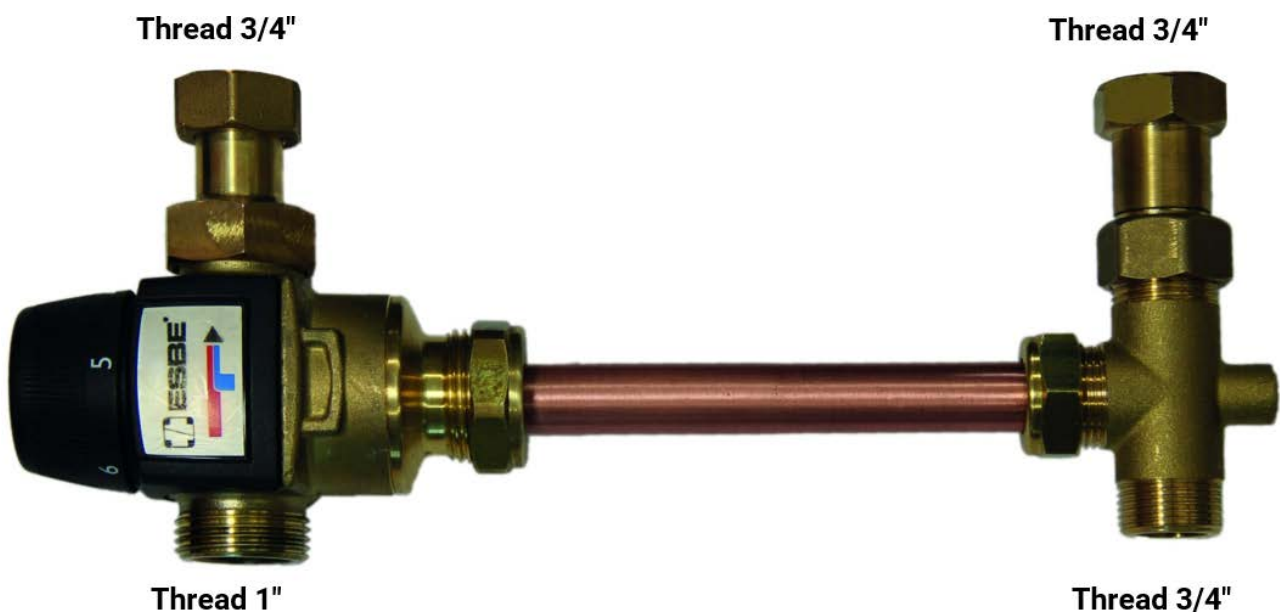

Technical data	
Maximum temperature of primary circuit	95°C, short term: 100°C
Setting range	45°C - 65°C
Flow coefficient of mixing valve	4,5m <sup>3</sup> /h
Connections for FRISTAR	¾"

# Dimensions

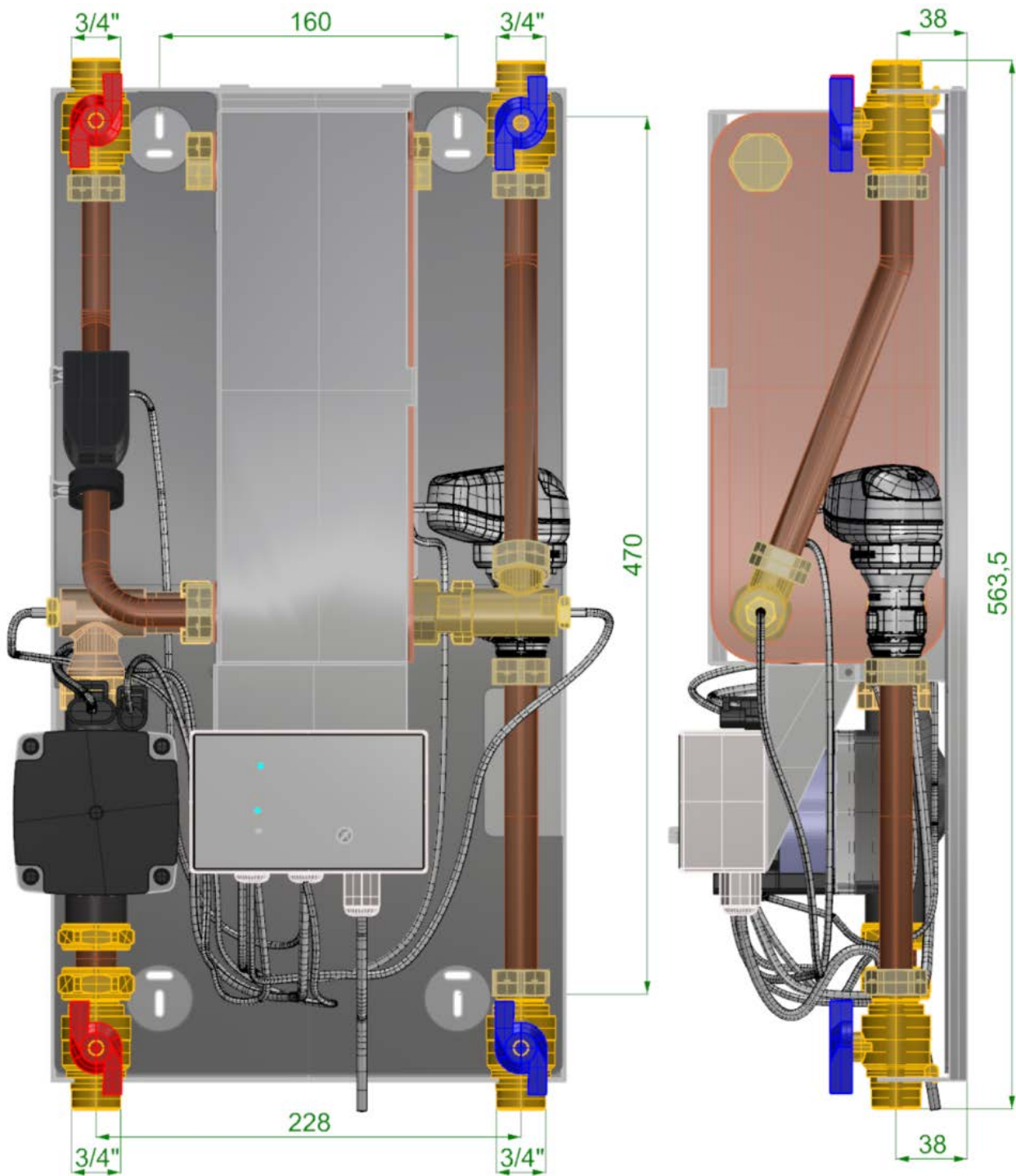

## Housing dimensions (thermal insulation cover)

W x H x D = 366 x 573 x 160 mm



# Interchanging connections

For optimum matching of the pipelines to the freshwater station it is possible to interchange the connections (right/left). This does not change venting of the primary circuit, however.

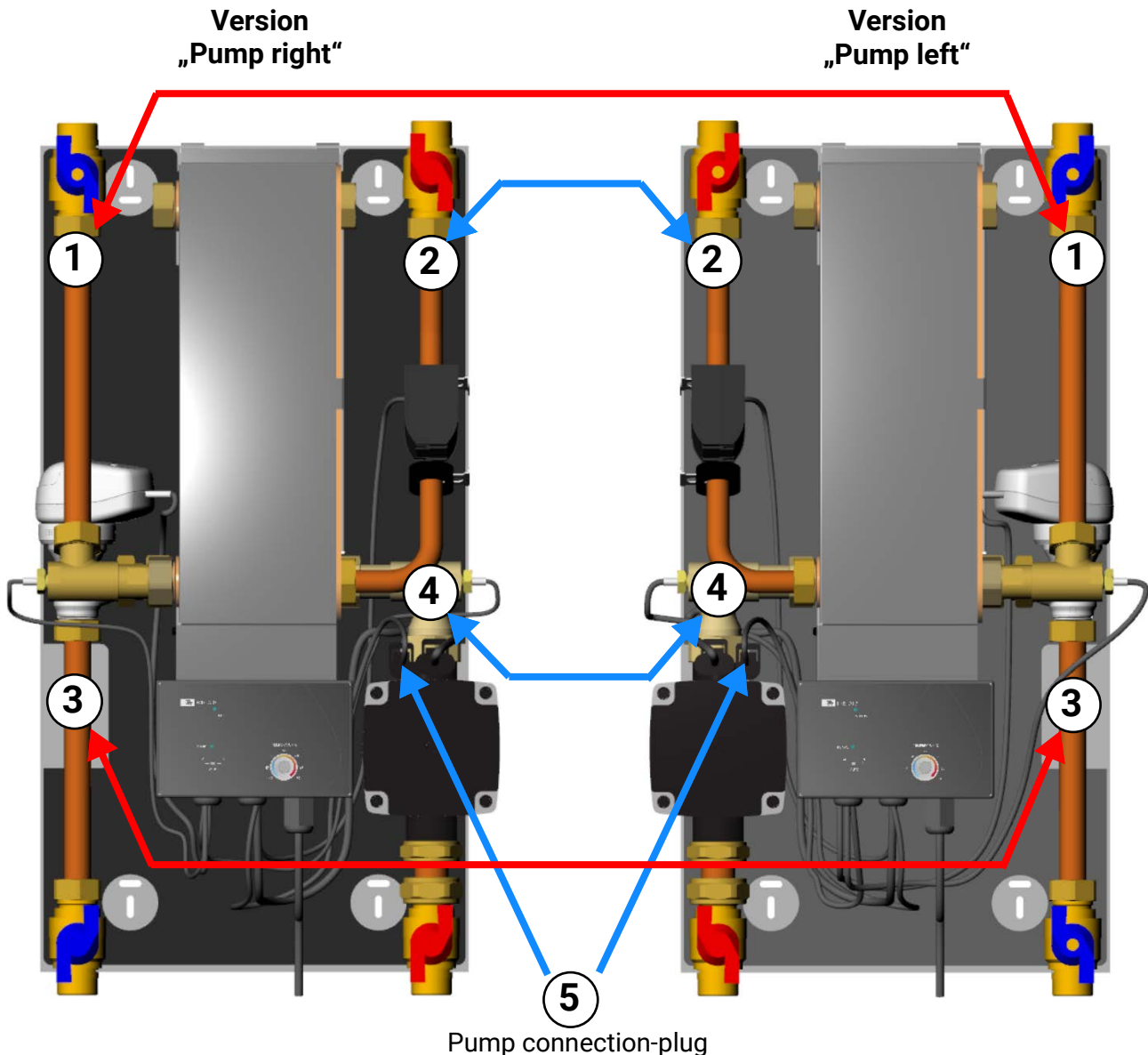

## Procedure:

1. Demounting of pipe elements 1 - 4 including pump from the heat exchanger
2. Removal of the pump and installation in the correct position.
3. Remount pump connection plug 5 on the other side. The flow direction of the pump is upwards. On WILLO pumps, the connection plug is above the pump, and on Grundfos pumps it is below.
4. Mounting of pipe elements 1 - 4 and the pump on the heat exchanger (see figures above) on the other side, correct positional setup of the volume flow sensor
5. Commissioning according to the "Commissioning" chapter

**Important:** The primary and secondary connections must be exchanged together!

## Installation

- Mounting position: Only **vertical**
- Installation with the heat exchanger at the top/above the controller (acc. to diagrams) is recommended.
- Pull off the cowling in a forwards direction.
- If necessary: Interchange the right/left connections (see chapter "Interchanging connections").
- Mark the fastening points, insert rawl plugs, fasten the station to the wall.
- Fitting and connection of the pipe connections (3/4" outside thread connector). Plan for as short as possible pipes in the primary circuit (tank -> freshwater station).
- **Check all the freshwater module's connections for leaks and ensure that they are securely fitted.**
- Electrical connection

The freshwater station is pre-wired ready for installation, connection to the electricity mains takes place on site:

- using a plug in a wall socket or
- using a double pole isolator with a permanent connection.

## Commissioning

- Before filling the system, thoroughly flush both the primary and secondary side systems.
- **Slowly** fill the house system with drinking water via the secondary side ball valves.
- Vent the house system at the draw-off valves.
- **Slowly** fill the system with hot water via the ball valves in the primary flow.
- Vent the primary circuit using the venting opening of the plate heat exchanger.
- Set the pump to continuous operation and check pump running. Audible background noise during operation of the circulating pump indicates air in the system.
- **Warning!** Only start the pump when it is filled.
- Check all connections, including in the freshwater station, for correct seating and leaktightness. If necessary, retighten to the necessary torque.
- When using a circulation pump: Set the differential temperature at the potentiometer inside the controller (Caution! Switch off the 230 V power supply before opening the controller!)
- Place the cowling on the bottom part
- Set the pump in automatic mode and select the setpoint temperature.

## Connection of a circulation line

### Activating the DHW circulation pump using the FRISTAR3 controller Hydraulic circuit diagram with circulation line

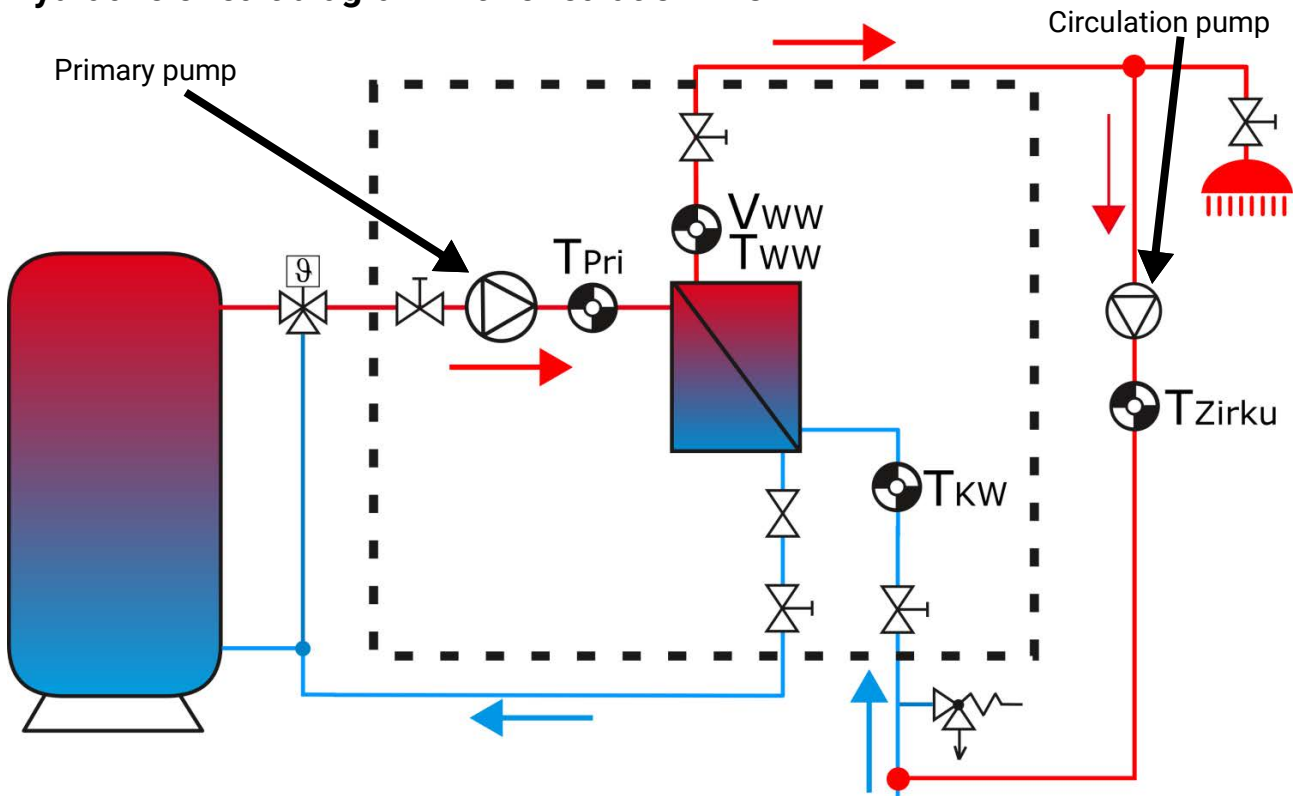

### Circulation pump (optional)

If an external DHW circulation pump is connected directly to the FRISTAR3 controller, it will operate in **pulse mode**. While water is being drawn off (once or continually), the DHW circulation pump runs until the temperature at sensor  $T_{Zirku}$  reaches the set temperature (potentiometer on the front of the controller) minus the set difference (potentiometer inside the controller) (no maximum runtime).

- When water is drawn off (set temp. via potentiometer), DHW circulation runs if:  $T_{Zirku} < \text{set temp.} - \text{differential}$
- For draw-off (if set DHW circulation temp. specified via DL/CORA-DL): absolute value according to input variable "Forced DHW circ." or index 3

If a DHW circulation pump is not used, the potentiometer must be set to 0 (= factory setting), as otherwise the primary pump would run on after every draw-off.

To connect the circulation line, a tee is installed in the secondary circuit cold water pipe.

A PT1000 sensor is used for the  $T_{Zirku}$  sensor.

The sensor  $T_{Zirku}$  is optional (including when using a DHW circulation pump), but is recommended for optimal functionality. If it is not connected, the temperature of the sensor  $T_{KW}$  is used. If the set temperature (minus the differential) is reached in this case (not using a  $T_{Zirku}$ ), pump operation is only permitted again after a pause of 10 minutes.

### Activating the DHW circulation pump using a different switching device

It must be ensured that the flow rate in the DHW circulation line is greater than the flow sensor minimum flow rate (2 l/min or 120 l/h).

When the DHW circulation pump is switched on, the  $V_{KW}$  sensor measures the flow rate and the primary pump is enabled.

## Cascade switching

The FRISTAR3 is designed for a maximum water draw-off of 30 l/min. For a greater draw-off of domestic hot water, multiple freshwater stations can be used in a cascade.

The first module is fed directly, all other stations are added with stop valves, if necessary. These valves must open or close in at least 30 seconds. The **UDV** universal 3-way valve from Technische Alternative is excellent for this purpose.

Valves are added via overriding controller with a volume flow sensor that measures the total volume flow. With up to 3 modules, the FTS5-85DL sensor is adequate; with 4-5 modules, the FTS9-150DL sensor must be used.

The sensors in the FRISTAR stations should not be subjected to more than 30 litres per minute. The final station, however, should be flushed several times a day to prevent stagnant water from forming. This is ensured if the overriding controller increases the station number in stages of about 8-10 l/min. In the following "step-by-step" instructions, the first stage with 9 l/min was selected because sensor FTS9-150DL is activated properly starting at 9 l/min only.

A UVR67 controller can be used for switching the modules. Cascade control can of course also be integrated into the programs of freely programmable controllers.

## Hydraulic circuit diagram of a cascade with four FRISTAR3 fresh water stations

Figure with fresh water stations version, version "Pump on the right"

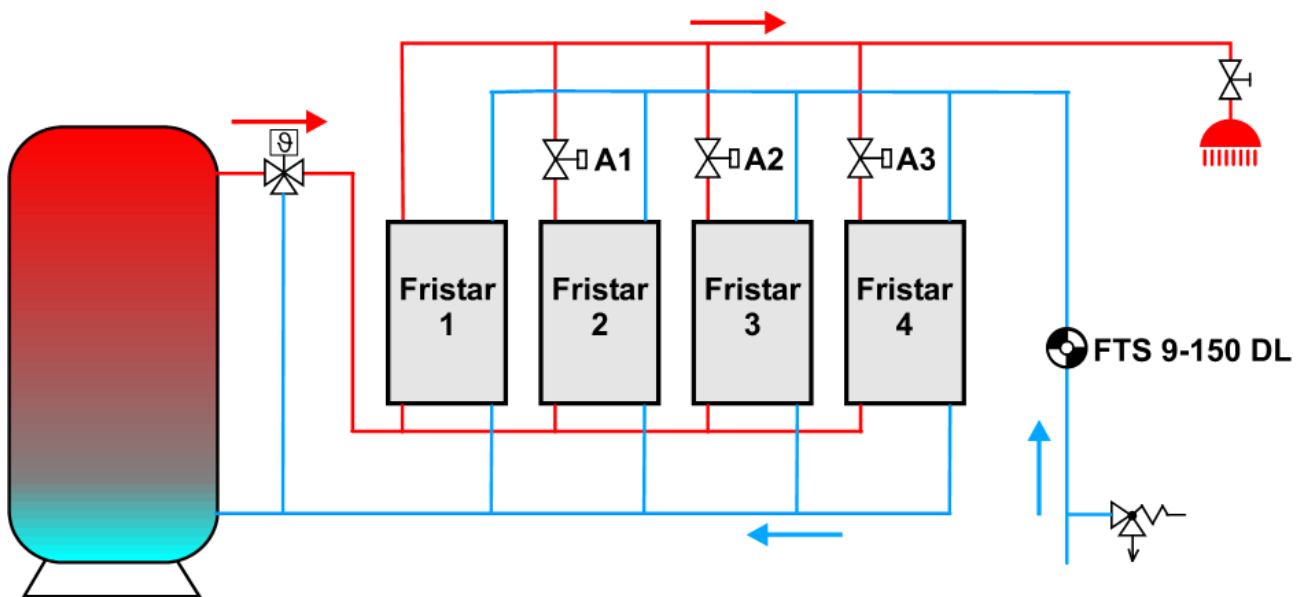

The initial designations for stop valves **A1 – A3** refer to controller UVR67.

# Control with UVR67

## Step-by-step instructions

	Level/menu		Technician menu password <b>32</b> , expert menu PW <b>64</b>
<b>1</b>	<b>Expert</b> Ext. sensors	DL bus address <input type="text" value="1"/> DL bus index <input type="text" value="2"/>	Adoption of the flow rate at sensor FTS9-150DL as EXT input 1. When using an FTS5-85DL, the DL bus index is specified as 7.
<b>2</b>	<b>Expert</b> Sensor menu → S1	Sensor <input type="text" value="Sensor accept"/> Sensor assignment <input type="text" value="Ext. sens. 1"/>	Adoption of EXT input 1 at sensor <b>S1</b> .
<b>3</b>	<b>Expert</b> Sensor menu → S3	Sensor <input type="text" value="Sensor accept"/> Sensor assignment <input type="text" value="Ext. sens. 1"/>	Adoption of EXT input 1 at sensor <b>S3</b> .
<b>4</b>	<b>Expert</b> Sensor menu → S4	Sensor <input type="text" value="Sensor accept"/> Sensor assignment <input type="text" value="Ext. sens. 1"/>	Adoption of EXT input 1 at sensor <b>S4</b> .
<b>5</b>	<b>Expert</b> System protection Excess temp. limiter 1	Enable <input type="text" value="No"/>	Deactivation of collector excess temperature shut-down activated at the factory.
<b>6</b>	<b>Expert</b> Program settings	Program <input type="text" value="496"/>	Selection of program <b>496</b> .
<b>7</b>	<b>Technician</b> Parameters	Max1 S2 <input type="text" value="No"/>	The values <b>Max1</b> , <b>Max2</b> and <b>Max3</b> must be set to "No". This eliminates their influence on the control process.
<b>8</b>	<b>Technician</b> Parameters	Min1 S1 On   Off Yes   54.0 °C   49.0 °C	The parameter <b>Min1</b> maintains its start threshold at <b>54.0 °C</b> ( $\cong$ 540 l/h = 9 l/min). The stop threshold is <b>49.0 °C</b> . These thresholds are used to switch output <b>A1</b> .
<b>9</b>	<b>Technician</b> Parameters	Min2 S3 On   Off Yes   96.0 °C   91.0 °C	Start value <b>96.0 °C</b> ( $\cong$ 960 l/h = 16 l/min) for the value <b>Min2</b> . The stop threshold is <b>91.0 °C</b> . These thresholds are used to switch output <b>A2</b> .
<b>10</b>	<b>Technician</b> Parameters	Min3 S3 On   Off Yes   144.0 °C   139.0 °C	Start value <b>144.0 °C</b> ( $\cong$ 1440 l/h = 24 l/min) for the value <b>Min3</b> . The stop threshold is <b>139.0 °C</b> . These thresholds are used to switch output <b>A3</b> .
<b>11</b>	<b>Technician</b> Parameters	Diff1 S1 - S2 <input type="text" value="No"/>	The values <b>Diff1</b> , <b>Diff2</b> and <b>Diff3</b> must be set to "No". This eliminates their influence on the control process

The 3 outputs **A1**, **A2** and **A3** for the shut-off valves are switched on if the corresponding flow rate thresholds **min1** (540 l/h), **min2** (960 l/h) and **min3** (1440 l/h) are exceeded.

## Control of cascade switching with freely programmable controllers

The outputs for the stop valves are switched on by comparison functions, with one comparison function for each valve. The relevant switch-on and switch-off thresholds should be chosen in the same way as for the UVR67.

## Cascade switching with circulation line

### Schematic diagram for activating the DHW circulation pump with the FRI-STAR3 controller

Figure with fresh water stations version, version "Pump on the right"

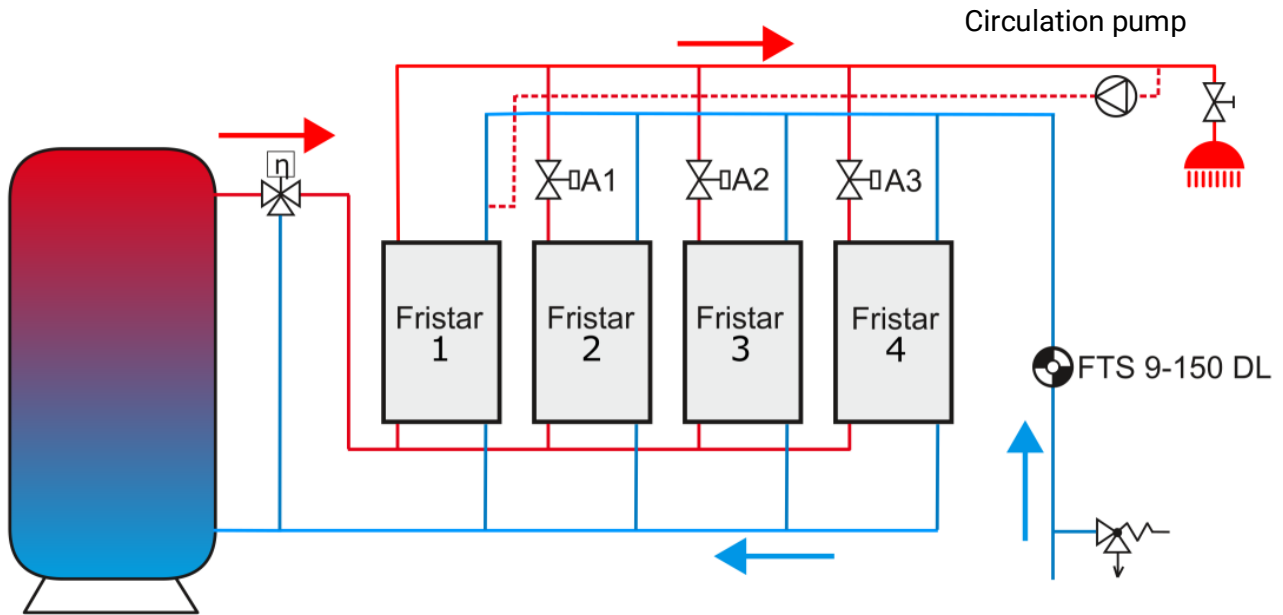

The circulation pump is connected only to the always ready **FRISTAR3**.

## Schematic diagram for activating the DHW circulation pump with a different switching device

If the DHW circulation pump is switched via a different controller, the DHW circulation return must be connected to the cold water supply line.

However, it must be ensured that the flow rate in the DHW circulation line is greater than the minimum flow rate of the flow sensor in the FRISTAR3 (2 l/min or 120 l/h).

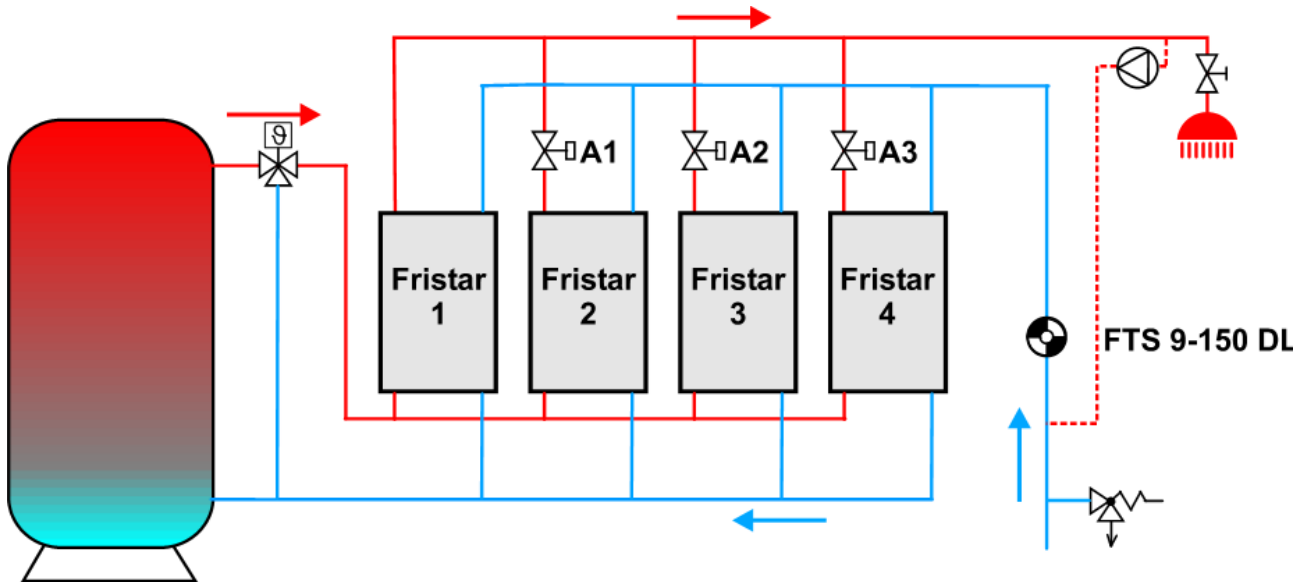

### UVR67

If the DHW circulation pump is also to be switched on and off **according to temperature**, the maximum possible number of FRISTAR3 modules is three. This is done using the program **480** for switching modules 2 and 3 on and off via outputs **A1** and **A2**. The DHW circulation pump can be switched at output **A3** via the differential **S5 – S4** (**S5** is unused, **S4** measures the DHW circulation temperature and switches off when the **max3** value is reached).

### Freely programmable controllers

The circulation pump can be controlled with the "**circulation**" function.

# Data transfer with CORA-DL

The FRISTAR3 controller has a connection for CORA-DL (electrical connection on page 19). This makes it possible to read out and preset various values. Datalogging of the values is also possible. To work with CORA-DL, the CORA device FRISTAR3 is used on the freely programmable controller.

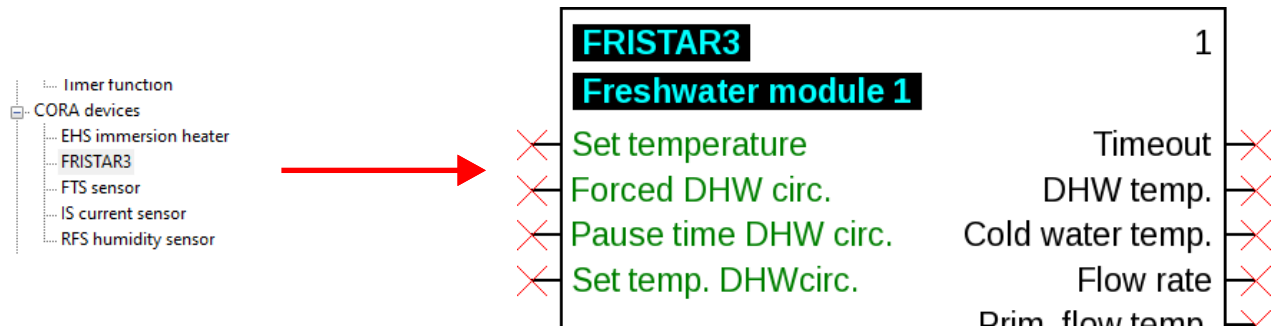

## Input variables

<b>Set temperature [°C]</b>	Overwrites the set temperature selected at the potentiometer
<b>Forced DHW circ. [On/Off]</b>	External switch on of the DHW circulation pump. When "ON", the DHW circulation pump runs continuously. When "OFF", automatic mode applies.
<b>Pause time DHW circ. [s]</b>	After DHW circulation has ended, it can only be restarted after this time has elapsed
<b>Set temp. DHW circ. [°C]</b>	Set temperature for DHW circulation measured at the DHW circulation sensor (if not used, the cold water sensor applies)

## Output variables

Some of these variables are hidden by default in TAPPS2.

<b>Timeout [Yes/No]</b>	Digital value <b>Yes/No</b> (Yes if connection lost)
<b>DHW temperature [°C]</b>	Temperature at sensor $T_{WW}$
<b>Cold water temp. [°C]</b>	Temperature at sensor $T_{KW}$
<b>Flow rate [l/h]</b>	Flow rate according to flow rate sensor
<b>Prim. flow temp. [°C]</b>	Prim. flow temp. [°C]
<b>DHW circ. return temp. [°C]</b>	Temperature of the optional DHW circulation sensor $T_{Zirku}$
<b>Eff. set temp. [°C]</b>	Display of the currently effective set temperature
<b>Pump rate [%]</b>	0-100 % output of the PWM pump
<b>Valve position [%]</b>	0 % = valve fully closed 100 % = valve fully open
<b>Output [kW]</b>	Instantaneous output of the freshwater module
<b>Energy meter rdg [kWh]</b>	Total energy meter reading
<b>Water meter rdg [m3]</b>	Total water meter reading
<b>Status code</b>	See „Status“ on page 17



## Status

A status code is assigned to each status. The sum of all active status codes is output under **index 13** ("Status").

1	Circulation pump running
2	DHW circulation, enable
16	Sensor T.DHW circ: open circuit
32	Sensor T.DHW circ: short circuit
64	Sensor T.DHW: open circuit
128	Sensor T.DHW: short circuit
256	Sensor T.cold water: open circuit
512	Sensor T.cold water: short circuit
1024	Sensor T.primary: open circuit
2048	Sensor T.primary: short circuit
4096	Pump fault
8192	Valve fault

**Example:** A status of **3** would mean that the DHW circulation pump is running (1) and the DHW circulation is enabled (2).

## DL bus

The address is set with DIP switches on the PCB of the FRISTAR3 controller, which are labelled 1, 2 and 4. These are located on the outer edge of the PCB. If the DIP switches are not in the ON position, address 1 is assigned to the FRISTAR3 controller (factory setting). Provided no other sensors are connected to the DL bus, no change of address is required.

The new address is derived from address 1 (= factory setting) plus the sum of all values of the DIP switches that are set to ON.

**Example:** desired address 6 = 1 (from factory settings) + 1 + 4  
= DIP switches 1 and 4 must be set to ON

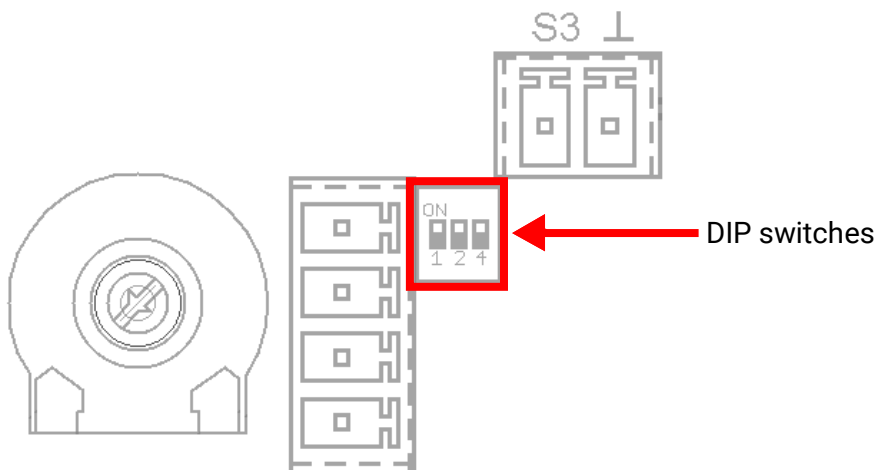

# Index

## DL inputs

A value can be read out from the FRISTAR3 controller via a DL input on the controller. The index of each value is fixed:

<b>Index:</b>	<b>Measurement:</b>
1	Actual DHW temperature $T_{ww}$ [°C]
2	Cold water temperature $T_{KW}$ [°C]
3	Flow rate [l/h]
4	Primary temperature $T_{Pri}$ [°C]
5	Circulation temperature [°C]
6	Set temperature [°C]
7	Pump output [%]
8	Valve position [%]
9	Current output [kW]
10	Total energy [kWh]
11	Total energy [MWh]
12	Water meter [m <sup>3</sup> ]
13	Status (see "Status" on page 17)

## DL outputs

A value can be given to the FRISTAR3 controller via a DL output on the controller. The index of each value is fixed:

<b>Index:</b>	<b>Measurement:</b>
1	Set temperature [°C]
2	Forced DHW circ. [On/Off]
3	Pause time DHW circ. [s]
4	Set temp. DHW circ. [°C]

## For UVR67

DL-Bus Address	<input type="text" value="1"/>
DL-Bus Index	<input type="text" value="2"/>

In the expert level under "Ext. sensors", DL bus is specified as the source for one of the inputs and the DL address of the FRISTAR3 controller is specified. The required index according to the table on the previous page should be entered underneath.

# Electrical connection

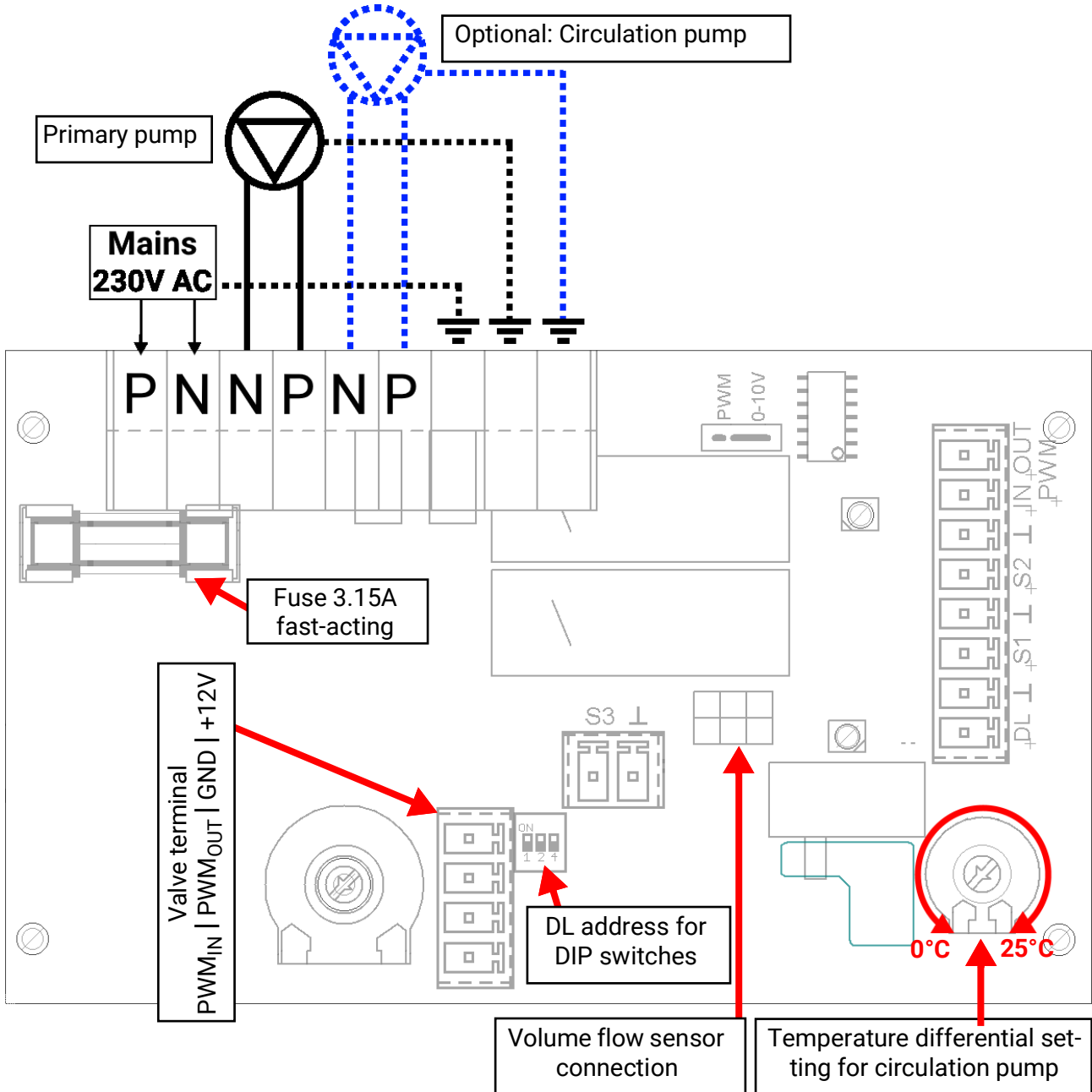

Terminal S1: Cold water temperature sensor  $T_{KW}$

Terminal S2: Primary temperature sensor  $T_{Pri}$

Terminal S3: Circulation temperature sensor  $T_{Zirku}$

The polarity of the DL bus connections (DL and "Earth") is **not** interchangeable and must be observed.

## Safety instructions

If you are connecting the FRISTAR3 to an electrical system via a residual current device (RCD), use an RCD of type A which will detect pulsating direct currents and bears the following marking:



Checking using a high voltage insulation tester may cause damage to the pump and the control electronics.

# Operation of the controller and LED indicators

Operation of the controller has been kept as simple as possible, so that it can also be operated by inexperienced users.

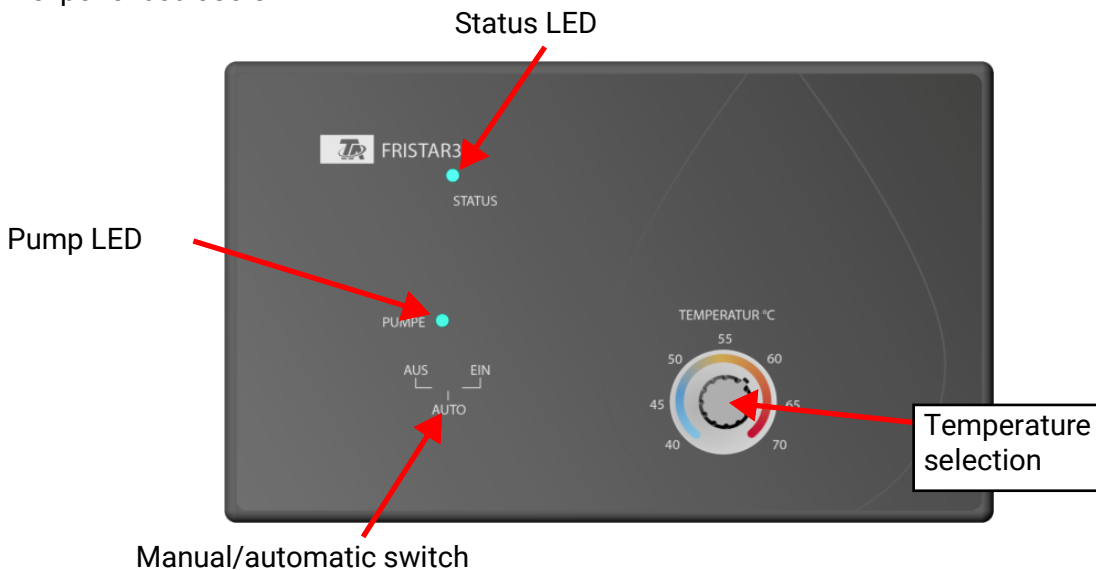

The temperature can only be selected on the FRISTAR3 controller if no set value has been issued by a freely programmable controller (e.g. UVR16x2) via the DL bus.

## Manual-automatic changeover switch

<b>AUS</b> (off)	The pump is permanently off and the valve is closed.
<b>AUTO</b>	Pump and valve operate as specified by the controller.
<b>EIN</b> (on)	The pump runs permanently at full speed and the valve is fully open, regardless of the control temperature.

## Emergency operation mode

In the Emergency operation mode, the pump and the valve are set to manual mode. This is controlled using the temperature dial on the front of the controller.

### Activation

If both temperature sensors S1 and S2 (see chapter "Electrical connection") are not connected when the FRISTAR3 starts (= power is supplied), the controller boots into Emergency operation mode. The LED will flash accordingly.

### Deactivation

Emergency operation mode can be deactivated by connecting both temperature sensors S1 and S2. A self-test will occur right after. If all required sensors, the pump and the valve function correctly, the Emergency operation mode ends and normal operation begins.

### Operation

When turning the temperature dial all the way to the left (= 40°C), the pump will not run and the valve will be shut (= 0%).

When turning the temperature dial all the way to the right (= 70°C), the pump will run with full speed and the valve will open all the way (= 100%).

The Manual-automatic changeover switch should be set to AUTO. The settings on and off cause pump and valve activity of 100% and 0% respectively. This overrides the setting of the dial.

## LED status displays

In the following, all possible status display of every LED is listed, in descending order of priority. Only topmost (= highest priority) active status will be displayed.

The LED will flash in the presented colours from left to right and then repeat the process of as long as the corresponding status (and no other status with higher priority) is active. Grey means that the LED is not lit.

One cell is equal to 250ms.

### LED „Status“

1. The controller is in **Emergency operation mode** (see page 20)



2. Valve **reset** active. If the controller receives feedback about an error from the valve, the valve will be reset. During this process, this LED status is active.



3. **Error:** Sensor for DHW temperature  $T_{WW}$  (in the flow sensor)



4. Primary pump **error**



5. Valve **error**



6. **Error:** cold water sensor  $T_{KW}$



7. **Error:** primary flow sensor  $T_{Pri}$



8. Controller, valve and all pumps are in working order.



### LED „Pump“

1. Circulation line pump is active



2. Primary pump is active



3. Pump is inactive. If the "Pump" LED is not lit despite DHW being drawn, the flow sensor or the controller is likely defective.



## Technical data

Rated power	70 kW
Min. flow	2 l/min
Max. flow for 65 °C tank and 45 °C outlet temperature	30 l/min
Max. permissible flow	30 l/min
Plate heat exchanger volumes, primary/secondary	1,28 l each
Max. operating pressure primary side (tank water)	4 bar
Max. operating pressure secondary side (cold water)	6 bar
Max. permissible water hammer pressure	15 bar
Rated temperatures primary flow / return	65 / 20 °C
Rated temperatures secondary flow / return	45 / 10 °C
Max. operating temperature primary/secondary	90 °C
Setting range for hot water temperature	40 - 70 °C
Pressure loss secondary side (Kv value)	2,60 m <sup>3</sup> /h
Connection thread primary, secondary. circulation pipe	G ¾" external thread
DL-Buslast	10%
Maximum electrical rating, pump + controller	80 W
<b>Materials</b> (all parts in contact with potable water comply with DVGW/W270)	
Fittings	Brass CW617N
Heat exchanger	Stainless steel 1.4401, copper soldered
Pipes	Copper 99,96%
Seal material	PTFE, EPDM, Klingsil C-4324
Pump primary circuit	Grundfos UPM3 15-70 130
Valve	ESBE SLB123
Volume flow sensor	Huba Type 200 2-32l/min
Primary sensor	PT1000
Controller	FWR33

### Transmission power with different flow and outlet temperatures:

Pump mode	Buffer flow [°C]	Return [°C]	Cold water supply [°C]	Hot water outlet [°C]	Power [kW]	Flow [l/h]
100%	59,3	25,0	10,3	45,0	68,7	1700
100%	55,4	27,0	10,3	45,0	56,5	1400
100%	50,3	33,2	10,3	45,4	34,7	850
100%	50,2	25,2	10,3	40,3	50,6	1450

## Pressure loss characteristic curve plate heat exchanger

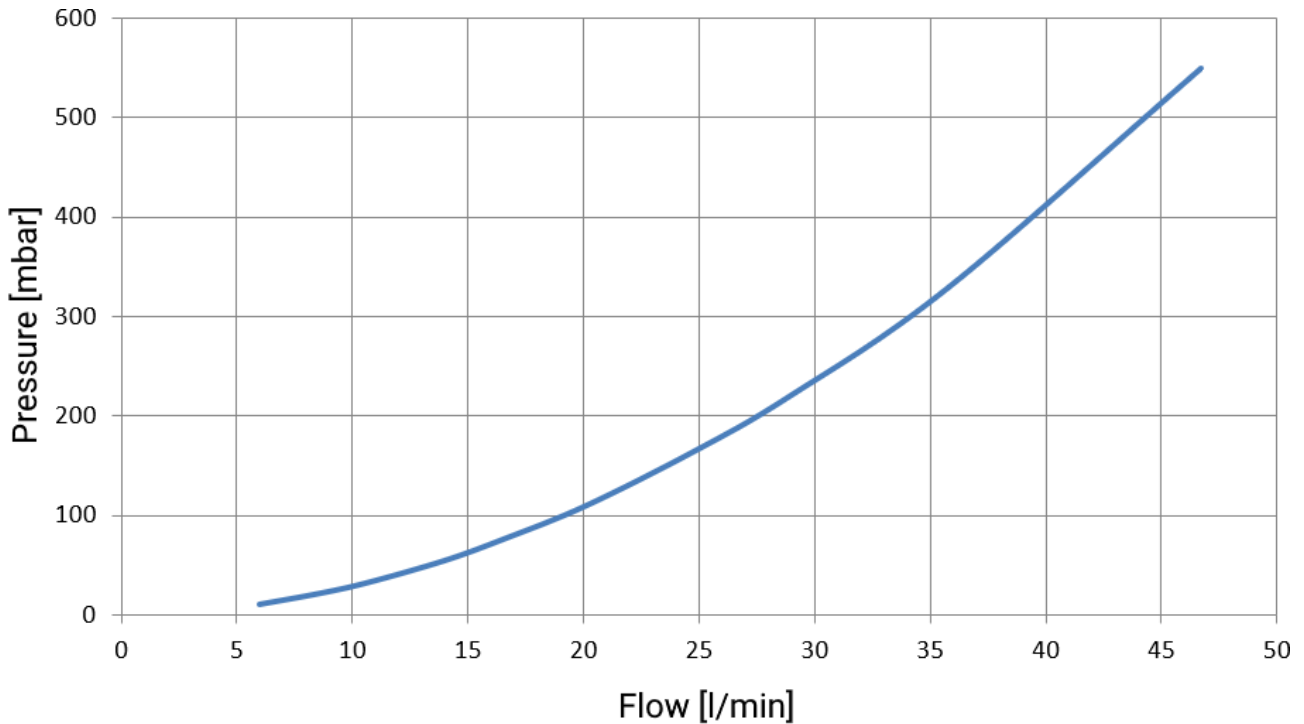

## Pump curve

(1 kPa = 10 mbar)

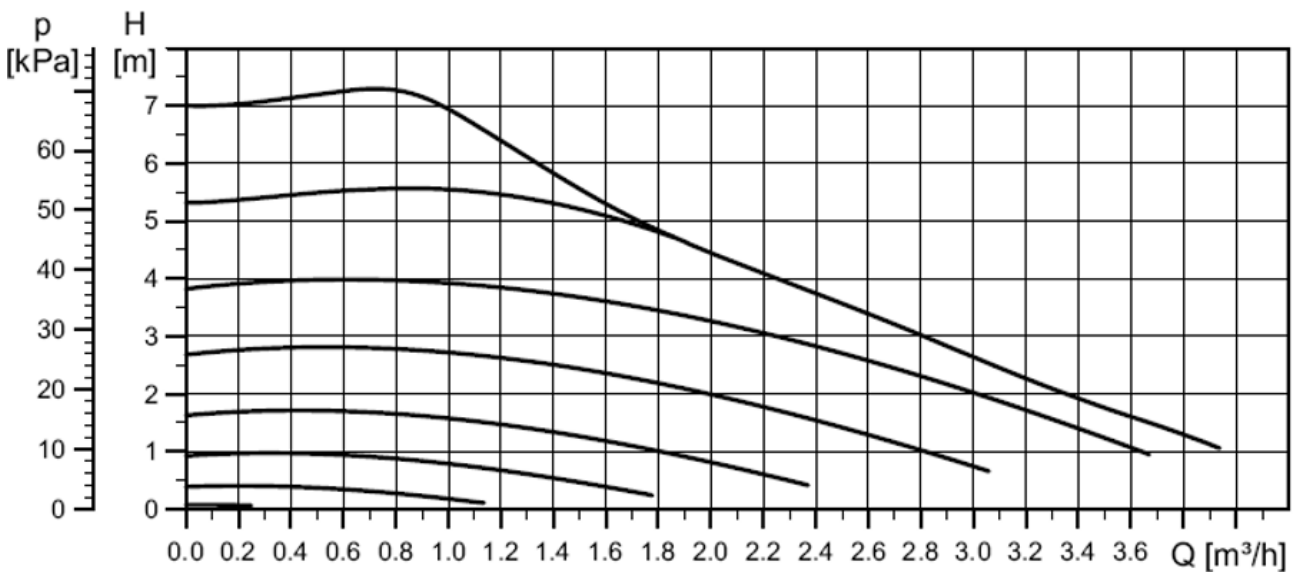

The pump operates in heating mode, meaning that at a 5 % PWM value, the pump will run at full speed. A break in the PWM lead therefore results in full pump speed.

The eight curves shown correspond to the following PWM values: 5 % (max.), 20 %, 31 %, 41 %, 52 %, 62 %, 73 %, 88 % (min.).

# Information on the Eco-design Directive 2009/125/EC

Product	Class <sup>1,2</sup>	Energy efficiency <sup>3</sup>	Standby max. [W]	Power consumption typ. [W] <sup>4</sup>	Max. power consumption [W] <sup>4</sup>
FWR33	1	1	1,0	0,88 / 0,90	1,0 / 3,0

<sup>1</sup> Definitions according to Official Journal of the European Union C 207 dated 03/07/2014

<sup>2</sup> The classification applied is based on optimum utilisation and correct application of the products. The actual applicable class may differ from the classification applied.

<sup>3</sup> Contribution of the temperature controller to seasonal central heating efficiency in percent, rounded to one decimal place

<sup>4</sup> No output active = standby / all outputs active

## Plate heat exchanger corrosion resistance

Water containing material		Water containing material	
Chloride	See diagram	Saturation index SI	-0,2 < 0 < +0,2
Iron	< 0,2 mg/l	Total hardness	6 - 15 °dH
Manganese	< 0,1 mg/l	Filterable substances	< 30 mg/l
Ammonia	< 2 mg/l	Free chlorine	< 0,5 mg/l
pH value	7 - 9	Hydrogen sulphide	<0,05 mg/l
Electrical conductivity	10 - 500 µS/cm	Hydrogen carbonate/ sulphate	> 1 mg/l
Free carbonic acid	< 20 mg/l	Hydrogen carbonate	< 300 mg/l
Nitrate	< 100 mg/l	Sulphide	< 1 mg/l
Sulphate	< 100 mg/l	Nitrite	< 0,1 mg/l

The corrosion behaviour of stainless steel and copper solder must be considered.

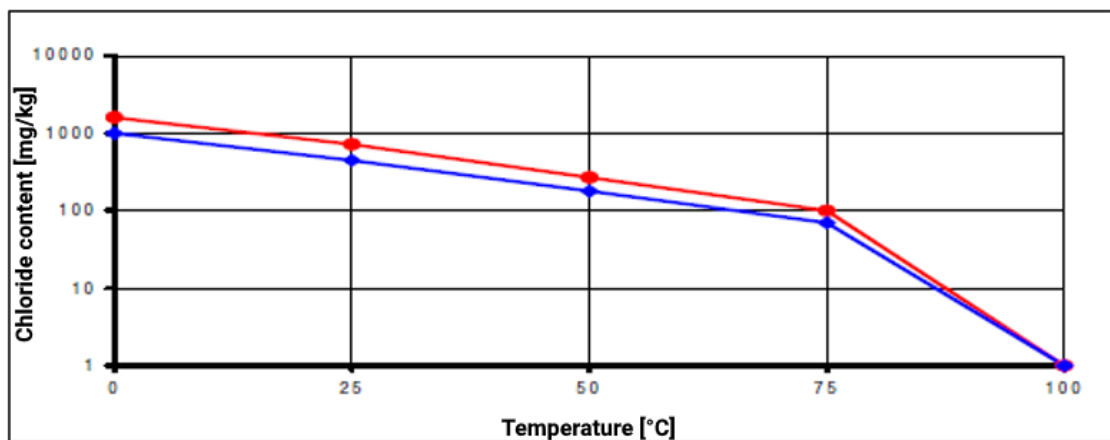



# Tips on troubleshooting

The following troubleshooting approaches may help in the event of faulty operation, but before working on the freshwater module, it is always important to ensure that it is at zero volt and that no hot pipe temperatures can occur.

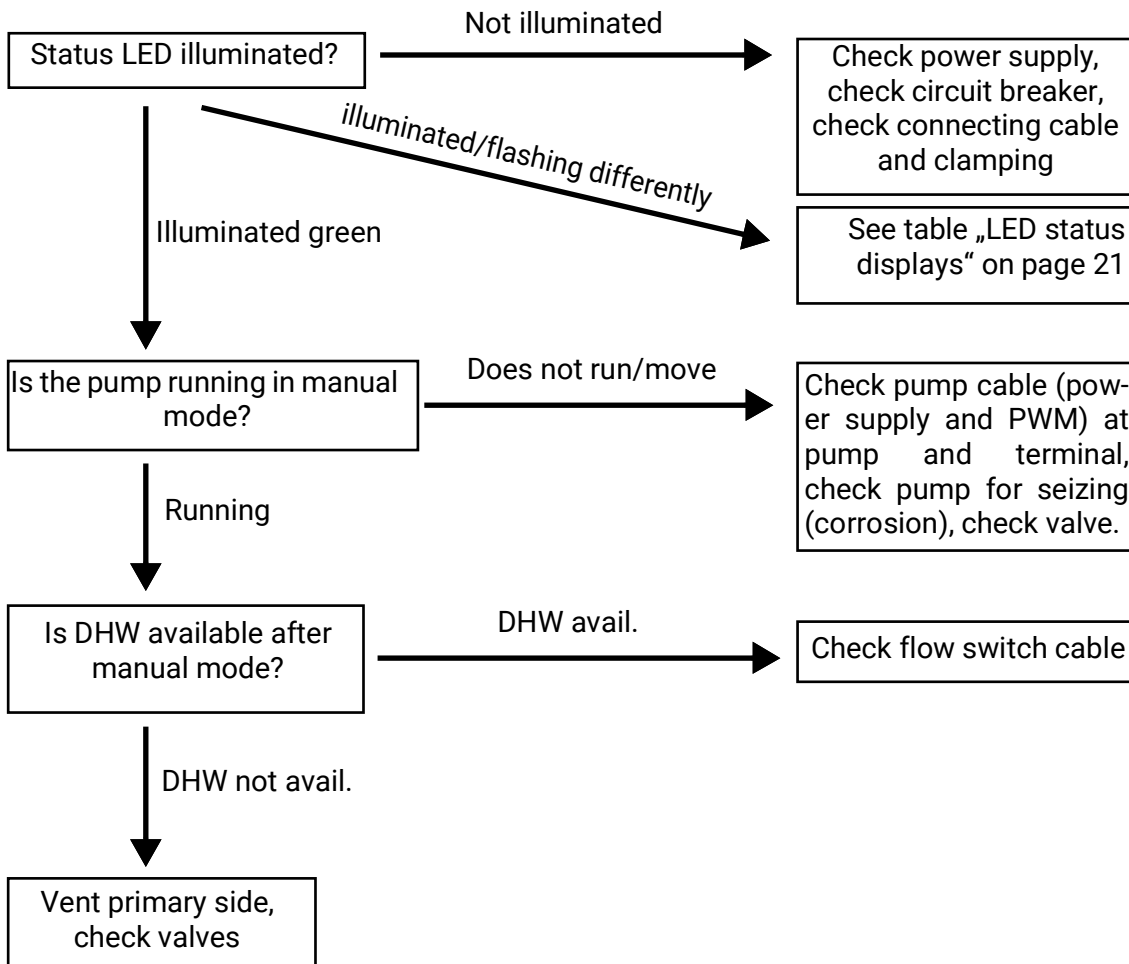

Other possible solutions:

- Check temperature sensors (sensors and wiring)
- Check cable connection between controller and flow sensor
- Check water pressure on secondary side
- Check flow sensor for contamination
- Check position of set value adjuster (may be twisted by 180°)

Subject to technical modifications as well as typographical and printing errors. This manual is only valid for devices with the corresponding firmware version. Our products are subject to constant technical advancement and further development. We therefore reserve the right to make changes without prior notice.

© 2023

# EU Declaration of conformity

Document-No. / Date: TA21001 / 19/02/2021  
Company / Manufacturer: Technische Alternative RT GmbH  
Address: A-3872 Amaliendorf, Langestraße 124

**This declaration of conformity is issued under the sole responsibility of the manufacturer.**

Product name: FRISTAR3 / FRISTAR3-WP  
Product brand: Technische Alternative RT GmbH  
Product description: Fresh water station

**The object of the declaration described above is in conformity with Directives:**

2014/35/EU Low voltage standard  
2014/30/EU (11/09/2018) Electromagnetic compatibility  
2011/65/EU (01/10/2022) RoHS Restriction of the use of certain hazardous substances  
2009/125/EU (04/12/2012) Eco-design directive

**Employed standards:**

EN 60730-1: 2011	Automatic electrical controls for household and similar use – Part 1: General requirements
EN 61000-6-3: 2007 + A1: 2011 + AC2012	Electromagnetic compatibility (EMC) - Part 6-3: Generic standards - Emission standard for residential, commercial and light-industrial environments
EN 61000-6-2: 2005 + AC2005	Electromagnetic compatibility (EMC) - Part 6-2: Generic standards - Immunity for industrial environments
EN 50581: 2012	Technical documentation for the assessment of electrical and electronic products with respect to the restriction of hazardous substances

**For Grundfos pump:** EN 60335-1:2012/AC:2014, EN 60335-2-51:2003/A1:2008/A2:2012, EN 55014- 1:2006/A1:2009, EN 55014-2:1997/A1:2001/A2:2008, EN 16297-1:2012, EN 16297-2:2012, EN 16297- 3:2012

**Position of CE - label:** On packaging, manual and type label



Issuer: Technische Alternative RT GmbH  
A-3872 Amaliendorf, Langestraße 124

**This declaration is submitted by**

A handwritten signature in black ink, appearing to read 'Schneider Andreas', is written over a light blue horizontal line.

Dipl.-Ing. Andreas Schneider, General manager,  
19/02/2021

This declaration certifies the agreement with the named standards, contains however no warranty of characteristics.

The security advices of included product documents are to be considered.



## Warranty conditions

**Note:** The following warranty conditions do not in any way limit the legal right to warranty, but rather expand your rights as a consumer.

1. The company Technische Alternative RT GmbH provides a one-year warranty from the date of purchase for all the devices and parts which it sells. Defects must be reported immediately upon detection and within the guarantee period. Technical support knows the correct solution for nearly all problems. In this respect, contacting us immediately will help to avoid unnecessary expense or effort in troubleshooting.
2. The warranty includes the free of charge repair (but not the cost of on site troubleshooting, removal, refitting and shipping) of operational and material defects which impair operation. In the event that a repair is not, for reasons of cost, worthwhile according to the assessment of the Technische Alternative company, the goods will be replaced.
3. Not included is damage resulting from the effects of over-voltage or abnormal ambient conditions. Likewise, no warranty liability can be accepted if the device defect is due to: transport damage for which we are not responsible, incorrect installation and assembly, incorrect use, disregard of operating and installation instructions or incorrect maintenance.
4. The warranty claim will expire, if repairs or actions are carried out by persons who are not authorised to do so or have not been so authorised by us or if our devices are operated with spare, supplementary or accessory parts which are not considered to be original parts.
5. The defective parts must be sent to our factory with an enclosed copy of the proof of purchase and a precise description of the defect. Processing is accelerated if an RMA number is applied for via our home page [www.ta.co.at](http://www.ta.co.at). A prior clarification of the defect with our technical support is necessary.
6. Services provided under warranty result neither in an extension of the warranty period nor in a resetting of the warranty period. The warranty period for fitted parts ends with the warranty period of the whole device.
7. Extended or other claims, especially those for compensation for damage other than to the device itself are, insofar as a liability is not legally required, excluded.

### Legal notice

These assembly and operating instructions are protected by copyright.

Use outside the copyright requires the consent of the company Technische Alternative RT GmbH.

This applies in particular to reproductions, translations and electronic media.

## Technische Alternative RT GmbH

A-3872 Amaliendorf, Langestraße 124

Tel.: +43 (0)2862 53635

E-Mail: [mail@ta.co.at](mailto:mail@ta.co.at)

Fax +43 (0)2862 53635 7

-- [www.ta.co.at](http://www.ta.co.at) --



©2023