



UVR610K-OD

FREELY PROGRAMMABLE
UNIVERSAL CONTROLLER

Console without display



Installation instructions

Table of contents

Manual Version 1.41

Safety requirements	3
Maintenance	3
Disposal	3
Standard delivery	4
SD card	4
Installing the device	4
Opening the module	4
Mounting dimensions	4
Sensor installation	5
Electrical connection	6
Terminal diagram	7
Jumper setting J1 and J2	7
Mains connection	7
Sensor leads	8
Sensor terminal diagram	8
Data cable for DL bus	9
Terminal diagram, DL bus data cable	9
Bus load of DL sensors	9
CORA devices	9
CAN Bus network	10
Terminal diagram, CAN bus cable	10
Guidelines for the topology of a CAN network	10
Technical principles	10
Lightning protection	11
Examples of different network versions	11
Cable selection and network topology	13
Outputs	16
Terminal diagram, switching outputs	16
Terminal diagram for analogue outputs (0-10V / PWM)	17
24V supply	17
M-Bus	17
Connection auxiliary relay HIREL-230V	18
HIREL-230V wiring diagram	18
Technical data UVR610K-OD	19
Tips on troubleshooting	20
Tech-support	20
Troubleshooting in the CAN network	22
Information on the ECO-design Directive 2009/125/EG	22

Safety requirements



All installation and wiring work on the controller must only be carried out in a zero volt state. The opening, connection and commissioning of the device may only be carried out by competent personnel. While doing so, they must observe all local safety requirements.

This device is state of the art and meets all necessary safety regulations. It may only be used in accordance with the technical data and the safety requirements and regulations listed below. When using the device, also observe the statutory and safety regulations apposite to the particular use. Any other use will automatically void all warranty rights.

- The device must only be installed in a **dry** interior room.
- It must be possible to isolate the controller from the mains using an omnipolar isolating facility (plug/socket or 2-pole isolator).
- Before starting installation or wiring work, the controller must be completely isolated from the mains and protected against reconnection. Never interchange the safety low voltage connections (e.g. sensor connections) with the 230 V connections. Destruction and life threatening voltages at the device and the connected sensors may occur.
- Solar thermal systems can become very hot. Consequently there is a risk of burns. Proceed with caution when fitting temperature sensors.
- For safety reasons, the outputs should only be left in manual mode when testing. In this operating mode, no maximum temperatures or sensor functions are monitored.
- Safe operation is no longer possible if the controller or connected equipment exhibits visual damage, no longer functions or has been stored for lengthy periods in unsuitable conditions. If this is the case, disable the controller and equipment and secure against unintentional use.

Maintenance

If treated and used correctly, the device will not require any maintenance. Use a cloth moistened with mild alcohol (such as methylated spirits) to clean. Never use corrosive cleaning agents or solvents such as chloroethylene or trichloroethylene.

No components relevant to long term accuracy are subject to loading if the device is used correctly. Consequently long term drift is extremely low. The device therefore cannot be calibrated. Thus applying any compensation is impossible.

The design characteristics of the device must not be changed during repairs. Spare parts must correspond to the original spare parts and must be used in accordance with the build version.

Disposal

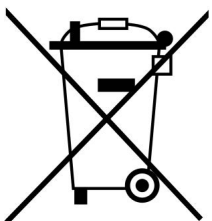

- Devices no longer in use or beyond a state of repair must be disposed of in an environmentally responsible manner by an authorised collection point. They must never be treated as ordinary household waste.
- We can undertake the environmentally responsible disposal of devices sold by the Technischen Alternative company upon request.
- Packaging material must be disposed of in an environmentally responsible manner.
- Incorrect disposal may result in considerable damage to the environment, as many of the materials used require professional handling.

Standard delivery

- Freely programmable universal controller UVR610K-OD
- Installation instructions
- Installation material
 - 1x 4-pole terminal, contact spacing: 3.81 mm
 - 1x 8-pole terminal, contact spacing: 3.81 mm
 - 1x 11-pole terminal, contact spacing: 3.81 mm
 - 3x 6-pole terminal, contact spacing: 5.08 mm

SD card

The UVR610K-OD does not have an SD card slot.

Installing the device

Opening the module

The device may only be opened at the manufacturer's premises, otherwise the enclosure will be damaged. It is not necessary to open the enclosure to use the full range of functions.

Mounting dimensions

The lower section can be mounted on a top-hat rail (TS35 support rail to EN 50022 standard).

The UVR610K-OD has a width of 6 DU (division units) as per DIN 43880.

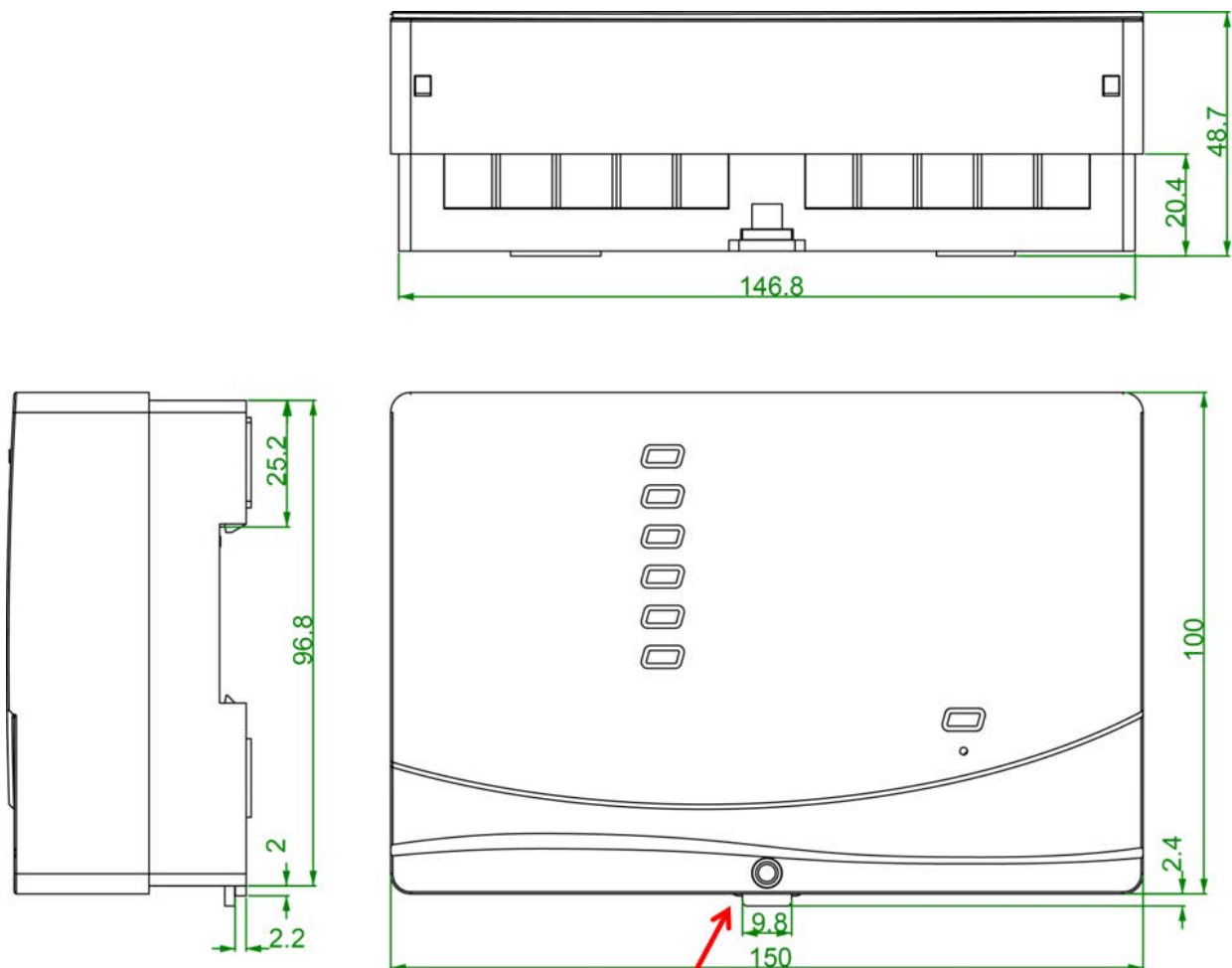

**Release for top-hat rail
mounting (TS35 support rail)**

Sensor installation

Correct arrangement and installation of the sensors is extremely important for correct functioning of the system. To this end, also ensure that they are completely inserted in their sensor wells. The cable fittings provided serve as strain relief. When used outdoors, no water must be allowed to penetrate the sensor wells (**risk of frost**). The contact sensors must be insulated well to protect them from being influenced by the ambient temperature.

Sensors should generally not be exposed to moisture (such as condensation) since this can diffuse through the cast resin and damage the sensor. If this happens, heating the sensor to 90 °C for an hour may help. When using sensor wells in stainless steel cylinders or swimming pools, particular attention must be given to their corrosion resistance.

- **Collector sensor (grey lead with junction box):** Either insert into a pipe which is brazed or riveted directly to the absorber and protrudes from the collector housing, or insert a tee into the flow manifold of the outermost collector into which the sensor well, together with the brass cable fitting (= protection against moisture), can be inserted; then insert the sensor. To protect against lightning damage, the junction box has a surge protection (voltage dependent resistor) which is clamped in parallel between the sensor and the extension cable.
- **Boiler sensor (boiler flow):** This sensor is either inserted into a sensor well in the boiler or fitted to the flow line as close to the boiler as possible.
- **DHW cylinder sensor:** The sensor required for the solar thermal system should be used with a sensor well for finned tube heat exchangers just above the exchanger or, if integrated smooth tube heat exchangers are used, in the lower third of the exchanger or the exchanger's return outlet so that the sensor well protrudes into the heat exchanger tube. The sensor monitoring the heating of the DHW cylinder by the boiler is installed at a level corresponding to the amount of domestic hot water required during the heating season. The supplied cable fitting acts as strain relief. Installation below the associated coil or heat exchanger is not permissible under any circumstances.
- **Buffer sensor:** The sensor required for the solar thermal system is fitted in the lower section of the cylinder just above the solar indirect coil using the sensor well supplied. The supplied cable fitting acts as strain relief. As the reference sensor for the heating system hydraulics, it is recommended to insert the sensor into the sensor well between the centre and upper third of the buffer cylinder, or positioned against the cylinder wall underneath the insulation.
- **Pool sensor (swimming pool):** Fit a tee into the suction line immediately on the pool outlet and insert the sensor with a sensor well. In the process, ensure the material used is corrosion-resistant. A further option would be to fit the sensor as a contact sensor with appropriate thermal insulation against ambient influences.
- **Contact sensor:** Use scroll springs, pipe clips, etc. to attach the contact sensor to the respective line. Ensure the material used is suitable (corrosion, temperature resistance, etc.). Then insulate the sensor thoroughly so that the pipe temperature is captured accurately and ambient temperatures cannot falsify the result.
- **DHW sensor:** A rapid reaction to changes in the water volume is extremely important when using the controller in systems that generate domestic hot water by means of an external heat exchanger and variable speed pump (freshwater module). Therefore fit the DHW sensor directly on the heat exchanger outlet. This ultra-quick sensor (special accessory, type MSP) should protrude into the output with the aid of a tee sealed in with an O-ring. The heat exchanger should be installed upright with the DHW outlet at the top
- **Radiation sensor:** The parallel collector orientation is important in order to obtain a measurement that corresponds to the collector position. Consequently it should be secured to the sheet steel covering or adjacent to the collector on an extension of the mounting rail. To this end, the sensor casing has a blind hole that can be opened at any time. The sensor is also available as a wireless version.

- **Room sensor:** This sensor is intended for installation in the living space (reference room). Do not install the room sensor near a heat source or window. By simply replugging a jumper inside the sensor, each room sensor can also be used exclusively as a remote adjuster (no room temperature influence). It is only suitable for operation in dry rooms. The sensor is also available as a wireless version.
- **Outside temperature sensor:** This sensor is installed on the coldest wall (usually facing north) some two meters above the ground. Avoid temperature influences from nearby air shafts, open windows, cable ways, etc. It must not be subjected to direct insolation.

Electrical connection

This must only be carried out by a qualified electrician in accordance with the relevant local regulations.

Note: In line with regulations, the system must be equipped with protection against lightning (surge arrester). Sensor failures due to thunderstorms and static electricity are usually the result of missing or incorrect earthing or missing surge protection.

Caution: Only work inside the module when the power supply is at zero volt. Assembling the device with the power connected may result in damage.

Connect all sensors and pumps/valves as they are numbered in the respective program.

In the mains voltage range, fine wire cross-sections of 0.75 - 1.5 mm² are recommended, except for the supply cable.

A terminal strip is provided in the 230 V terminal box for connection of the earth conductor (PE). All cables can be fixed with a locking clamp (= strain relief) immediately after termination. Subsequently, side cutters are required to remove the locking clamps; therefore, more clamps than necessary are provided.

Terminal diagram

View of the upper enclosure section with terminals

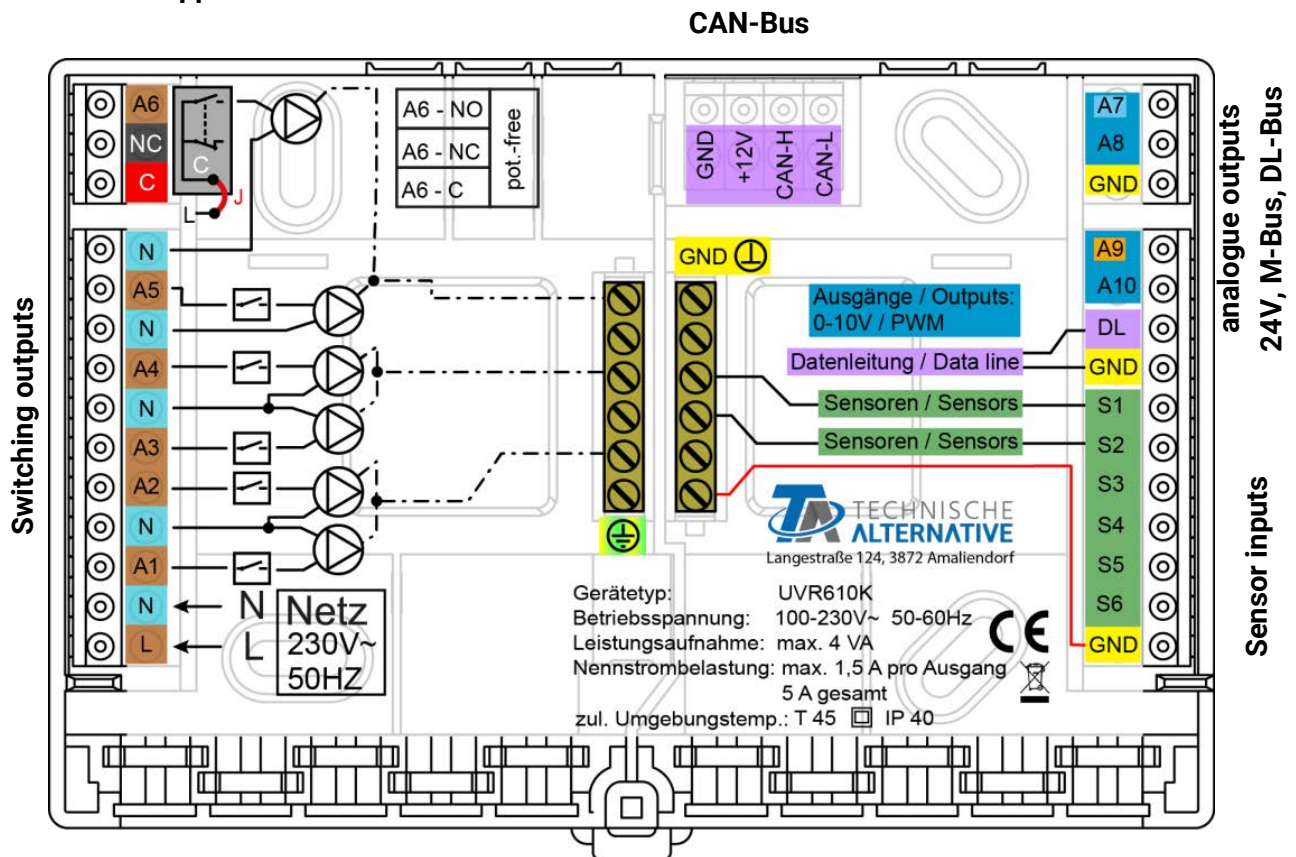

Mains:	
L...	Phase conductor
N...	Neutral conductor
Outputs:	
C...	Root
A1 - A6...	NO contact
NC...	N/C contact A6
N...	Neutral conductor
L1...	Phase conductor output

Jumper setting J1 and J2

The jumpers of the UVR610K(-OD) are located in the cover electronics (see page 17 for graphic).

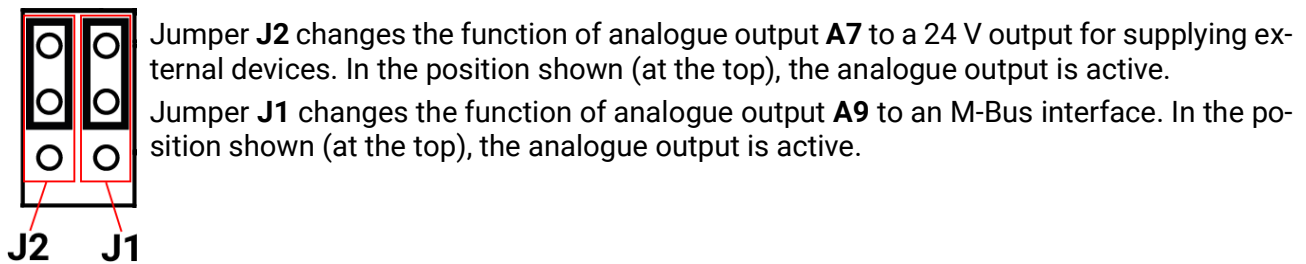

Mains connection

Power is supplied through a power supply unit integrated into the module. The mains connection must therefore be **230 V 50 Hz**. This is also the voltage conducted by the output relay. The integral power supply unit also supplies power to the CAN bus.

Sensor leads

Sensor terminal diagram

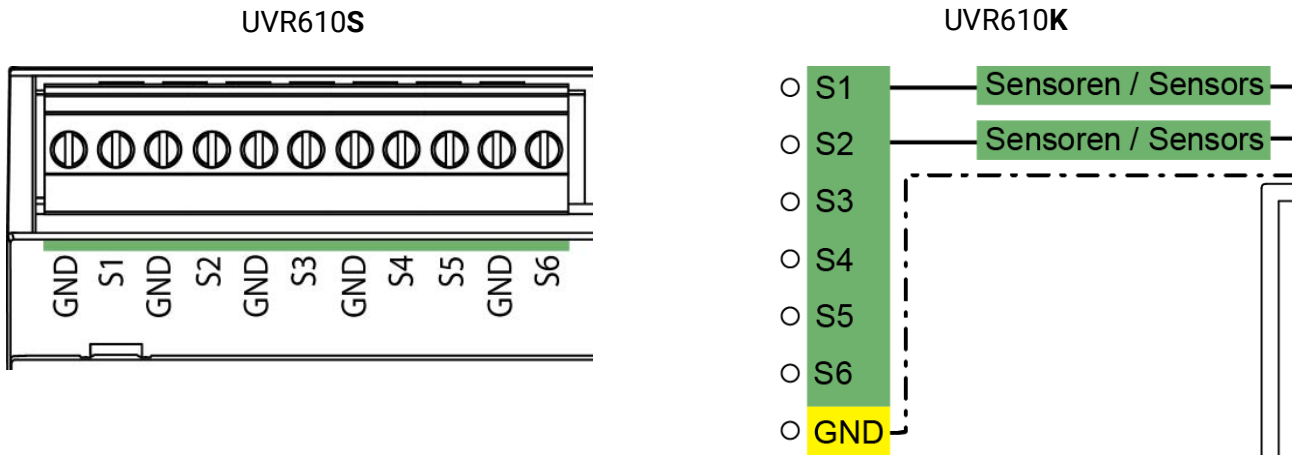

Sensors are always connected across the relevant sensor terminal (**S1 – S6**) and sensor earth (**GND**).

In order to prevent measurement fluctuations and ensure perfect signal transmission, sensor leads must not be subject to external negative influences through 230 V cables.

Never run sensor leads together with mains voltage cables in the same conduit.

When using non-screened cables, route sensor leads and 230 V cables either in separate cable conduits or with a minimum clearance of 5 cm.

Sensor leads for PT100 or PT500 sensors must be screened.

If screened cables are used, the screen must be connected to the sensor earth (**GND**)

All sensor leads with a cross-section of 0.5 mm² can be extended to up to 50 metres. With this lead length and a PT1000 temperature sensor, the measuring error is approximately +1 K. A correspondingly larger cross-section is required for longer leads or a lesser measuring error.

The connection between the sensor and the extension can be made by pushing heat shrink tubing (trimmed to 4 cm) over one core and twisting the bare wire ends. Solder the connection if one of the wire ends has been tin-plated.

Then push the heat shrink tubing over the connection and heat up carefully (e.g. with a lighter) until it sits tightly over the connection.

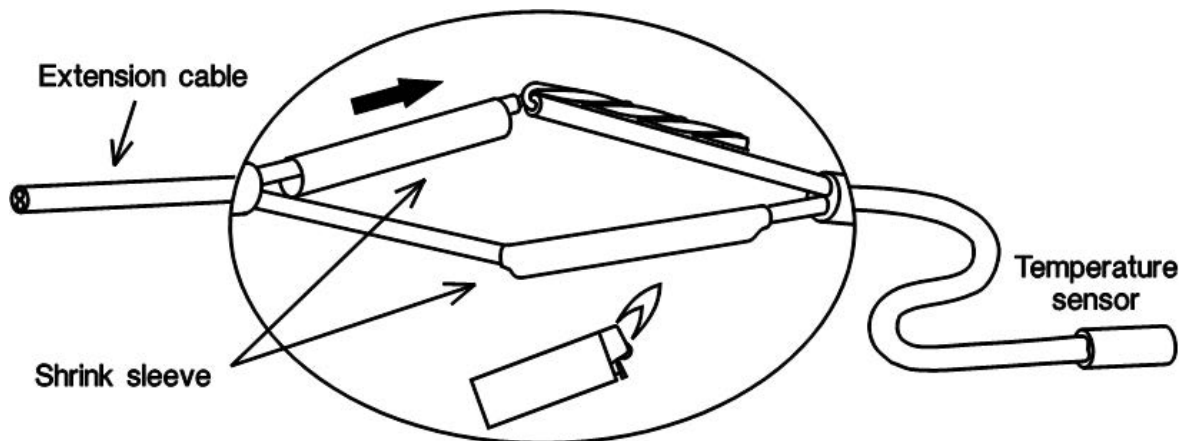

Data cable for DL bus

The DL BUS consists of just 2 wires: DL and GND (sensor earth). The DL BUS itself supplies the necessary power for the DL BUS sensors.

Cables can be routed with a star topology but also in serial formation (from one device to the next). Any cable with a cross-section of 0.75 mm², and measuring up to 30 m in length, can be used as a data link. For lengths greater than 30 m, the use of screened cables is recommended, which increases the reliable length of the cable to 100 m.

If screened cables are used, the screen must be connected to GND.

Long cable conduits routed closely next to each other for mains and data cables result in faults being induced into the data cables from the mains. We therefore recommend a minimum clearance of 20 cm between two cable conduits or the use of screened cables.

Use separate, screened cables when capturing data from two controllers with a single datalogger. Never run the data cable together with a CAN BUS cable in the same conduit.

Terminal diagram, DL bus data cable

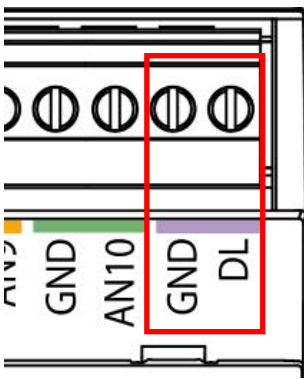

Bus load of DL sensors

A 2-pole cable provides **both** the power supply and the signal transfer from DL BUS sensors. An additional power supply by means of an external power supply unit (such as with the CAN BUS) is not possible.

Take the "**Bus load**" into consideration as sensors have a relatively high current demand:

The UVR610 supplies a **total** bus load of 100%. The bus loads of the electronic sensors are listed in the technical data of the relevant sensors.

Example: The electronic sensor FTS4-50DL has a bus load of 25%. Consequently up to four FTS4-50DL can be connected to the DL bus.

CORA devices

CORA devices can be connected to the UVR610 controller by cable (software version 1.09 or higher).

They are connected at the controller's DL bus. CORA devices connected in this way have no effect on the DL bus load or other DL devices. If using CORA-DL, ensure correct polarity.

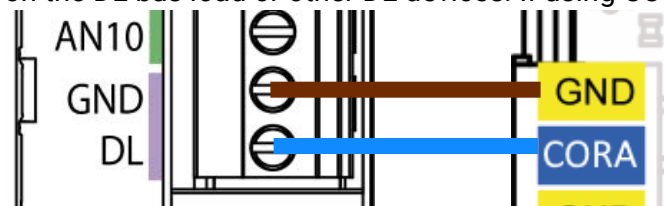

CAN Bus network

Terminal diagram, CAN bus cable

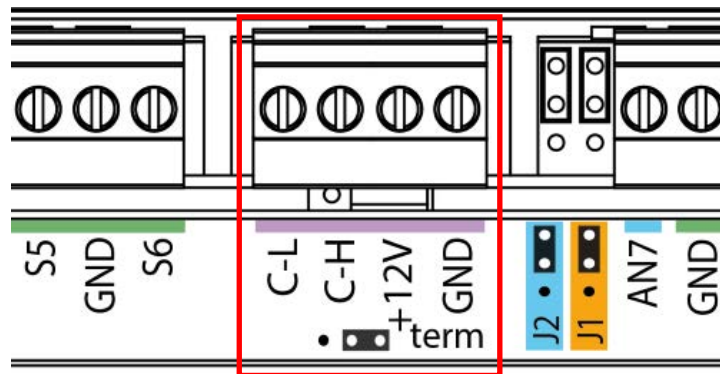

Guidelines for the topology of a CAN network

Technical principles

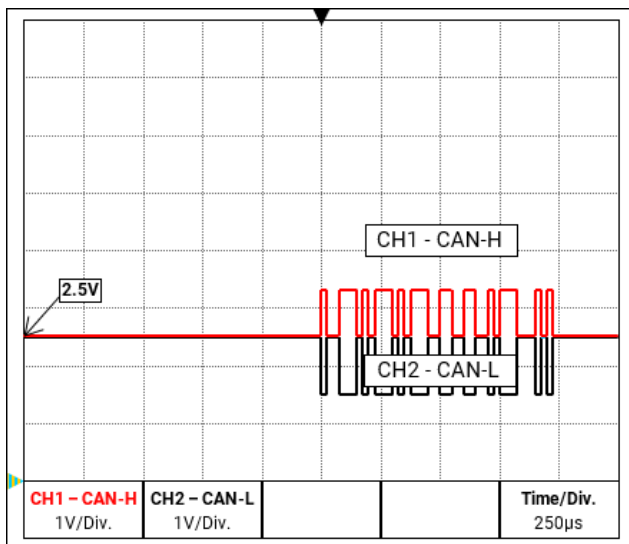

CAN-H and CAN-L data signals

The CAN BUS comprises the cables CAN-High, CAN-Low, GND and one +12 V supply cable for BUS components without their own power supply. The combined total load of all devices with 12 V and 24 V supply must not exceed 6 W.

Design CAN networks in a linear fashion and set a terminator at each network termination. This is ensured by the termination of the end devices. In the case of larger networks (covering several buildings), problems can occur through electromagnetic interference and potential differences.

To avoid or to the greatest extent manage such problems, take the following measures:

- Cable screening**
 The BUS cable screen must be connected well at every node to provide continuity. For larger networks we recommend including the screen in the equipotential bonding, in line with the examples shown.
- Equipotential bonding**
 As low an ohm connection as possible to the earth potential is particularly important. Where cables enter buildings, ensure that the cable entries are in the same location where possible and that all are connected to the same equipotential bonding system ($S_{\text{ingle}}E_{\text{entry}}P_{\text{oint}}$ principle). The purpose is to create potentials that are as similar as possible, in order to achieve the smallest possible potential difference to adjacent lines in case one line suffers a voltage surge (lightning strike). Also ensure a corresponding clearance between the cable and lightning protection systems.
 The equipotential bonding also has positive properties to counteract interferences emitted from linked cables.

- **Avoiding earth loops**

Where a bus cable is routed between several buildings, ensure that earth loops are avoided. The reason for this is that buildings actually have different potentials compared to the earth potential. An earth loop is created when connecting one cable screen in each building **directly** with the equipotential bonding system. In other words, a current flows from the higher to the lower potential.

For example, if lightning strikes near one of the buildings, the potential of that building will briefly be raised by several kV.

In this case, the equalizing current flows to earth via the bus screen and causes an extreme electromagnetic input which can result in the destruction of the bus components.

Lightning protection

Efficient lightning protection is highly dependent on good building earthing that meets the relevant regulations.

An external lightning protection system offers protection against a **direct** lightning strike.

In order to protect against voltage surges in the 230 V mains supply cable (**indirect** lightning strike), appropriate lightning conductors and surge arresters compliant with local regulations must be fitted in the upstream distribution systems.

In order to protect the individual components of a CAN network against **indirect** lightning strike, we recommend the use of surge arresters specifically developed for bus systems.

Example: CAN bus surge arresters CAN-UES from Technische Alternative
Gas discharge arrester for indirect earthing EPCOS N81-A90X

Examples of different network versions

Key to symbols:

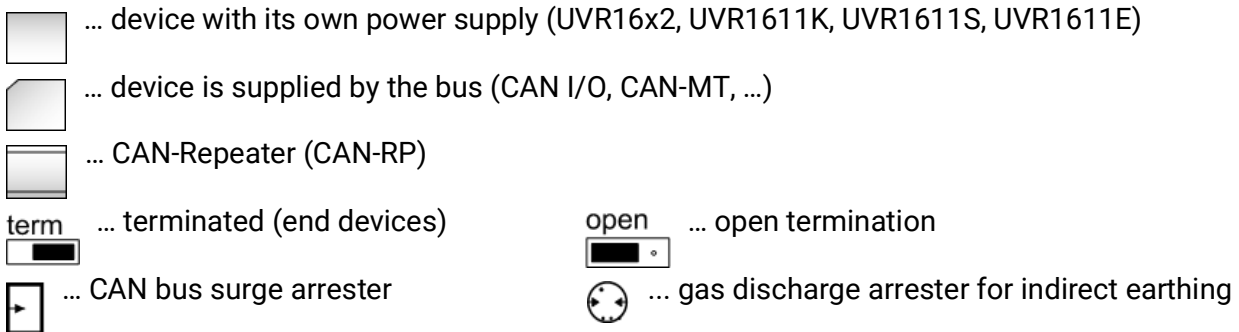

„Small“ network (within one building):

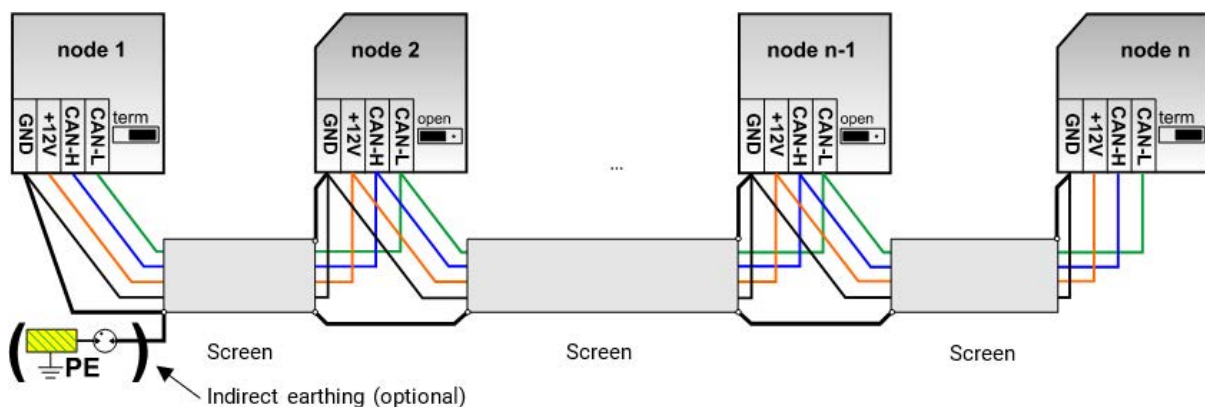

Max. cable length: 1000 m at 50 kbit/s

The screen must be continued at each network node and be connected to the device earth (GND). The screen earthing or GND must only be implemented **indirectly** via a gas discharge arrester.

Ensure that no unintentional **direct** connection of earth or screen and the earth potential is created (e.g. via sensors and the earthed pipework).

Network (across several buildings) without CAN-Repeater CAN-RP:

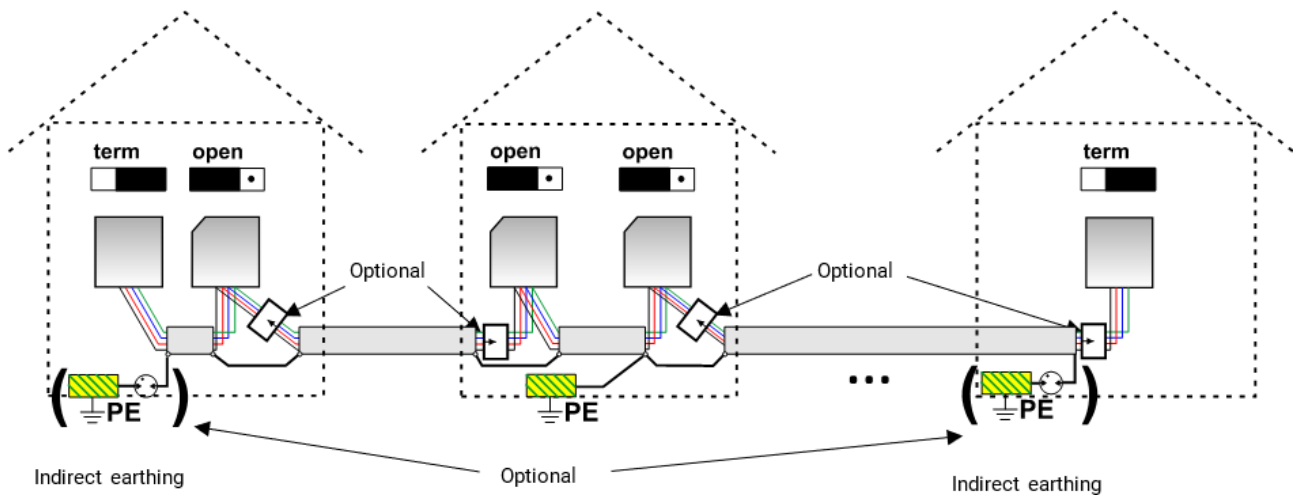

Max. cable length: 1000 m at 50 kbit/s

The screen must be continued at every network node and earthed at a **single** point, as close to the cable center as possible. We recommend earthing the screen **indirectly** in the other buildings using a gas discharge arrester. The screen is **not** connected with the earth (GND) of the devices.

Netzwerk (across several buildings) with CAN-Repeater CAN-RP:

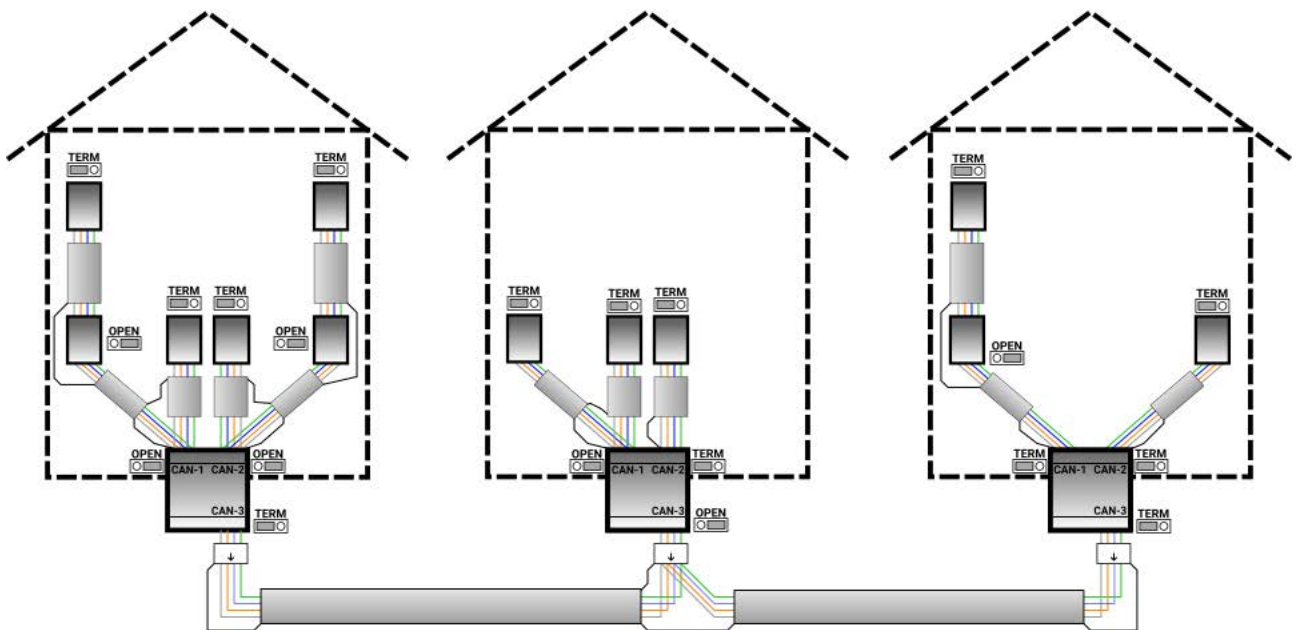

Maximum cable length: subject to the set Baud rate

The screen of the **disconnected** network is connected at each bus converter to CAN bus earth (GND). This screen must **not** be **directly** earthed.

Without CAN Bus surge arresters, this version only protects against potential differences **up to 1 kV**, therefore cannot be considered as lightning protection. In this case, the cable screen must be earthed at a **single** point between the CAN bus converters, as close to the cable centre as possible. We recommend earthing the screen **indirectly** in the other buildings using a gas discharge arrester.

A CAN bus converter is similar to a repeater. It receives CAN bus signals and passes them on. Each cable run on either side of the CAN bus converter must therefore be viewed as an independent CAN bus network.

Cable selection and network topology

Screened **twisted pairs** have proven useful in CANopen networks. These are cables with twisted pairs of conductors and a shared external screen. Such cables are relatively resistant to EMC interference and can still carry 50 kbit/s for up to 1000 m. The CANopen recommendations (CiA DR 303-1) for cable cross-sections are given in the table below.

Bus length [m]	Resistance in terms of length [mΩ/m]	Cross-section [mm ²]
0...40	70	0,25...0,34
40...300	< 60	0,34...0,60
300...600	< 40	0,50...0,60
600...1000	< 26	0,75...0,80

The maximum cable length also depends on the number of nodes [n] linked with the bus cable and the cable cross-section [mm²].

Cable cross-section [mm ²]	Maximum length [m]	
	n=32	n=63
0,25	200	170
0,50	360	310
0,75	550	470

Bus rate

In the CAN bus / CAN settings menu of the UVR16x2, the bus rate can be set to between 5 and 500 kbit/s, whereby lower bus rates enable longer cable networks. However, in this case, the cable cross-section must be increased accordingly.

The standard bus rate of the CAN network is 50 kbit/s (50 kBaud), which is specified for many CAN bus devices.

Important: All devices in the CAN bus network must have the **same** transfer rate in order to be able to communicate with each other. If even just one single device has a different transfer rate to all the others, then no communication at all is possible.

Bus rate [kbit/s]	Maximum permissible total bus length [m]
5	10.000
10	5.000
20	2.500
50 (standard)	1.000
125	400
250	200
500	100

Recommendations

A 2x2-pole, screened twisted pair (twist CAN-L with CAN-H or +12 V with GND) with a cable cross-section of at least 0.5 mm² and a conductor-to-conductor capacity of no more than 60 pF/m and a nominal impedance of 120 ohms. The standard bus speed of the UVR16x2 is 50 kbit/s. This recommendation corresponds, for example, to cable type **Unitronic®-BUS CAN 2x2x0.5** supplied by **Lapp Kabel** for permanent installation **in buildings or conduits**. Theoretically this would enable a bus length of approx. 500 m to guarantee reliable transmission.

For **direct routing underground**, earth cable **2x2x0.5** mm² supplied by **HELUKABEL**, part no. 804269, or earth cable **2x2x0.75** mm² supplied by **Faber Kabel**, part no. 101465, would be suitable.

Wiring

A CAN BUS network should never have a **star topology**. Rather, the correct topology is a line from the first device (with terminator) to the second, third and so forth. The last bus device has the termination jumper again.

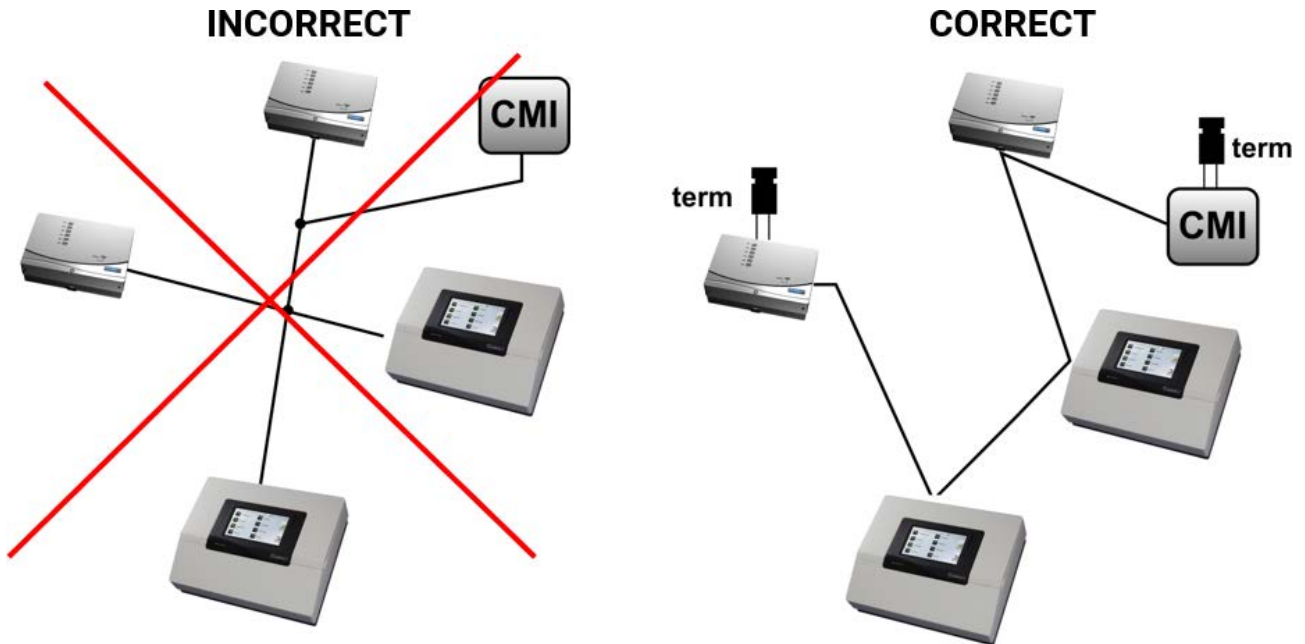

Example: Connection of three network nodes (NWN) with a 2x2-pole cable and **termination** of the terminal network nodes (network inside one building)

☐ terminated (termination resistor 120 Ohm)

☐ terminated open

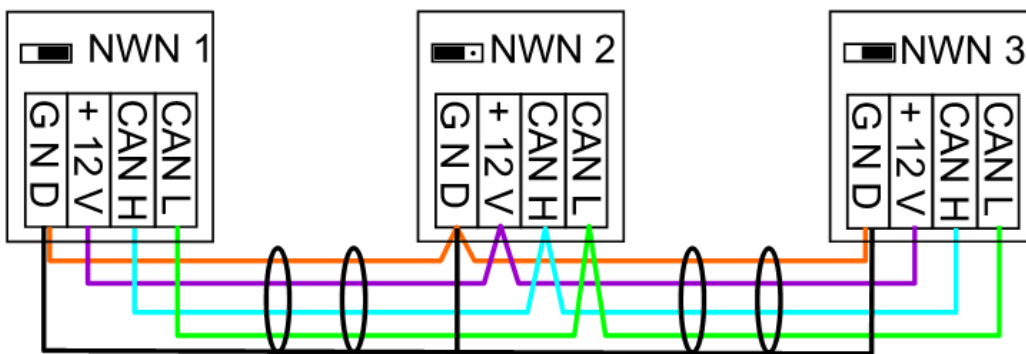

Each CAN network is to be provided with a 120 ohm BUS terminator at the first and last network subscriber (= **termination**). This is achieved with a plug-in jumper **at the back of the controller**. Each CAN network therefore always has two terminators (one at each end). Branch cables or a star topology are not permissible for CAN wiring.

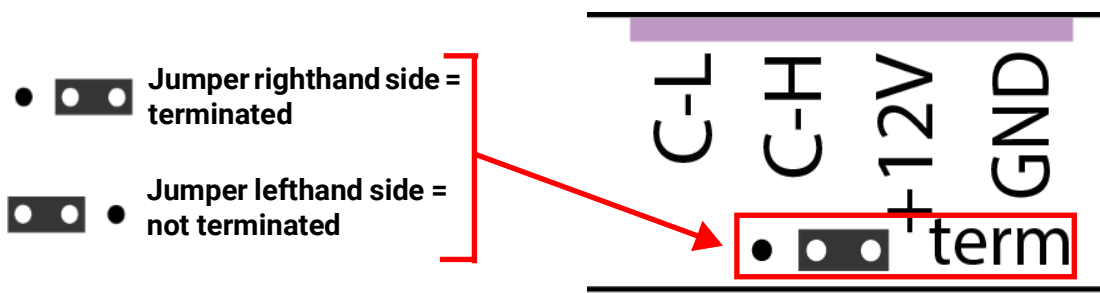

Branch cables

A CAN bus converter is used to provide reliable **long** branch cables. This means the branch cable is disconnected from the other CAN bus network and can be viewed as an independent CAN bus network.

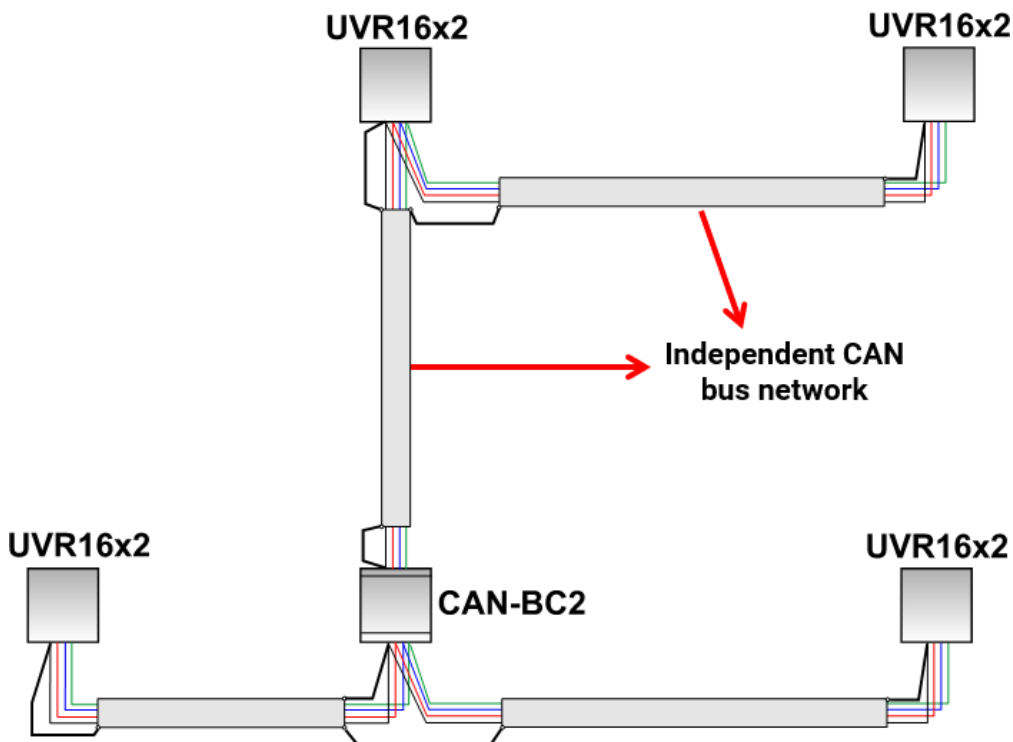

Trials at the factory have shown the following:

- 1) Branches with a star topology of up to 10 m will not impede transmission.
- 2) Up to a bus length of 250 m and a transfer rate of 50 kbit/s, data transfer works perfectly with a low number of CAN nodes and an inexpensive **J-Y(St)Y EIB KNX 2x2x0.8** KNX bus cable with a characteristic impedance of 75 to 90 ohm.
- 3) Up to a bus length of 150 m and with only a few nodes, the **CAT 5 24AWG** cable (typical Ethernet cable in PC networks) can be used.

Changing to cable types with different characteristic impedances is only permitted via signal separation through a CAN bus converter.

However, such networks do not comply with the recommended specification. Technische Alternative RT GmbH therefore cannot guarantee trouble-free operation if one of the three options listed above is applied.

Outputs

Terminal diagram, switching outputs

A6 = potential free output

The neutral conductor is looped inside the controller.

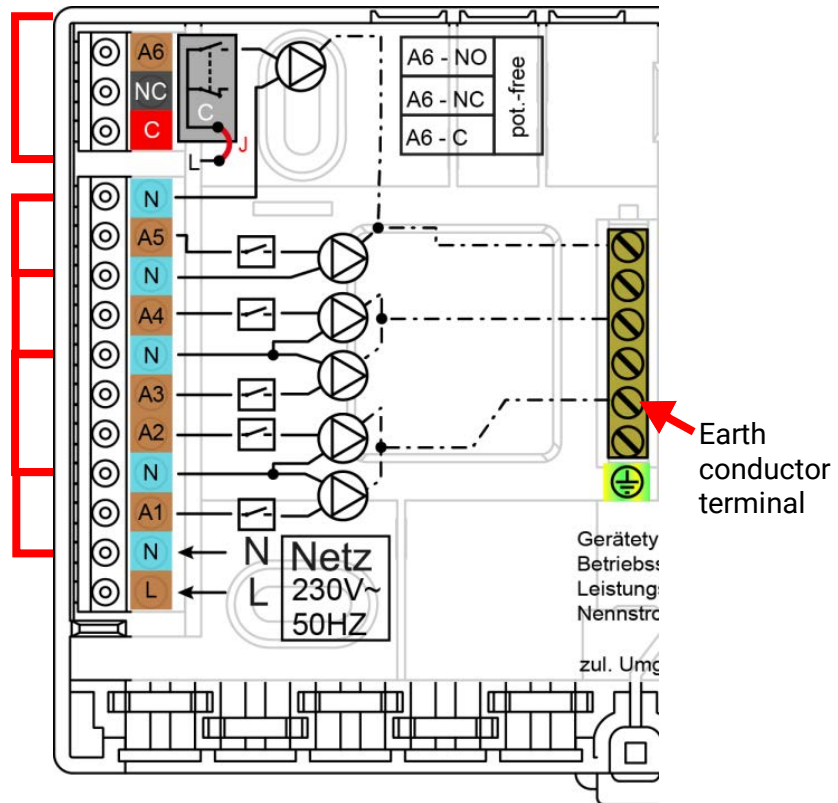

For the maximum current load of the outputs, see the **technical data**.

Output 6 with voltage applied

By unplugging jumper J, output A6 can be rendered potential-free.

View of module back:

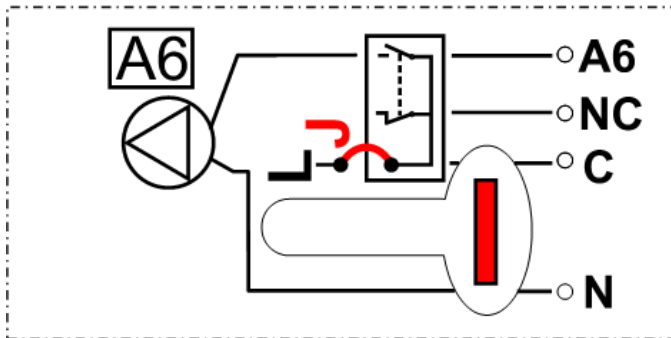

With jumper J plugged in, output 6 is **not** potential-free.

Example: Connecting a pump

- C (= L).... Phase conductor
- A6.... Normally open contact (N/O)
- NC.... Normally closed contact (N/C)

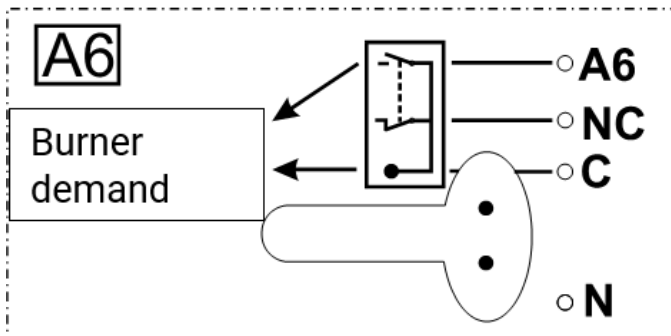

If the jumper is unplugged, output 6 is potential-free.

Example: Burner demand

- C.... Root C
- A6.... Normally open contact (N/O)
- NC.... Normally closed contact (N/C)

Terminal diagram for analogue outputs (0-10V / PWM)

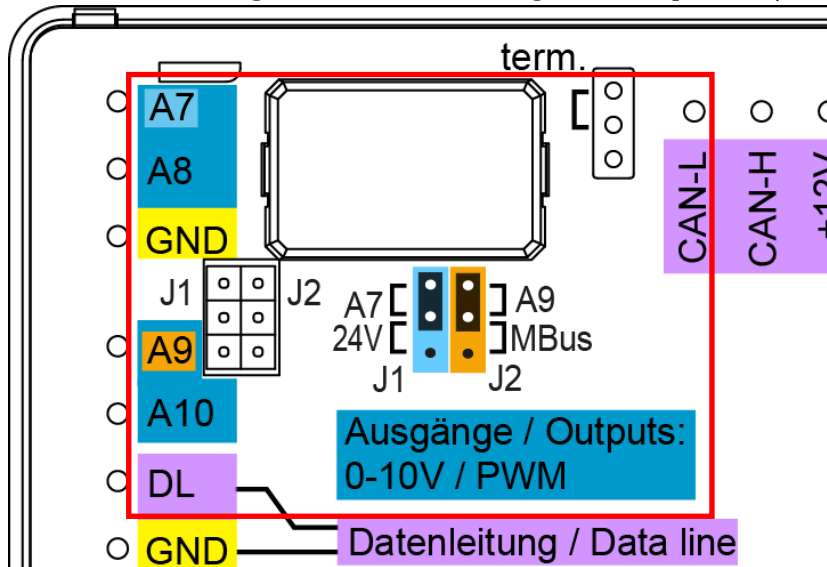

Connections **A7** – **A10** are the positive pole; the **GND** connection is the negative pole.

If programmed as a "switching output", a maximum of 2 **HIREL-230V** or **HIREL-PF** auxiliary relays can be connected.

24V supply

Output **A7** can be converted to supply external devices with **24 V=**. To do this, plug-in jumper **J1** must be moved from the upper to the lower position.



24V= supply active

The combined total load of all devices with 12 V and 24 V supply must not exceed **6 W**.

Connection for 24 V supply to terminal **A7** and **sensor earth** (GND).

Outputs **A8** and **A10** are the analogue outputs (0-10 V/PWM). **A9** also remains an analogue output if its M-Bus functionality is not used.

When using the 24 V supply, connections **A8** and **A10** become the **positive pole**; the GND connection is the **negative pole**.

If programmed as a "switching output", a maximum of 1 **HIREL-230V** or **HIREL-PF** auxiliary relay can be connected.

M-Bus

Output 9 can be converted for reading in M-Bus meters. To do this, plug-in jumper **J2** must be moved from the upper to the lower position.



M-Bus-interface active.

The connection is made at the terminals for **output 9** and **GND**.

The M-Bus has 2 wires: **M-Bus** (output 9) and **GND** (sensor earth). The power supply for reading data from M-Bus devices is provided by the UVR610.

Cables can be routed with a star topology or in series (from one device to the next). Ring topology is not permitted.

A two-wire screened cable is used as the M-Bus cable (e.g. telephone cable J-Y(ST)Y 2 x 2 x 0.8 mm). The maximum total cable length depends on the number of M-Bus devices connected and the cable cross-section.

Never run the M-Bus cable together with a CAN bus cable or DL bus cable in the same conduit.

Connection auxiliary relay HIREL-230V

Example: Connection to analogue outputs A7 and A8

Program outputs A7 and A8 as switching outputs.

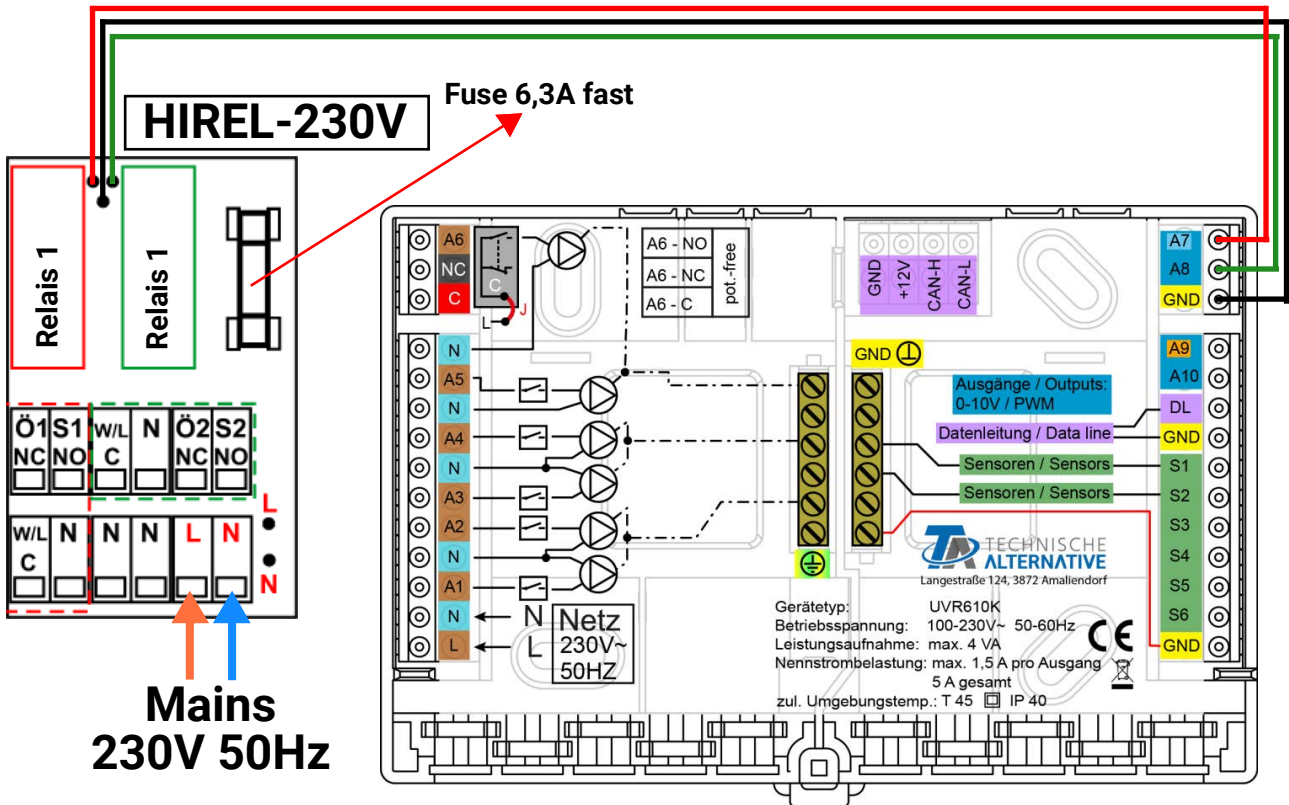

HIREL-230V wiring diagram

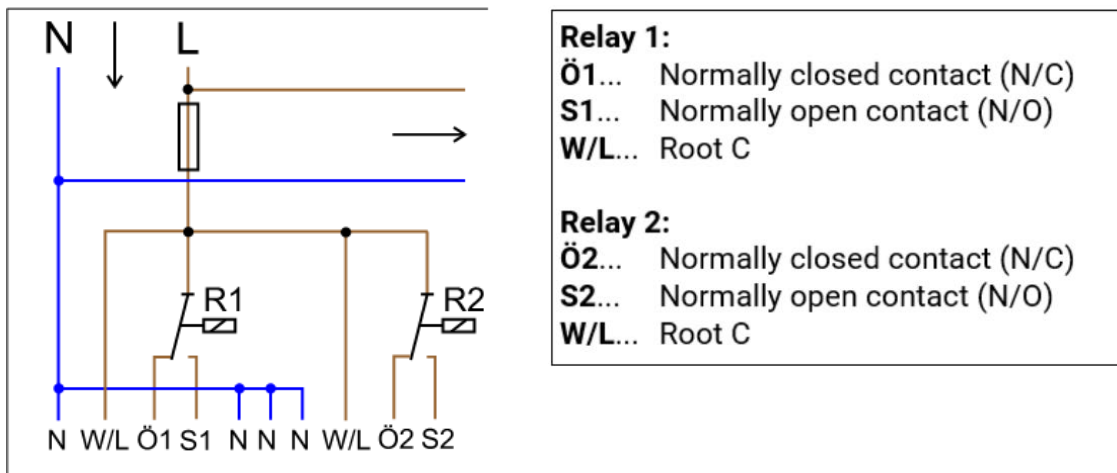

Both relay outputs are protected by the fuse on the relay module. Terminal "W" therefore corresponds to phase conductor "L".

If the fuse is removed, both outputs will be potential-free whilst remaining connected to one another via root "W".

The relay module can be connected to any two outputs between **A7** and **A10** if they have been programmed as **switching outputs**. If using on **A7** and/or **A9**, ensure that the associated jumper is in the upper position.

Technical data UVR610K-OD

All inputs	Temperature sensors type PT1000, KTY (2 k Ω /25 °C), KTY (1 k Ω / 25 °C), PT100, PT500, Ni1000, Ni1000TK5000 and room sensors RAS or RASPT, radiation sensor GBS01, thermocouple THEL-MV (without DL), humidity sensor RFS, rain sensor RES01, pulses max. 10 Hz (e.g. for VSG flow rate transducer), voltage up to 3.3 V DC , resistance (1-100 k Ω), and as a digital input (caution: potential-free)
Inputs 5-6	additionally voltage (0-10 V DC)
Outputs 1 - 5	Relay outputs, with N/O contacts
Output 6	Relay changeover contact – potential-free
Outputs 7 - 10	Analogue outputs 0-10 V (max. 20 mA) or PWM (10 V/1 kHz) in steps of 1000 at a time (=0.01 V or 0.1 % per step), or expansion option as switching outputs with additional relay modules
Max. breaking capacity	Relay outputs: 230 V / 3 A each
M-Bus	M-Bus input for up to 4 M-Bus meters (4 unit loads) supported protocol: EN1434-3
24V	Supply for external 24 V devices, max. 6 W in total, including the 12 V devices
Max. bus load (DL bus)	100%
CAN bus	Standard data rate 50 kbit/s, adjustable from 5 to 500 kbit/s
Differential temperatures	Equipped with separate start/stop differential
Threshold values	With separate start and stop differential or fixed hysteresis
Temperature measuring range	PT100, PT500, PT1000: -200 °C to +850 °C with a resolution of 0.1 K all other temperature sensors: -49.9 °C to +249.9 °C with a resolution of 0.1 K
Temperature accuracy	Typ. 0.4 K, max. \pm 1 K within a range of 0 - 100 °C for PT1000 sensors
Resistance accuracy	Max. 1,6% at 100k Ω (measured variable: Resistance, process variable: Resistance)
Voltage accuracy	typ. 1%, max. 3% of maximum input measuring range
Output 0-10V accuracy	max. -2% to +6%
Dimensions W x H x D	107 x 95 x 64 mm
Connection	100 – 230 V, 50 – 60 Hz, (joint 6.3 A (fast) fuse protection for outputs A1 – A5 and device) (fuse protection for output A6 only if voltage is applied; see „Outputs - Output 6 with voltage applied “ on page 16)
max. cable cross-section for power supply	2,5 mm ²
Power consumption	1.0 – 1.9 W, subject to the number of active switching outputs
IP rating	IP10
Protection rating	II – protective insulation <input type="checkbox"/>
Permissible ambient temperature	+5 to +45°C

Subject to technical modifications as well as typographical and printing errors. This manual is only valid for devices with the corresponding firmware version. Our products are subject to constant technical advancement and further development. We therefore reserve the right to make changes without prior notice.

© 2025

Tips on troubleshooting

Tech-support

We offer our customers free support in the event of questions or issues with our products.

Important: in order to answer your questions, we require the device serial number in every case.

If you are unable to locate the serial number, help with finding it is available on our homepage: <https://www.ta.co.at/haeufige-fragen/seriennummern/>

You can submit your request on our homepage using the following link: <https://www.ta.co.at/support/>.

As an alternative to the contact form, you can also call us during office hours on the following number: +43 (0)2862 53635

However, before contacting our support services, please try the following solutions:

No display points to a power failure. Therefore, initially check the fuse (6.3 A (fast)) that protects the device and the outputs (pumps, valves, etc.) from short circuits and from voltage surges in connection with the integrated surge protection. The glass tube fuse is located on the back of the module.

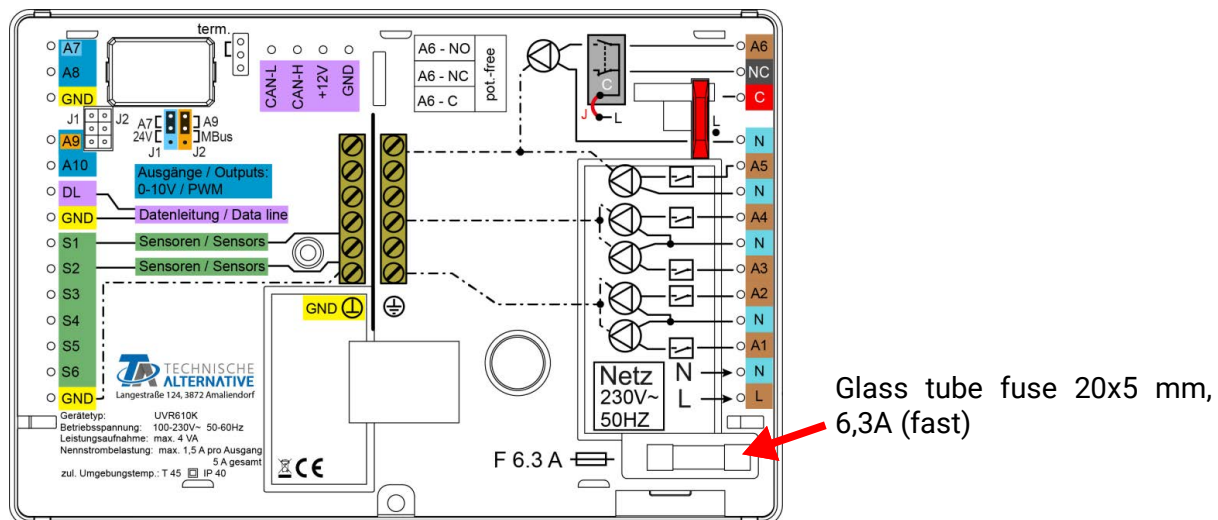

Realistic temperatures but faulty operation of the outputs indicates incorrect settings or termination. The device is in good order if it is possible to switch the outputs ON and OFF in manual mode; check all settings and termination.

- Do constant running and idle periods at the output result in a corresponding response? In other words, does this pump really run if the solar pump is activated manually, or does the heating circuit pump start instead of the solar pump?
- Are all of the sensors connected at the appropriate terminals (heat up the sensor using a lighter and check the temperature display)?

If you still cannot find any faults in the system, we recommend installing a datalogger (C.M.I.) and recording the temperature curves and switching states. If the DL BUS is used for data logging, enable "data output" in "DL settings".

Incorrect temperatures could be the result of the following:

- Values such as -9999.9 in the case of a sensor short circuit or 9999.9 in the case of a sensor lead break may not be the result of a material or termination error. Is the correct sensor type selected in the input menu (KTY, PT1000, RAS, GBS, etc.)?
- A sensor can also be checked without a tester simply by swapping the sensor that is probably faulty with one that works at the terminal strip and checking the temperature display. If the error is reproduced, the problem is the sensor. However, if the problem remains on the same input of the device, the fault is either due to the sensor type setting or the input itself is faulty (such as faulty surge protection).

Table of resistances of various sensor types

Temp.	[°C]	0	10	20	25	30	40	50	60	70	80	90	100
PT1000	[Ω]	1000	1039	1078	1097	1117	1115	1194	1232	1271	1309	1347	1385
KTY (2kΩ)	[Ω]	1630	1772	1922	2000	2080	2245	2417	2597	2785	2980	3182	3392
KTY (1kΩ)	[Ω]	815	886	961	1000	1040	1122	1209	1299	1392	1490	1591	1696
PT100	[Ω]	100	104	108	110	112	116	119	123	127	131	135	139
PT500	[Ω]	500	520	539	549	558	578	597	616	635	654	674	693
Ni1000	[Ω]	1000	1056	1112	1141	1171	1230	1291	1353	1417	1483	1549	1618
Ni1000 TK5000	[Ω]	1000	1045	1091	1114	1138	1186	1235	1285	1337	1390	1444	1500

If the sensor is faulty, note the sensor type when replacing. While it is possible to use a different type of sensor, the parameters for that input also have to be set to suit the type of sensor used.

The current standard type used by Technische Alternative is PT1000.

KTY (2 kΩ) was the standard type until 2010/2011.

Manual switching of an output not possible:

- Ensure that output 6 is generally potential-free and therefore does not carry live voltage. Auxiliary relay outputs may also be potential-free. It is thus only possible to directly switch a 230 V consumer when the appropriate wiring has been implemented.
- If it is not possible to switch the output ON or OFF in manual mode, a message may be active at that moment which switches the corresponding output dominantly ON or OFF (red frame around the output symbol; indication of the message in the upper status bar). Subject to programming and user status, manual mode is not possible in this case.

Troubleshooting – hardware

In a clear case of a hardware fault, please return the device to your retailer or the manufacturer for repair. In this case it is essential to include a fault description with the device (simply stating "the device does not work, please repair" is insufficient). Processing is accelerated if an RMA number is requested via our homepage www.ta.co.at. The defect must be clarified with our technical support beforehand.

Troubleshooting – programming

The manufacturer can assist you in troubleshooting if you have the correct documentation and sufficient data to hand. The following are indispensable for this:

- a hydraulic scheme via fax or email (WMF, JPG),
- the complete program via TAPPS file or at least the function data (*.dat file) by email,
- operating system version and controller serial number,
- all existing log files or at least the (temperature) values of the inputs at the time the system malfunctioned,
- telephone contact for describing the problem – in most cases a written fault description is not enough.

Troubleshooting in the CAN network

To isolate the error we recommend shutting down part of the network and monitoring when the error disappears.

General tests:

- Node numbers – no node number must be assigned twice
- Power supply to BUS subscribers (if necessary use the CAN-NT power supply unit)
- Setting of the Baud rate (even when using the CAN BUS converter CAN-BC2)

Wiring test:

All nodes must be switched off for this test.

- Resistance across CAN-H and CAN-L
 - If this is in excess of 70 Ω , it indicates incorrect termination.
 - If the resistance is below 60 Ω , look for too many terminations or short circuits between cables/leads.
- Check for short circuits across GND or screen and the signal cables.
- Check for earth loops – for this the screen is undone at each node and the current tested. If there is a current flow, an earth loop has been created by an unwanted earth connection.

Information on the ECO-design Directive 2009/125/EG

Product	Class ^{1,2}	Energy efficiency ³	Standby max. [W]	Power consumption typ. [W] ⁴	Max. power consumption [W] ⁴
UVR610 ⁵	max. 8	max. 5	1,0	0,80 / 1,55	1,0 / 1,9

¹ Definitions according to Official Journal of the European Union C 207 dated 03/07/2014

² The classification applied is based on optimum utilisation and correct application of the products. The actual applicable class may differ from the classification applied.

³ Contribution of the temperature controller to seasonal central heating efficiency in percent, rounded to one decimal place

⁴ No output active = standby / all outputs and display active

⁵ The class is defined on the basis of the programming of the heating circuit controller, in accordance with the Ecodesign Directive.

Subject to technical modifications as well as typographical and printing errors. This manual is only valid for devices with the corresponding firmware version. Our products are subject to constant technical advancement and further development. We therefore reserve the right to make changes without prior notice.

© 2025

EU Declaration of conformity

Document-No. / Date: TA19003 / 19.06.2019
Company / Manufacturer: Technische Alternative RT GmbH
Address: A-3872 Amaliendorf, Langestraße 124

This declaration of conformity is issued under the sole responsibility of the manufacturer.

Product name: UVR610S, UVR610S-OD, UVR610S-OD-MODB, UVR610K, UVR610K-OD
Product brand: Technische Alternative RT GmbH
Product description: Freely programmable universal controller

The object of the declaration described above is in conformity with Directives:

2014/35/EU Low voltage standard
2014/30/EU (11/09/2018) Electromagnetic compatibility
2011/65/EU (01/10/2022) RoHS Restriction of the use of certain hazardous substances
2009/125/EU (04/12/2012) Eco-design directive

Employed standards:

EN 60730-1: 2011	Automatic electrical controls for household and similar use – Part 1: General requirements
EN 61000-6-3: 2007 + A1: 2011 + AC2012	Electromagnetic compatibility (EMC) - Part 6-3: Generic standards - Emission standard for residential, commercial and light-industrial environments
EN 61000-6-2: 2005 + AC2005	Electromagnetic compatibility (EMC) - Part 6-2: Generic standards - Immunity for industrial environments
EN 50581: 2012	Technical documentation for the assessment of electrical and electronic products with respect to the restriction of hazardous substances

Position of CE - label: On packaging, manual and type label



Issuer: Technische Alternative RT GmbH
A-3872 Amaliendorf, Langestraße 124

This declaration is submitted by

A handwritten signature in black ink that reads "Schneider Andreas". The signature is written in a cursive style.

Dipl.-Ing. Andreas Schneider, General manager,
19.06.2019

This declaration certifies the agreement with the named standards, contains however no warranty of characteristics.

The security advices of included product documents are to be considered.

Warranty conditions

Note: The following warranty conditions do not in any way limit the legal right to warranty, but rather expand your rights as a consumer.

1. The company Technische Alternative RT GmbH provides a one-year warranty from the date of purchase for all the devices and parts which it sells. Defects must be reported immediately upon detection and within the guarantee period. Technical support knows the correct solution for nearly all problems. In this respect, contacting us immediately will help to avoid unnecessary expense or effort in troubleshooting.
2. The warranty includes the free of charge repair (but not the cost of on site troubleshooting, removal, refitting and shipping) of operational and material defects which impair operation. In the event that a repair is not, for reasons of cost, worthwhile according to the assessment of the Technische Alternative company, the goods will be replaced.
3. Not included is damage resulting from the effects of over-voltage or abnormal ambient conditions. Likewise, no warranty liability can be accepted if the device defect is due to: transport damage for which we are not responsible, incorrect installation and assembly, incorrect use, disregard of operating and installation instructions or incorrect maintenance.
4. The warranty claim will expire, if repairs or actions are carried out by persons who are not authorised to do so or have not been so authorised by us or if our devices are operated with spare, supplementary or accessory parts which are not considered to be original parts.
5. The defective parts must be sent to our factory with an enclosed copy of the proof of purchase and a precise description of the defect. Processing is accelerated if an RMA number is applied for via our home page www.ta.co.at. A prior clarification of the defect with our technical support is necessary.
6. Services provided under warranty result neither in an extension of the warranty period nor in a resetting of the warranty period. The warranty period for fitted parts ends with the warranty period of the whole device.
7. Extended or other claims, especially those for compensation for damage other than to the device itself are, insofar as a liability is not legally required, excluded.

Legal notice

These assembly and operating instructions are protected by copyright.

Use outside the copyright requires the consent of the company Technische Alternative RT GmbH.

This applies in particular to reproductions, translations and electronic media.

Technische Alternative RT GmbH

A-3872 Amaliendorf, Langestraße 124

Tel.: +43 (0)2862 53635

E-Mail: mail@ta.co.at

Fax +43 (0)2862 53635 7

-- www.ta.co.at --



©2025