

# FWR 21

Version 1.1-1 EN

## Fresh water controller



Operation  
Installation instructions

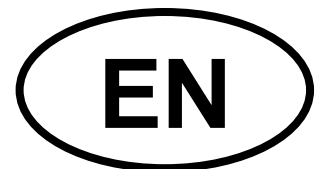

TECHNISCHE  
ALTERNATIVE



# Table of contents

Safety requirements.....	4
Maintenance .....	4
System schematic.....	5
Speed control.....	6
Manual / automatic switchover.....	6
Terminal assignments.....	7
Selection switch control method .....	8
Technical data .....	8

## Safety requirements



**All installation and wiring work on the controller must only be carried out in a zero-volts state.**

**The opening, connection and commissioning of the device may only be carried out by competent personnel. In so doing, all local security requirements must be adhered to.**

The device corresponds to the latest state of the art and fulfils all necessary safety conditions. It may only be used or deployed in accordance with the technical data and the safety conditions and rules listed below. When using the device, the legal and safety regulations apposite to the particular use are also to be observed.

- ▶ The device must only be installed in a dry interior room.
- ▶ It must be possible to isolate the controller from the mains using an all-pole isolating device (plug/socket or double pole isolator).
- ▶ Before starting installation or wiring work, the controller must be completely isolated from the mains voltage and protected against being switched back on. Never interchange the safety extra-low voltage connections (sensor connections) with the 230V connections. Destructive and life-threatening voltages at the device and the connected sensors may occur.
- ▶ For safety reasons, the system should only be left in manual mode when testing. In this operating mode, no maximum temperatures or sensor functions are monitored.
- ▶ Safe operation is no longer possible if the controller or connected equipment exhibits visual damage, no longer functions or has been stored for a lengthy period of time under unsuitable conditions. If this is the case, place the controller and equipment out of service and secure against unintentional use.

## Maintenance

If used properly, the system does not require maintenance.

As the components relevant to accuracy are not subjected to loads if used properly, long-term deviation is very low. The unit thus cannot be adjusted.

The construction characteristics of the unit must not be changed for repairs. Spare parts must correspond to the original parts and be used as intended.

## System schematic

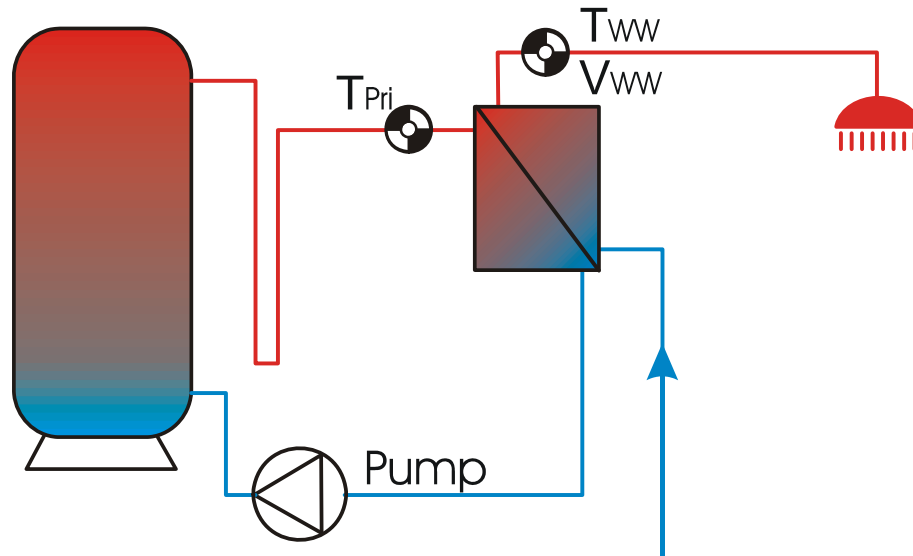

$T_{Pri}$	Primary-temperature sensor, sensor type: fast response clip-on sensor SAF
$V_{ww}$	Volume flow sensor hot water, sensor type: VFS 2-40
$T_{ww}$	Temperature sensor hot water: Temperature value is transferred from the VFS to the controller

The pump is speed-controlled dependent on the temperature measurement values from the sensors, as soon as a minimum flow is detected at the volume flow encoder. Using the speed control, the heat exchanger outlet temperature is maintained at the set hot water target temperature using the hot water temperature sensor  $T_{ww}$ . The supplied fast response clip-on sensor must always be used as the primary sensor,  $T_{Pri}$ .

If the tank is operated with a temperature higher than  $75^{\circ}\text{C}$ , it is recommended that a pre-mixer is used as it limits the primary temperature to  $75^{\circ}\text{C}$ . The difference between the primary and hot water temperatures should always be greater than 20 K.

## Speed control

On the inside of the controller there are a selection switch and a jumper, with which different control methods of the speed control can be set:

1. **Wave packet control** Variant 1 (PuT.1 = Pump type 1), optimised for pump types WILO Star RS25/6 and RSG 25/7
2. **Wave packet control** Variant 2 (PuT.2 = Pump type 2), optimised for pump types Grundfos UPS 25-60 and UPS 25-80

Wave packet control is not suitable for electronic or high efficiency pumps.

3. Control of an electronic pump with **inverse 0-10V or PWM control input** (full speed at 0 V or 0%, or stationary at 10 V or 100%.)
4. Control of an electronic pump with **normal 0-10V or PWM control input** (full speed at 10 V or 100 %, or stationary at 0 V or 0 %.)

Switching between 0-10V and PWM actuation takes place using jumpers.

**Important note:** The control of high efficiency pumps with a 0-10 V or PWM control input is currently not recommended as these pumps in their current state of development respond too slowly to signal changes. Therefore with these pumps the control behaviour is not satisfactory.

## Manual / automatic switchover

On the front side of the controller there is a sliding switch with the functions OFF, automatic (= normal setting) and ON (= full speed).

An LED control lamp indicates that the pump is operating. If speed control by means of wave packet control is activated, then the LED flashes according to the speed stage.

# Terminal assignments

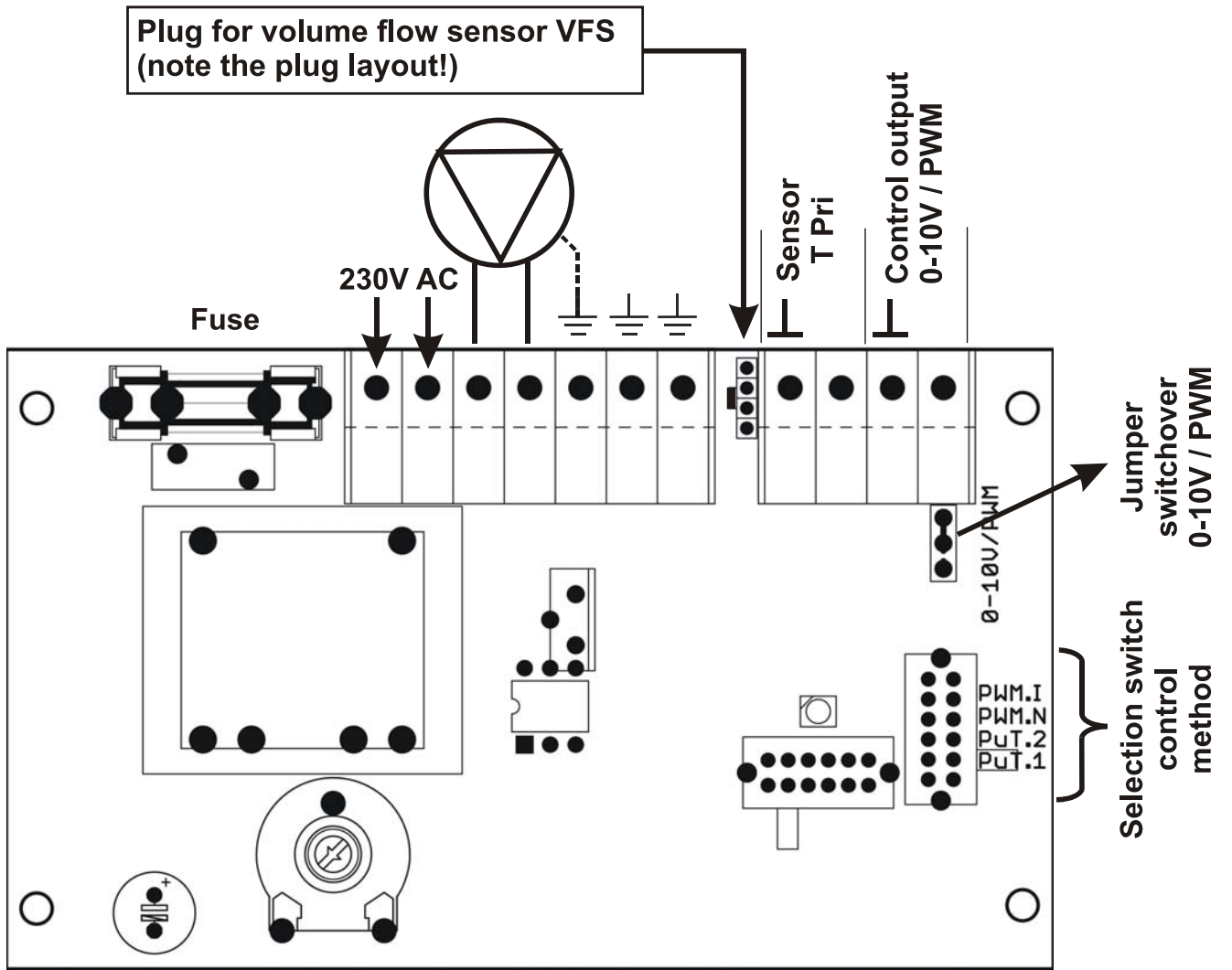

## Selection switch control method

Switch position	Control method
<b>PWM.I</b>	Control of an electronic pump with <b>inverse</b> 0-10V or PWM control input
<b>PWM.N</b>	Control of an electronic pump with <b>normal</b> 0-10V or PWM control input
<b>PuT.2</b>	<b>Wave packet control</b> variant 2
<b>PuT.1</b>	<b>Wave packet control</b> variant 1

When plugging in the plug for the volume flow sensor VFS ensure the correct arrangement of the plug in accordance with the drawing.

⊥ = sensor ground

## Technical data

Hot water temperature:	adjustable from 35 - 65°C
Output:	230V~/ max. 200VA
Power consumption:	max. 2 W
Fuse:	3.15 A fast-acting
Dimensions (W/H/D):	127 x 76 x 51 mm
Length of the cable to the VFS	500 mm
Allowed ambient temperature:	0 to 45° C
Protection class:	IP40

We reserve the right to make technical changes.

© 2012



# TECHNISCHE ALTERNATIVE

ELEKTRONISCHE STEUERUNGSGERÄTEGESELLSCHAFT M. B. H.

A-3872 Amaliendorf, Langestraße 124

## EC- DECLARATION OF CONFORMITY

*Document- Nr. / Date* TA10016 / 03.09.2010  
*Company / Manufacturer:* Technische Alternative  
elektronische SteuerungsgerätegesmbH.  
*Address:* A- 3872 Amaliendorf, Langestraße 124  
*Product:* FWR21  
*The stated above product complies with the following essential requirements:*  
*EU requirements:* 2006/95/EG Low voltage standard  
2004/108/EG Electromagnetic compatibility

### *Employed standards:*

EN 60730-1:2009 08 01 Automatic electrical controls for household and similar use -  
Part 1: General requirements  
EN 61000-6-3:2007 11 01 Electromagnetic compatibility (EMC) - Part 6-3: Generic  
standards - Emission standard for residential, commercial  
and light-industrial environments  
EN 61000-6-2:2006 05 01 Electromagnetic compatibility (EMC) - Part 6-2: Generic  
standards - Immunity for industrial environments

*Position of CE - label:* On packaging, manual and type label



*Issuer:* Technische Alternative  
elektronische SteuerungsgerätegesmbH.  
A- 3872 Amaliendorf, Langestraße 124

*This declaration is submitted by:*

*General management*

This declaration certifies the agreement with the named standards, contains however  
no warranty of characteristics.  
The security advices of included product documents are to be considered.

UIDNr.: ATU 17986204, Firmenbuch-Nr.: FN37578m, DVR-Nr.:1011553, ARA-Lizenz-Nr.:1996

Telefon ++43(0)2862/53635 Fax ++43(0)2862/53635-7 E-mail: mail@ta.co.at <http://www.ta.co.at>





## **Guarantee conditions**

**Note:** The following guarantee conditions do not in any way limit the legal right to a guarantee, rather expand your rights as a consumer.

1. The company Technische Alternative elektronische Steuerungsgesellschaft m. b. H. provides a two-year guarantee from the date of purchase by the end consumer for all the devices and parts which it sells. Defects must be reported immediately upon detection and within the guarantee period. Technical support knows the correct solution for nearly all problems. In this respect, contacting us immediately will help to avoid unnecessary expense or effort in troubleshooting.
2. The guarantee includes the free of charge repair (but not the cost of on site fault-finding, removal, refitting and shipping) of operational and material defects which impair operation. In the event that a repair is not, for reasons of cost, worthwhile according to the assessment of Technische Alternative, the goods will be replaced.
3. Not included is damage resulting from the effects of overvoltage or abnormal ambient conditions. Likewise, no guarantee liability can be accepted if the device defect is due to: transport damage for which we are not responsible, incorrect installation and assembly, incorrect use, non-observance of operating and installation instructions or incorrect maintenance.
4. The guarantee claim will expire if repairs or actions are carried out by persons who are not authorised to do so or have not been so authorised by us or if our devices are operated with spare, supplementary or accessory parts which are not considered to be original parts.
5. The defective parts must be sent to our factory with an enclosed copy of the proof of purchase and a precise description of the defect. Processing is accelerated if an RMA number is applied for via our home page [www.ta.co.at](http://www.ta.co.at). A prior clarification of the defect with our technical support is necessary.
6. Services provided under guarantee result neither in an extension of the guarantee period nor in a resetting of the guarantee period. The guarantee period for fitted parts ends with the guarantee period of the whole device.
7. Extended or other claims, especially those for compensation for damage other than to the device itself are, insofar as a liability is not legally required, excluded.

### **TECHNISCHE ALTERNATIVE**

elektronische Steuerungsgerätegesellschaft m. b. H.

A-3872 Amaliendorf Langestraße 124

Tel ++43 (0)2862 53635

Fax ++43 (0)2862 53635 7

E-Mail: [mail@ta.co.at](mailto:mail@ta.co.at)

--- [www.ta.co.at](http://www.ta.co.at) ---

© 2012

